



# INSTALL INSTRUCTIONS FOR 75-5150/75-5150D



PRINT

## BEFORE YOU START

**VEHICLE FITMENT:** 2021-2024 6.2L V8, Ram, 1500 TRX

**DEVICE NAME:** COLD AIR INTAKE

## REQUIRED TOOLS

- T27 Torx Bit and Driver
- 5/16" Nut Driver or Socket and Driver
- 1/4" Nut Driver or Socket and Driver
- 2x 10mm sockets + Socket Wrench, Driver or wrench
- 13mm socket or Driver
- Panel Popper
- Flathead Screwdriver
- Phillips Head Screwdriver
- Knife, Cutting tool

Please read the entire product guide before proceeding

- Ensure all parts are present.
- If you are missing any parts, please call or text us at (909)-675-1313
- Do not work on your vehicle while the underbody components are hot.
- Make sure the vehicle is in park or the parking brake is set if you plan on working on the ground. If working on a lift, make sure the vehicle is lifted safely and securely.
- This intake kit may not fit with the following aftermarket parts installed: Body Lift or Lowering Kit, Custom Hood Intercooler, or Turbo upgrades.

ENTER TO WIN



Hi. Need any help?



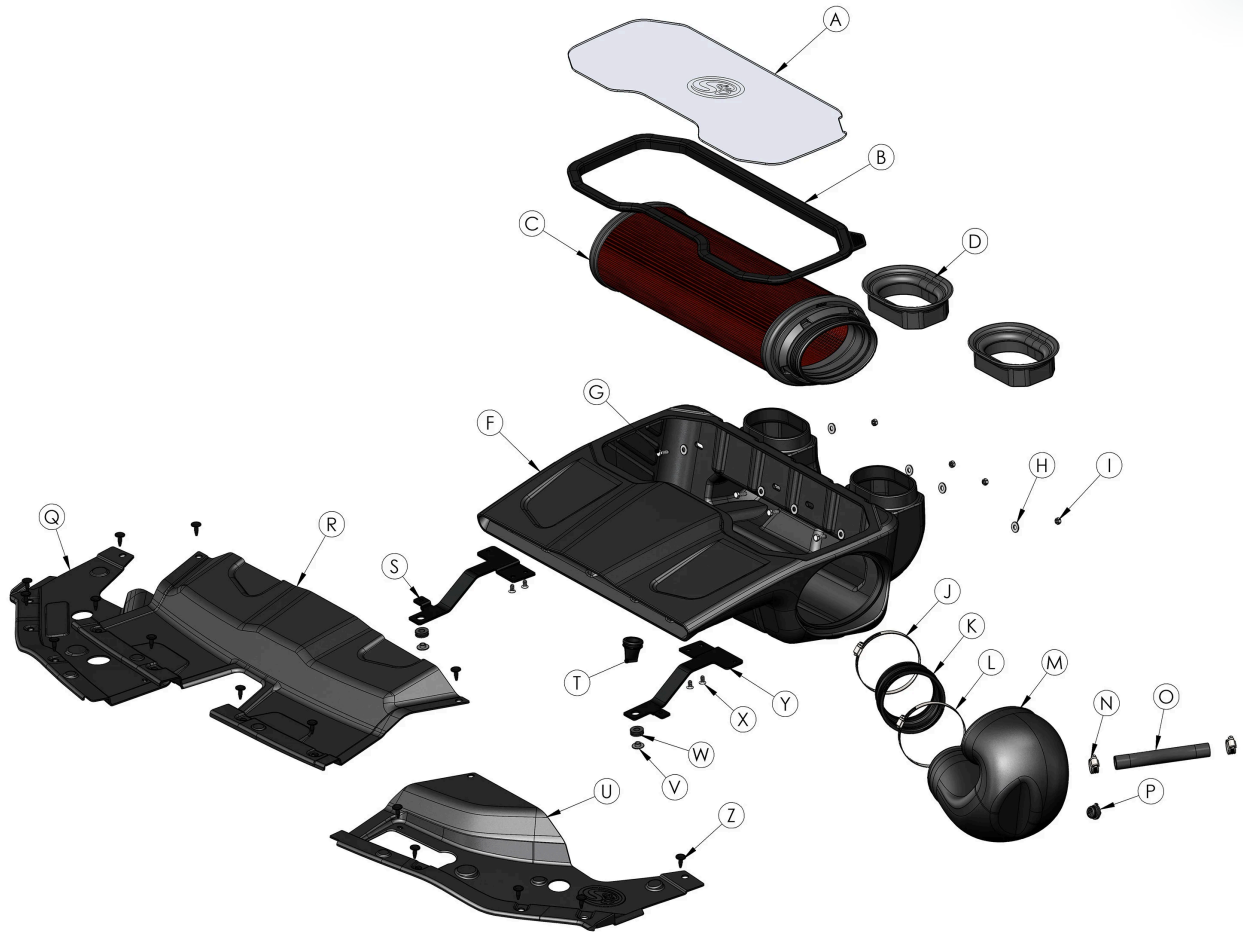

ITEM	QTY.	DESCRIPTION	PART NUMBER
A	1	Polycarbonate Lid	Ai2678-00
B	1	Snap-in Lid seal	Ai2668C-00
C	1	Kit Filter	KF-1086 / KF-1086D
D	2	Scoop Seal	Ai2669C-00
E	1	#104 Hose Clamp	AG1012-00
F	1	Air Box	AL1395B-00
G	4	Hex Head Screw M6	Ai1257-00
H	8	M6 Washer	Ai1755-00
I	4	M6 Locknut	Ai1090-00
J	1	#64 Hoseclamp	AG1018-00
K	1	Coupler	Ai1542C-01
L	1	#72 Hoseclamp	AG1009-00
M	1	Tube	AL1395-00
N	2	#12 Hoseclamp	AG1030-00
O	1	Wrapped CCV hose	Ai2693-00
P	1	IAT Sensor Grommet	Ai1948C-00
Q	1	Passengers Side Radiator Closeout	Ai2672-00
R	1	Front Radiator Closeout	Ai2673-00
S	1	Passengers Side Bracket	Ai2677-00
T	1	One way valve	Ai2275C-00
U	1	Drivers Side Radiator Closeout	Ai2674-00
V	2	Shoulder Washer	OEM
W	2	Grommet	OEM
X	4	1/4"-20 X 1/2" Torx Flat Head Screw	Ai2692-00
Y	1	Drivers Side Bracket	Ai2676-00
Z	14	Nylon Reusable Rivet	Ai1763-00

## STEP 1

With the engine off and cooled down open the hood to begin the installation by pulling the engine cover firmly away from the stock air cleaner system.



## STEP 2

Remove the 14 reusable plastic rivets securing the radiator cover using a flathead screwdriver or panel popper. Remove the radiator cover from the engine and set it to the side. Set the rivets to the side to be used later.



## STEP 3

Using a T27 Torx bit or 10mm socket, unthread the 2 front screws securing the front of

the airbox. Set the screws to the side to be reused later in the installation.

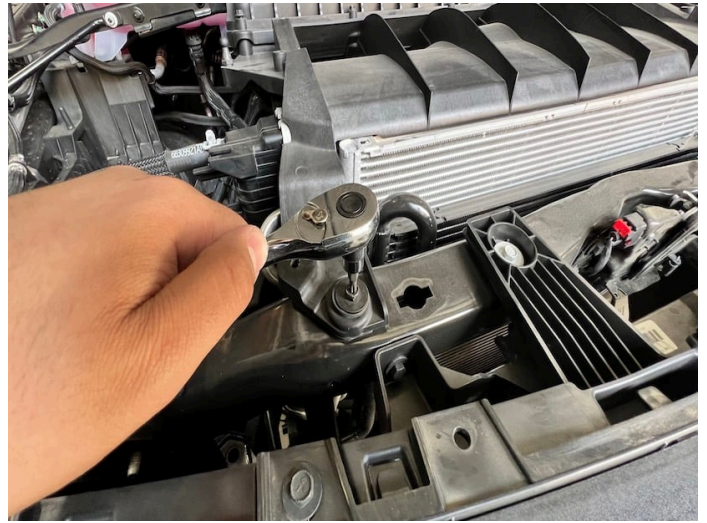

## STEP 4

Begin removing the airbox support bracket by using a 10mm and 13mm socket at the six locations at both passenger and driver's fender sides. Collect those 6 bolts to be reused later.



## STEP 5

Undo the hose clamp at the stock airbox to the intake tube connection using a 5/16" driver or flat head screwdriver.

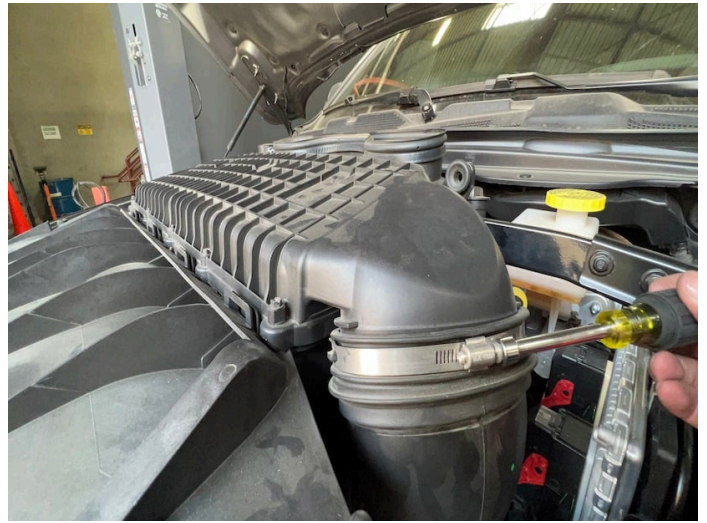

## STEP 6

Pry up the stock airbox away from the tube and pull the airbox and support bracket assembly out of the vehicle. Set the assembly to the side.



## STEP 7

At the tube, unplug the IAT sensor harness from the stock sensor connection.

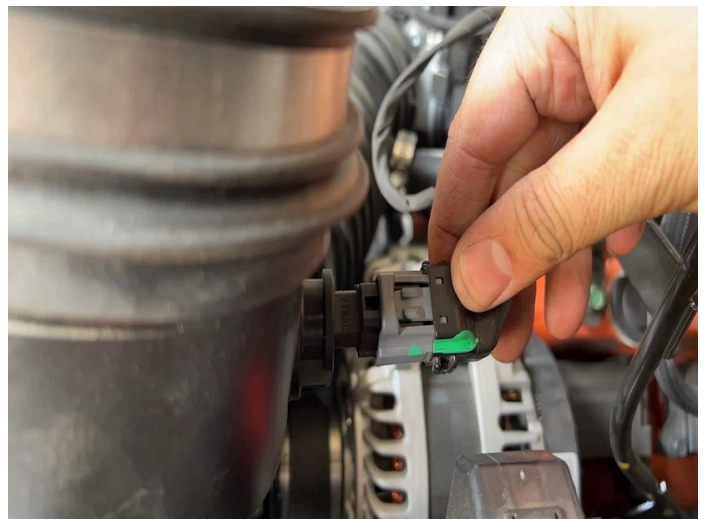

## STEP 8

Using a knife or cutting tool, score the nylon shrink-wrapped hose at the solenoid connection. Be careful to only cut deep enough to be able to split the hose and to not cut into the plastic breather underneath. Once cut, pry the hose away from the breather.

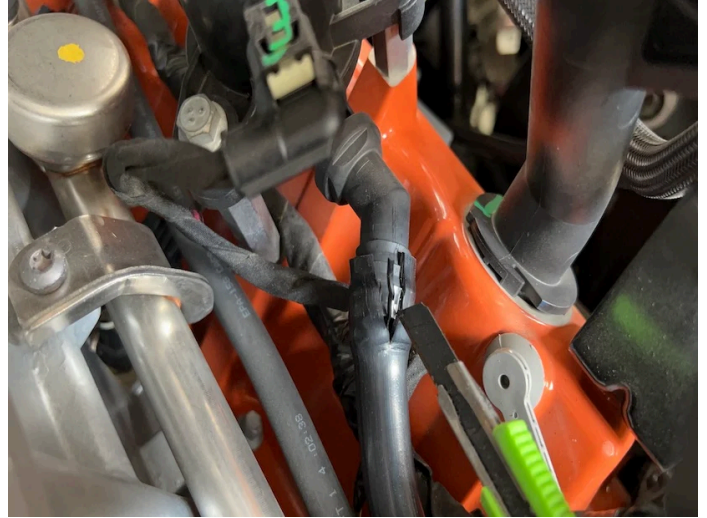

## STEP 9

Loosen the hose clamp at the throttle body and disconnect the intake tube. Pull the tube assembly out of the engine compartment and set it aside.

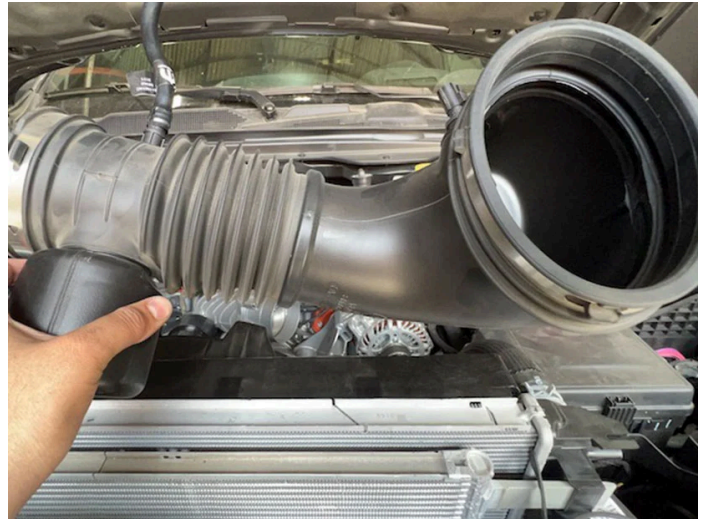

## STEP 10

Remove the hardware securing the airbox to gain access to the bracket

mounting hardware using a long reach flathead or Phillips head screwdriver. 10 locations in total.



## STEP 11

Remove the 4 airbox bracket mounting screws using a T27 Torx bit and driver. Separate the stock airbox from the mounting bracket support. Set the support bracket to the side to be reused.



## STEP 12

Using a flathead screwdriver pry off the grommets and shoulder spacers from the front-most area of the stock airbox.



### STEP 13

Transfer the shoulder spacers and grommets to the S&B mounting brackets in the orientation as shown with the flat of the shoulder bushing away from the screw and washer mounting area.



### STEP 14

Install the S&B IAT Sensor grommet onto the S&B intake tube. Transfer the IAT sensor from the OEM tube into the S&B tube as shown. The locking tab should rotate over the ramp and lock into

position, use the turn arrow for indication.



## STEP 15

Install the CCV vent silicone-wrapped hose onto the S&B tube at the breather connection using 2 #12 hose clamps.



## STEP 16

Install the coupler and hose clamps onto the S&B Tube.



## STEP 17

Install the tube into the vehicle by pushing the coupler over the throttle body. Push the CCV tube over the CCV connection end, and rotate into position as needed. Be aware to allow the fuse box clearance to be removed easily for future access. Tighten the hose clamps.



## STWP 18

Reconnect the IAT wire harness to the IAT Sensor on the S&B Tube.



## STEP 19

Attach the 2 airbox mounting brackets onto the front of the S&B Airbox using the

supplied 1/4 -20 Torx flat head screws and a T27 Torx Bit.



## STEP 19A

The right (passenger) side bracket has an additional bend.

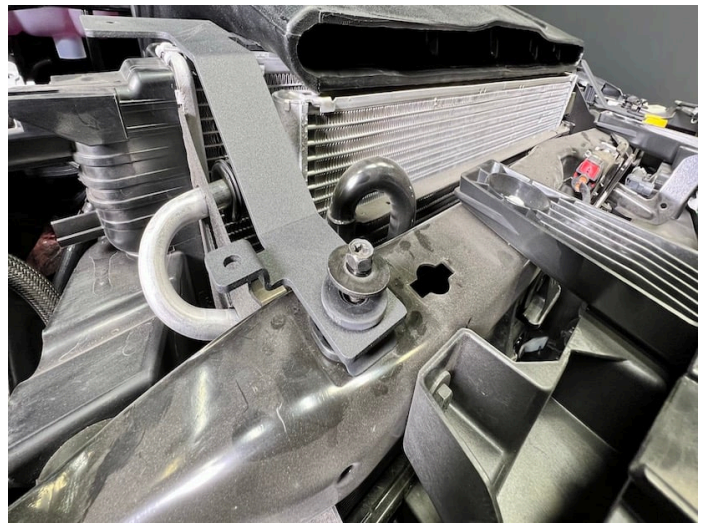

## STEP 20

Install the silicone one-way valve onto the bottom of the airbox



## STEP 21

Attach the stock airbox support bracket to the back of the S&B Airbox using the provided M6 washers nuts and screws, and a 10mm socket and wrench or 2 10mm sockets. Run the screws through the S&B airbox lining up with the holes in the bracket. Do not tighten completely.



## STEP 22

Install the silicone hood scoop seals onto the airbox.



## STEP 23

Install the S&B snap-in filter into the airbox. For easier installation, fold the filter

flange inward towards the inside of the filter. Once the filter is in the airbox push the snap in a portion of the flange through the opening of the airbox. After the filter is snapped into place, fold the flange to its original position.



## STEP 24

Install the hose clamp over the filter flange loosely.



## STEP 25

Install the airbox, support bracket, and filter assembly into the engine compartment. Push the intake tube into the filter flange and verify the S&B front airbox support brackets and the stock airbox support bracket align with their mounting holes.

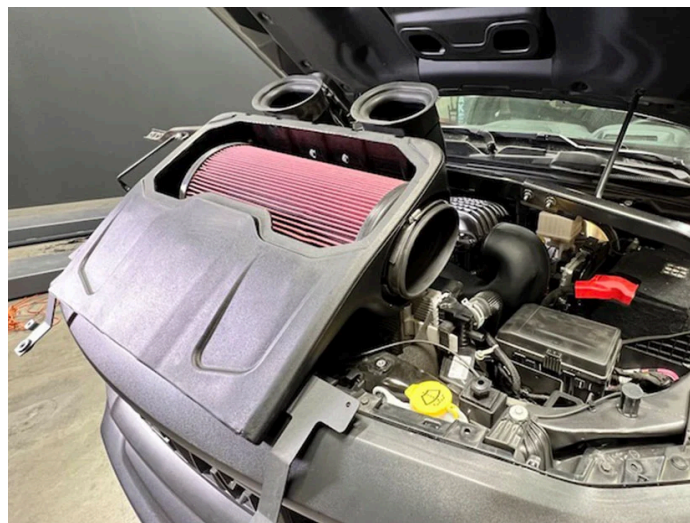

## STEP 26

Tighten the air filter onto the S&B intake tube with the hose clamp from Step 24.



## STEP 27

Reinstall the airbox support bracket hardware in their positions from Step 4 using 10mm and 13mm sockets.

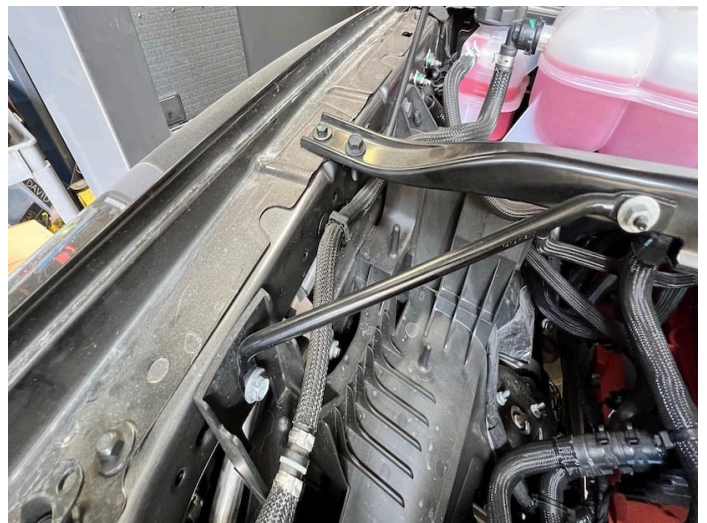

## STEP 28

Install the front S&B airbox bracket hardware using a T27 Torx bit and driver or 10mm socket. After all support brackets are secured, tighten

the 4 M6 screws and nuts from Step 21.



## STEP 29

Remove the protective wrapping of the polycarbonate lid. Install the snap-in silicone lid seal around the polycarbonate lid. Install the snap-in lid assembly onto the airbox. Slide into the box as shown and use pressure around the perimeter to install the Snap-in lid.



## STEP 30

Place the driver's side and passenger's radiator closeout into position over the intake

and engine. Place the front cover over those two closeouts. Install the included plastic reusable rivets into the S&B radiator cover hole positions.



### STEP 30A

Use the stock rivets at the two highest points on the cover.



### STEP 30B

Use the S&B supplied rivets at the 2 locations nearest to the S&B airbox.



## STEP 31

Inspect your installation. Make sure the kit is properly positioned and all fasteners and hose clamps are secured. Keep all stock parts in the event you would ever need to reinstall the stock intake assembly. If you are an installer, give the owner the QR code for the Installation Instructions so that he/she is aware of the Maintenance and Operation procedures are given at the beginning of the Instructions. The installation is now complete.



## CARB EO LABEL

Please affix the included CARB-approved EO label in an area under the hood, or the underside of the vehicle's hood near the radiator shroud, or the underside of the vehicle's hood near the S&B product.



### Vehicle **CARB EO** Label Placement

**Sample Label:**

	
PERFORMANCE FILTERS AND INTAKES	
Cotton (Cleanable) Dry (Disposable)	
Cold Air Intake System Part #:	75-5150 75-5150D
CARB EO #:	D-590-XX
S&B Filters Inc., Fontana, CA, (800) 358-2639	

**Locations:**

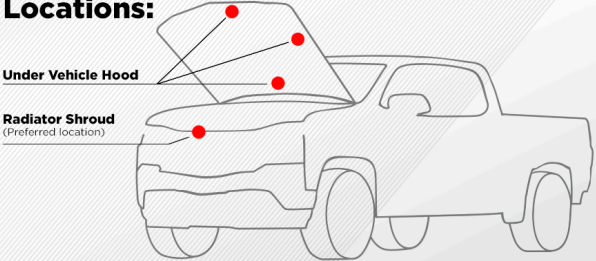

**Under Vehicle Hood**

**Radiator Shroud**  
(Preferred location)