

INSTALLATION INSTRUCTIONS
Forward Offset High Clearance A-Arms:
for Polaris Ranger[®] XP 1000

- Do not discard packaging until product has been successfully installed.

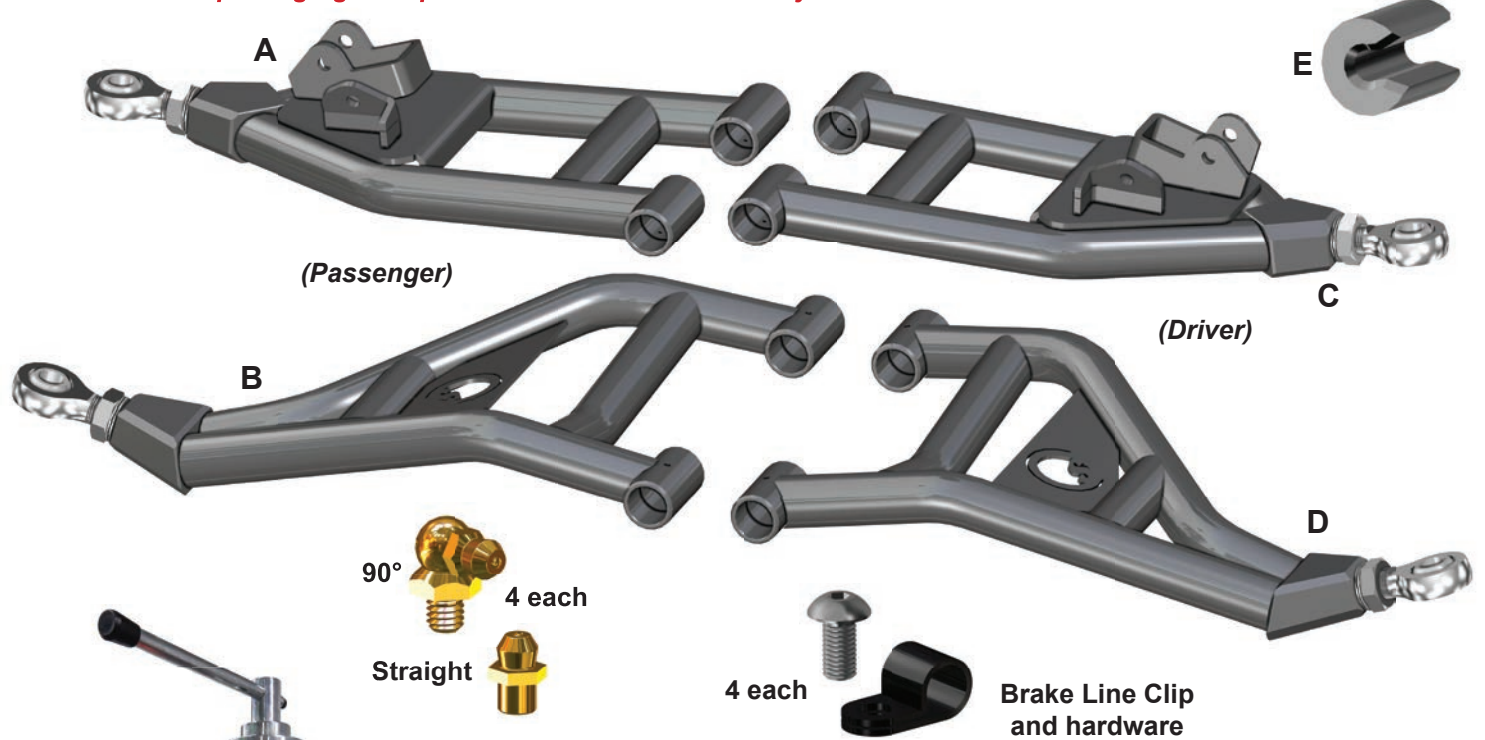

Item	Description
A	Passenger Upper
B	Passenger Lower
C	Driver Upper
D	Driver Lower
E	Bump Stop x 2



Steering Stops



2x - Upper Arm Stud kit

2x - Lower Arm Stud kit

SuperATV strongly recommends using a Spring Compressor when removing and installing Springs.

Need help with your installation?

✉ sales@superatv.com 🌐 www.superatv.com

☎ 1-855-743-3427 🕒 8:00am - 8:00pm EST M-Th
 8:00am - 7:00pm EST Friday
 9:00am - 2:00pm EST Saturday

Read instructions and view illustrations before beginning.

Thank You
 For Choosing
SUPERATV.COM[®]

Liability Statement

SuperATV's® products are designed to best fit user's ATV/UTV under stock conditions. Adding, modifying, or fabricating any factory or aftermarket parts will void any warranty provided by SuperATV® and is not recommended. SuperATV's® products could interfere with other aftermarket accessories. If user has aftermarket products on machine, contact SuperATV® to verify that they will work together.

Although SuperATV® has thousands of satisfied customers, user should be aware that installing lift kits, long travel, or suspension kits, tires, etc. will change the ride of machine and may increase maintenance and part wear. Operating any off-road machine while, or after, consuming alcohol and/or drugs increases risk of bodily harm or death. No warranty or representation is made as to this product's ability to protect user from severe injury or death. SuperATV® urges operators and occupants to wear a helmet and appropriate riding gear at all times.

By purchasing and installing SuperATV® products, user agrees that should damages occur, SuperATV® will not be held responsible for loss of time, use, labor fees, replacement parts, or freight charges. SuperATV®, nor any 3rd party, will not be held responsible for any direct, indirect, incidental, special, or consequential damages that result from any product purchased from SuperATV®. The total liability of seller to user for all damages, losses, and causes of action, if any, shall not exceed the total purchase price paid for the product that gave rise to the claim.

SuperATV® will warranty only parts provided by SuperATV®. Any damage or problems with OEM housings, bearings, seals, or other manufacturers' products will not be covered by SuperATV®. SuperATV® parts and products are not warranted if item was not installed properly, misused, or modified.

Installing, adding, modifying, or fabricating any factory or aftermarket product to your ATV/UTV may violate certain local, state, and federal laws. Be advised that laws vary depending on town, city, county, state, etc. Use of certain products on public streets, roads, or highways may be in violation law. The Buyer is solely and exclusively legally and personally responsible for any violation of the law by the installation or use of the product. You must abide by all local, state, and federal laws, including but not limited to vehicle safety, traffic laws, and ordinances. It is your responsibility to know the laws and how they apply to you.

The Buyer is responsible to fully understand the capability and limitations of his/her vehicle according to manufacturer specifications, warnings and instructions and agrees to hold SuperATV® harmless from any damage resulting from failure to adhere to such specifications, warnings and/ or instructions. The Buyer is also responsible to obey all applicable federal, state, and local laws and ordinances when operating his/her vehicle while using this product, and the Buyer agrees to hold SuperATV® harmless from any violation thereof.

Components Removal: *Keep all components removed from machine.*

Remove:

- Axle Nuts and Pins
- Tie Rods
- Brake Lines from A-Arms
- Shocks from machine
- Sway Bar Links from A-Arms
- Hubs
- Calipers
- A-Arms from Frame



(Passenger Side)

Bump Stop installation

- Place Shock into Spring Compressor.
- Remove Retaining Clip and Spring.
- Install Bump Stop (E).
- Reinstall previously removed components.
- Repeat for remaining Shock.

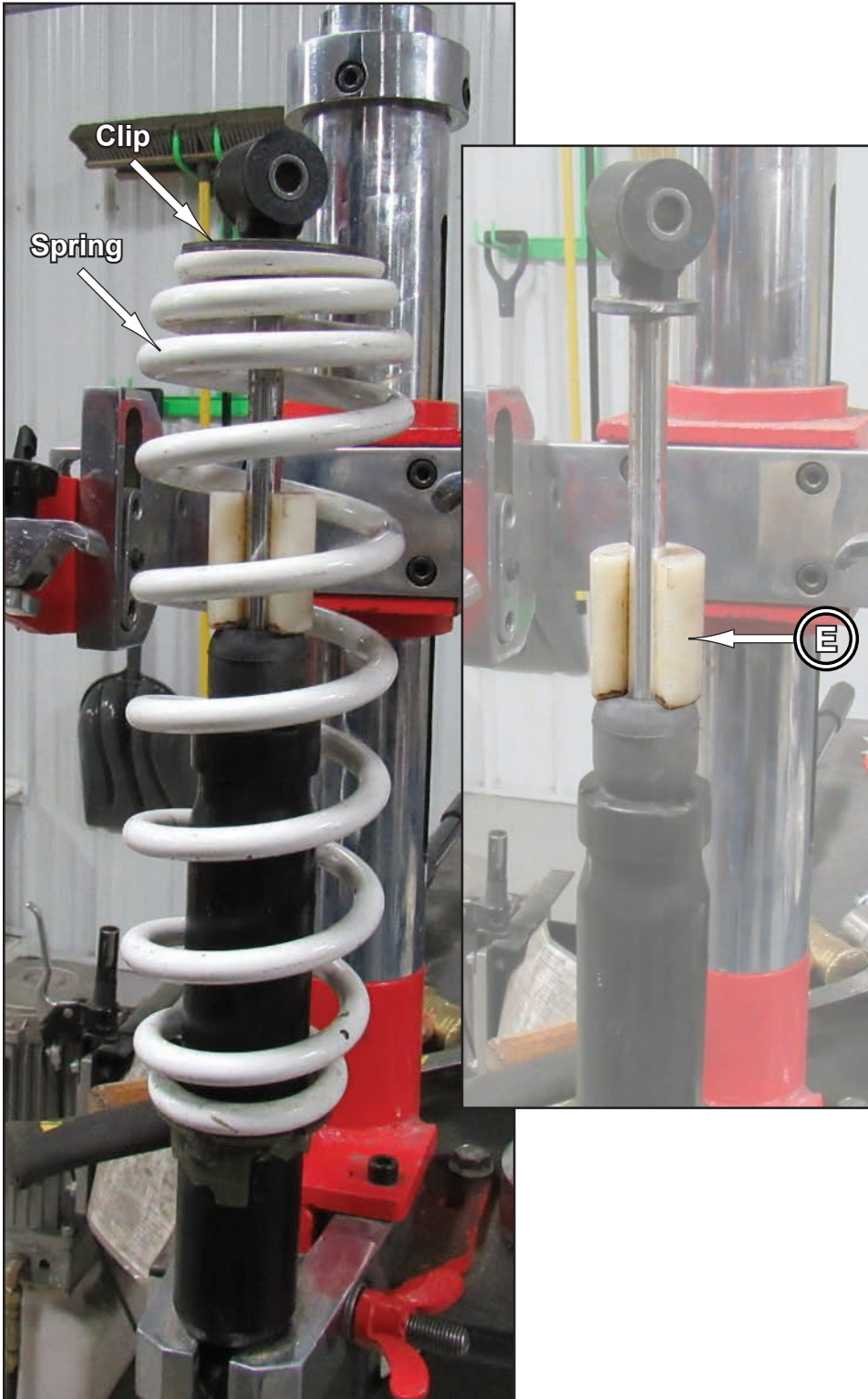

A-Arms Prep:

- Install provided Stud Kits into Heims; tighten hardware.



Upper Arm Stud kit

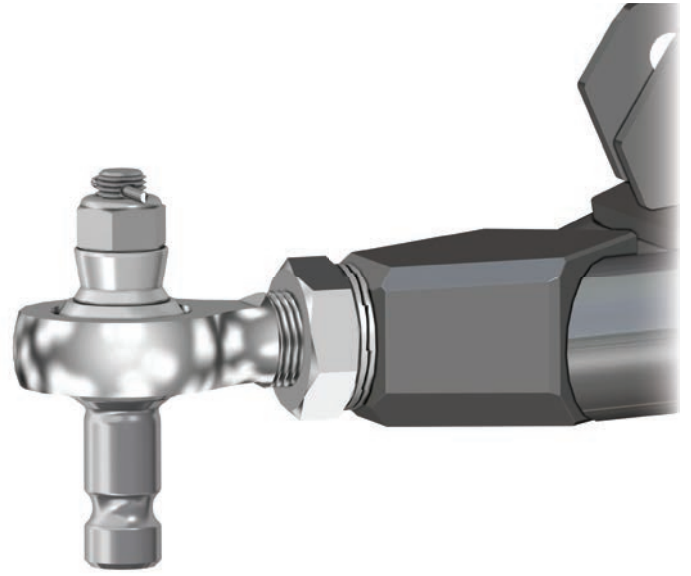

Lower Arm Stud kit

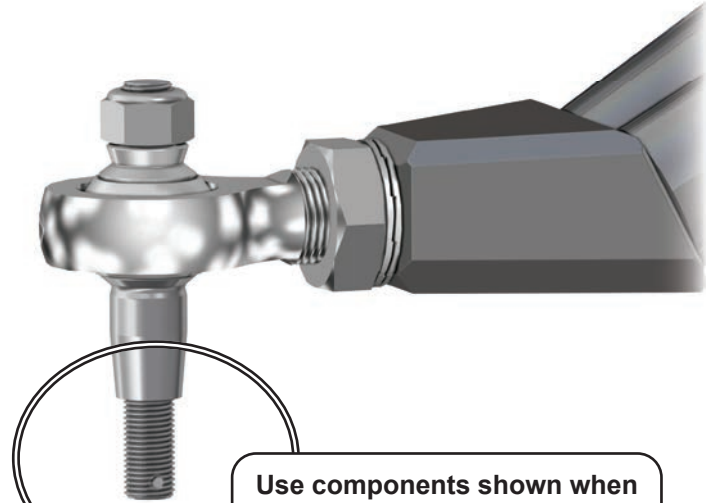

Use components shown when securing to Knuckle



A-Arms Prep continued: set aside when complete

- Install provided Fittings along with stock or SuperATV Bearings and Bushings into A-Arms.

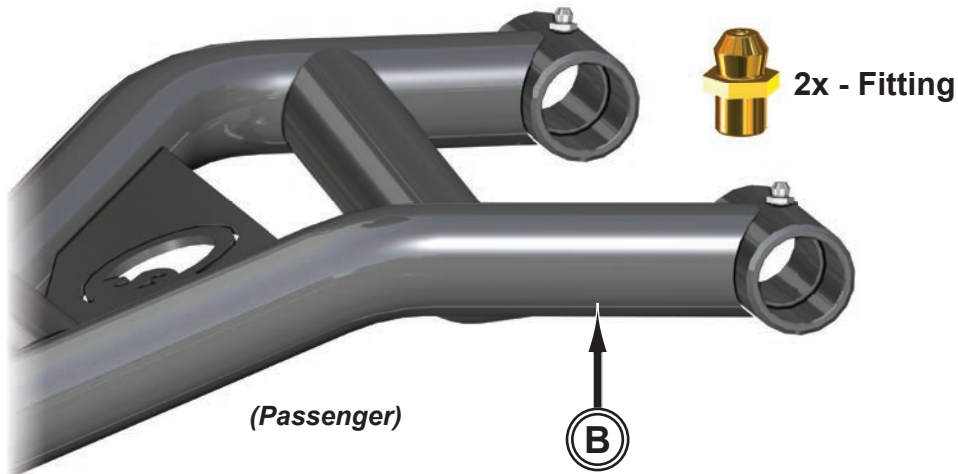
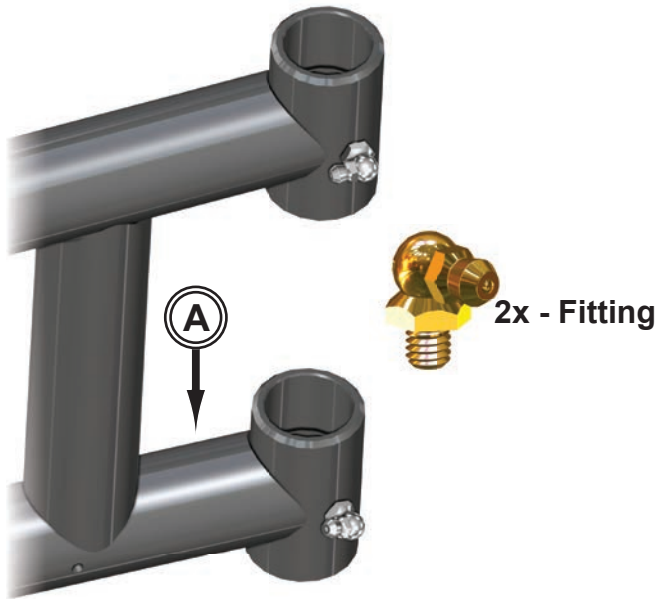

- Repeat for opposite A-Arms.

Steering Stop Installation: Rack and Pinion shown off machine for clarity.

- Install Bushings onto Shafts.
- Install Tie Rods; see following page.

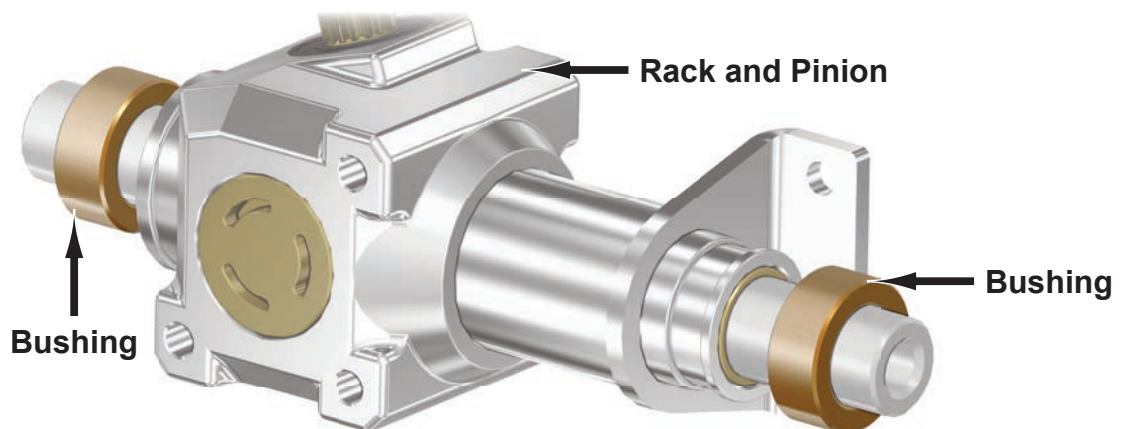

Tie Rod Installation:

- Install Ball and Sockets to Rack and Pinion. Use Loctite.
- Install Boots to Rack and Pinion and secure with Zip Ties.
- Install Jam Nuts to Ball and Sockets.
- Install Tie Rod Shafts to Ball and Sockets.
- Install Tie Rod Ends to Tie Rod Shafts.
- When securing Tie Rod Ends to Spindles, use hardware shown.

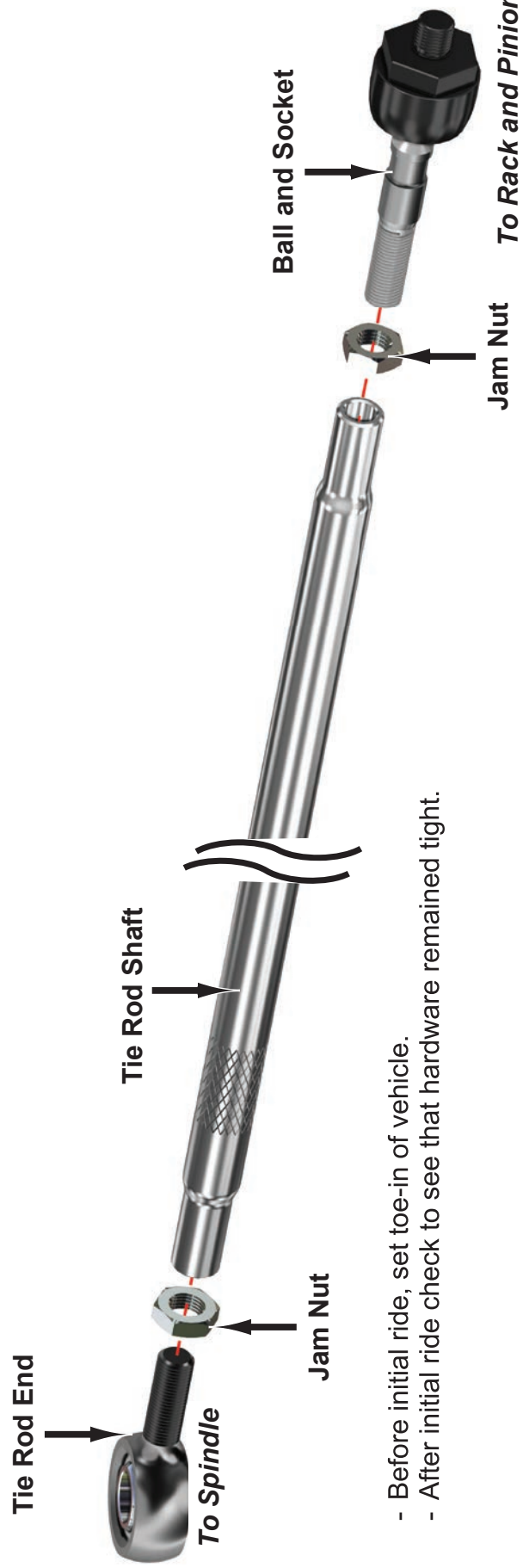
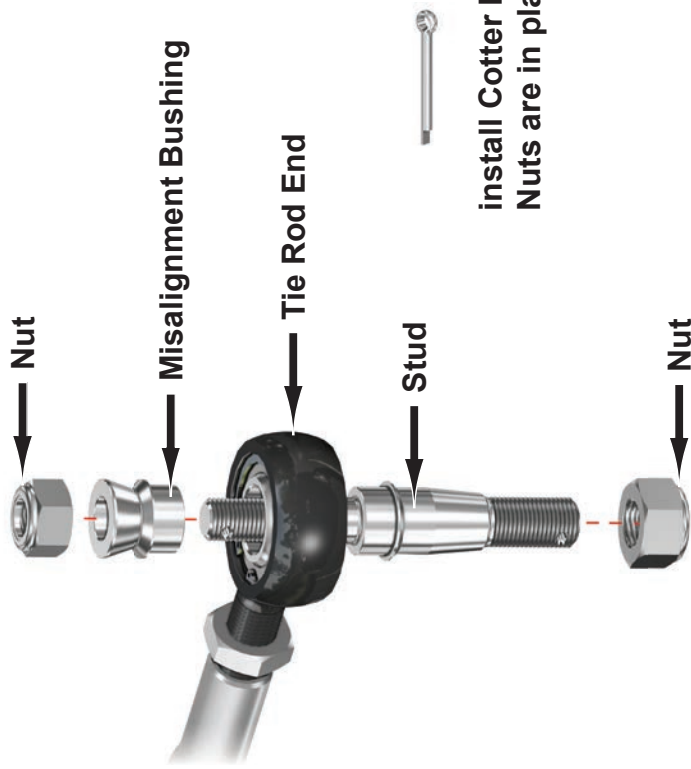

HEIM SETTINGS

- Place new A-Arms onto a flat surface and verify dimensions shown.
- *Negative 1° camber setting is achieved when Heims are set to this dimension.*

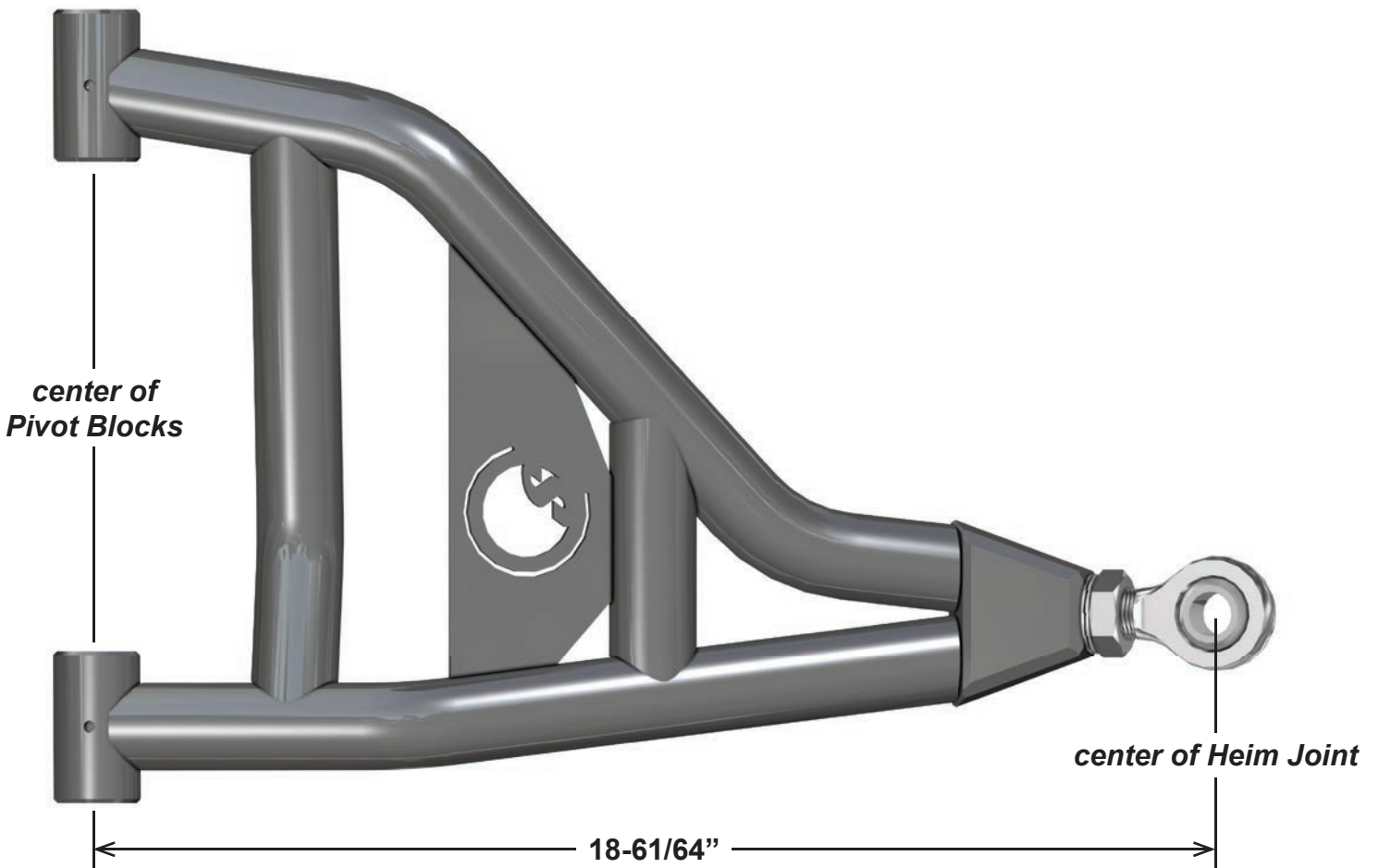
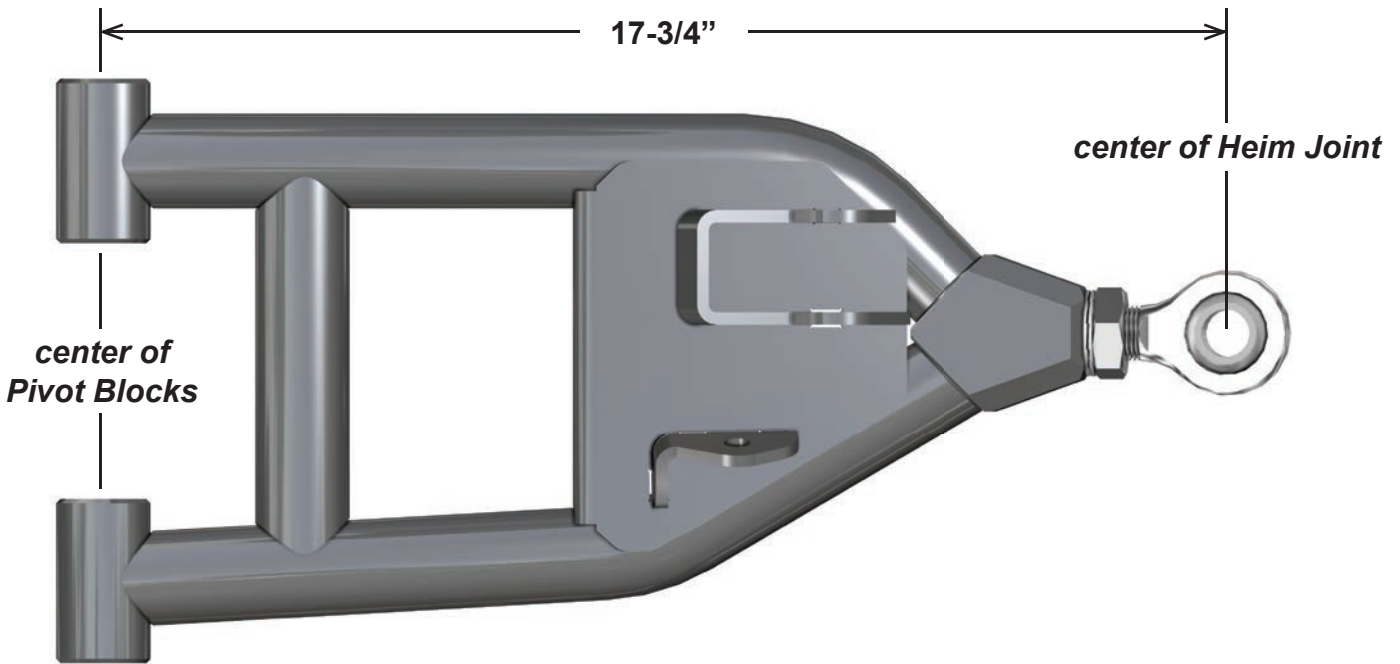

SuperATV recommends using Loc-Tite on Nuts.

- Install Driver Lower (D) to Frame with stock hardware; tighten.
- Install to Driver Upper (C) Frame with stock hardware; tighten.
- Repeat steps for opposite side.

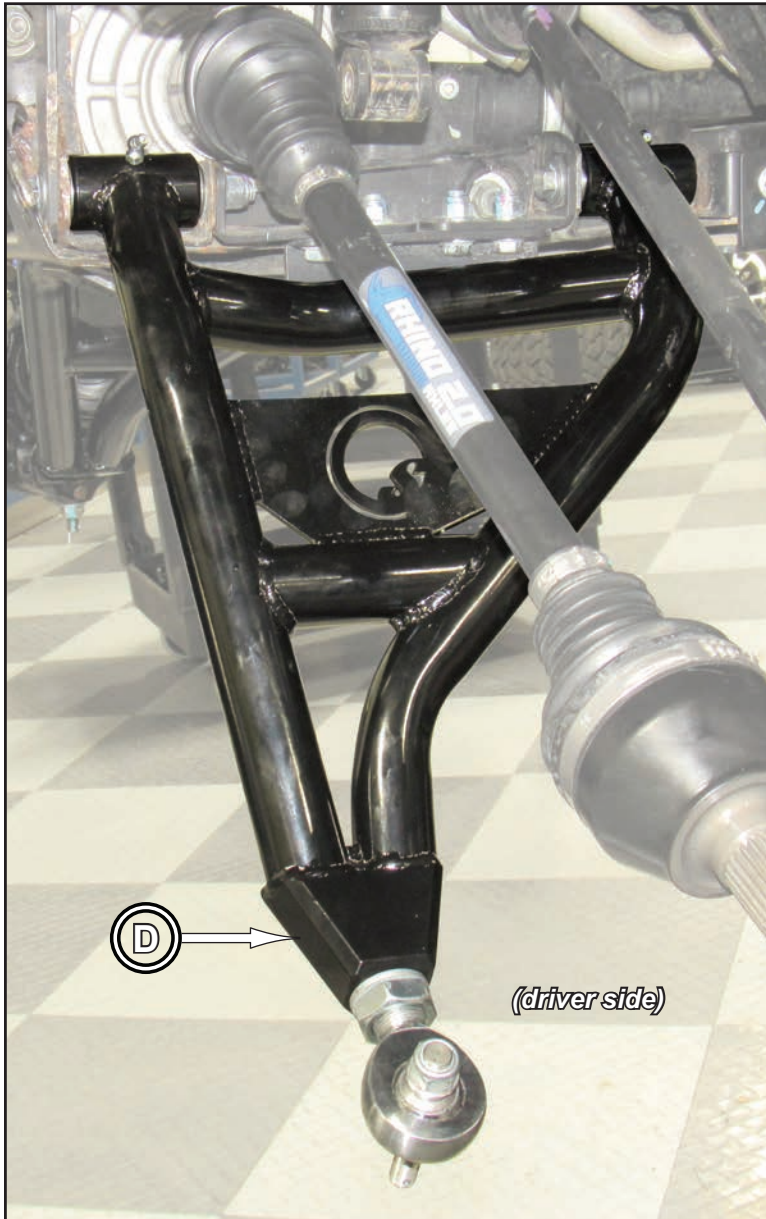

- Reinstall stock components to new A-Arms.

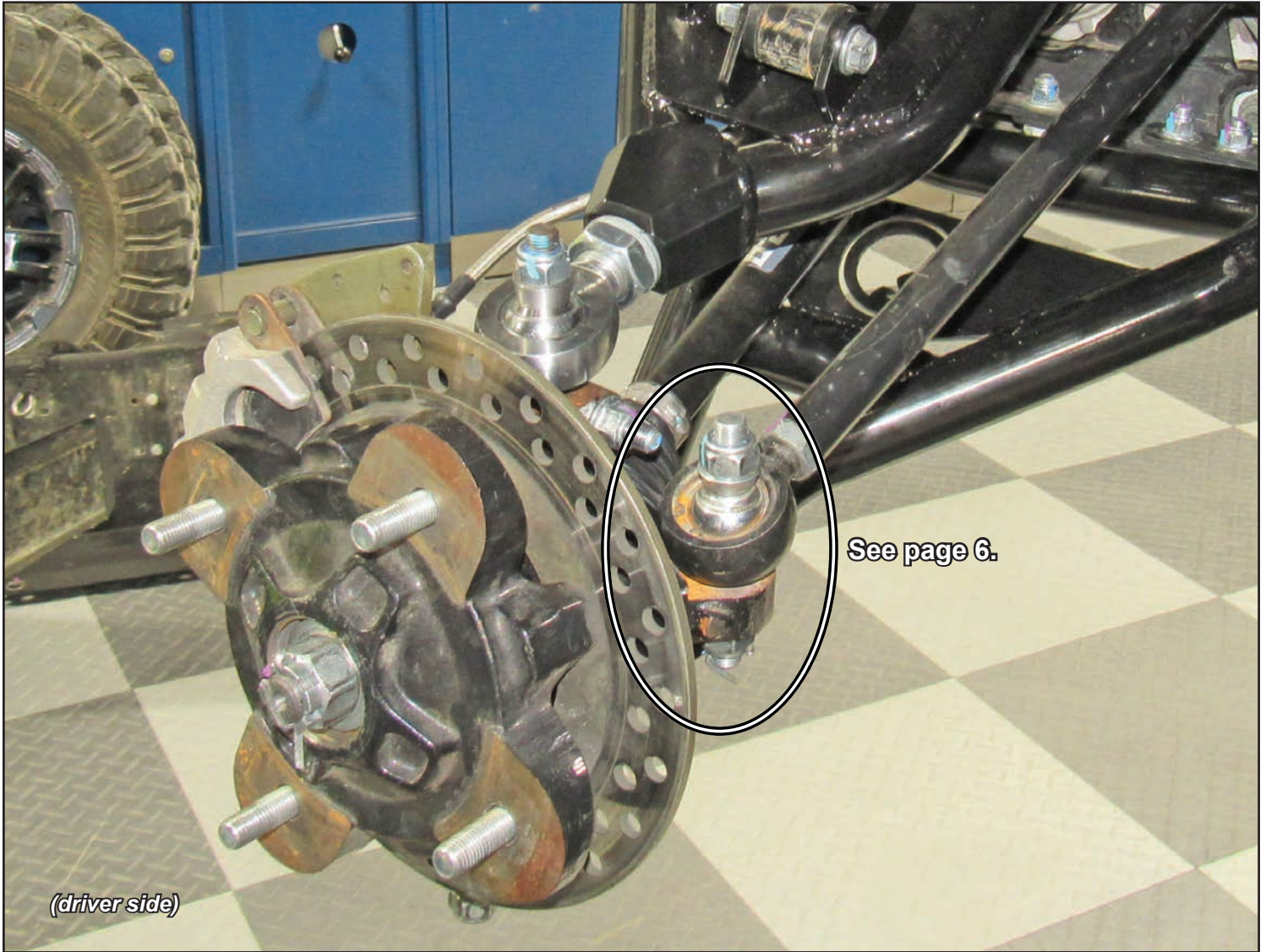

- Secure Brake Lines to locations shown on Upper Arms with hardware shown.
- Ensure no binding or rubbing can occur when in use.

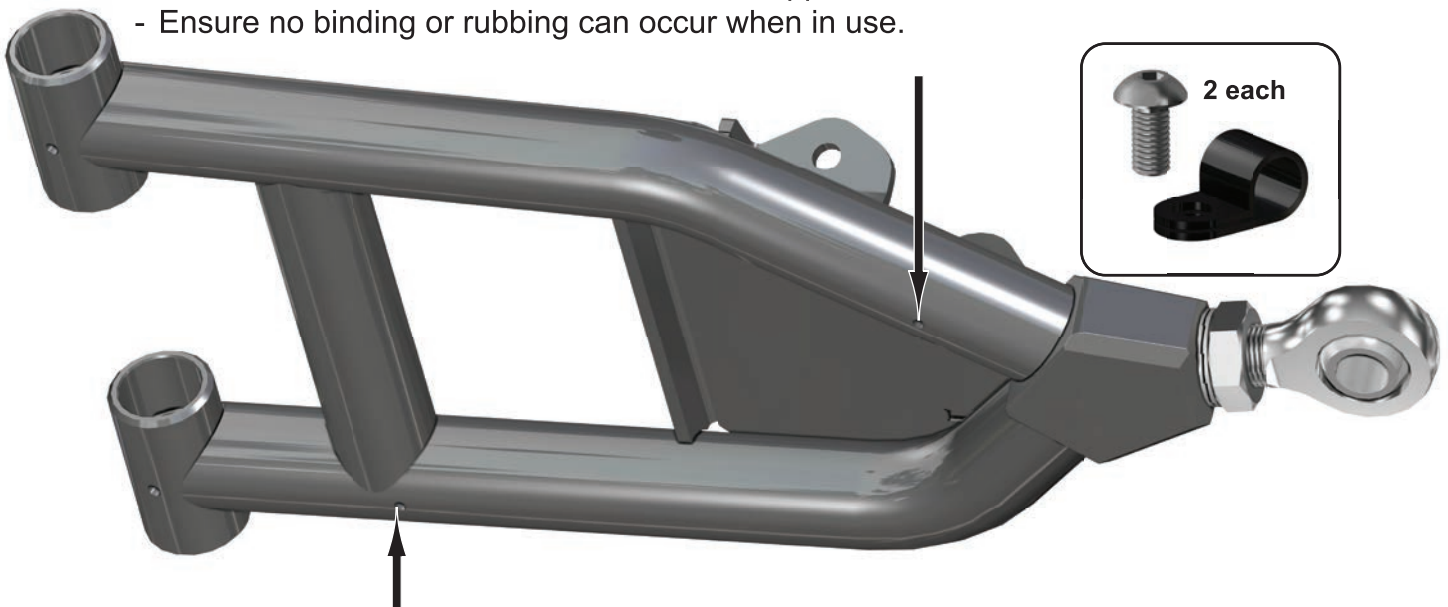

- Reinstall Tires and check Camber settings; see last page.
- Tighten all hardware completely and add Loc-Tite.

CAMBER

- Tires must have equal air pressure before making adjustments.
- Adjustments to be made after all suspension components have been completely assembled.
- Tires must not be in contact with ground when making adjustments.
- Perform adjustments in small increments.



Adjusting Camber:

- Remove A-Arms from Frame and turn Pivot Blocks to adjust camber. Reinstall Arms.
- Lower machine and settle suspension components by rolling machine back and forth several feet at a time.
- Check settings and make small adjustments as needed.
- Each time an adjustment is made, machine must be rolled back and forth to settle suspension components.
- Once desired setting is achieved, tighten hardware completely. Loc-tite on Nuts is recommended.

A NEGATIVE CAMBER SETTING OF 1° to 2° IS RECOMMENDED.

LOWER:

Too much positive camber: adjust Pivot Blocks **OUT**.

Too much negative camber: adjust Pivot Blocks **IN**.

note: 2 full turns is 1°

UPPER A-ARMS:

Too much positive camber: adjust Pivot Blocks **IN**.

Too much negative camber: adjust Pivot Blocks **OUT**.

note: 2 full turns is 1°

