

INSTALLATION INSTRUCTIONS

FS-P-XPD: Frame Stiffener

- Ⓢ Please look through and read these instructions BEFORE starting so you understand what processes you'll be doing, and possible extra tools you may need.
- Ⓢ Do Not discard product packaging until installation is complete and functioning properly.

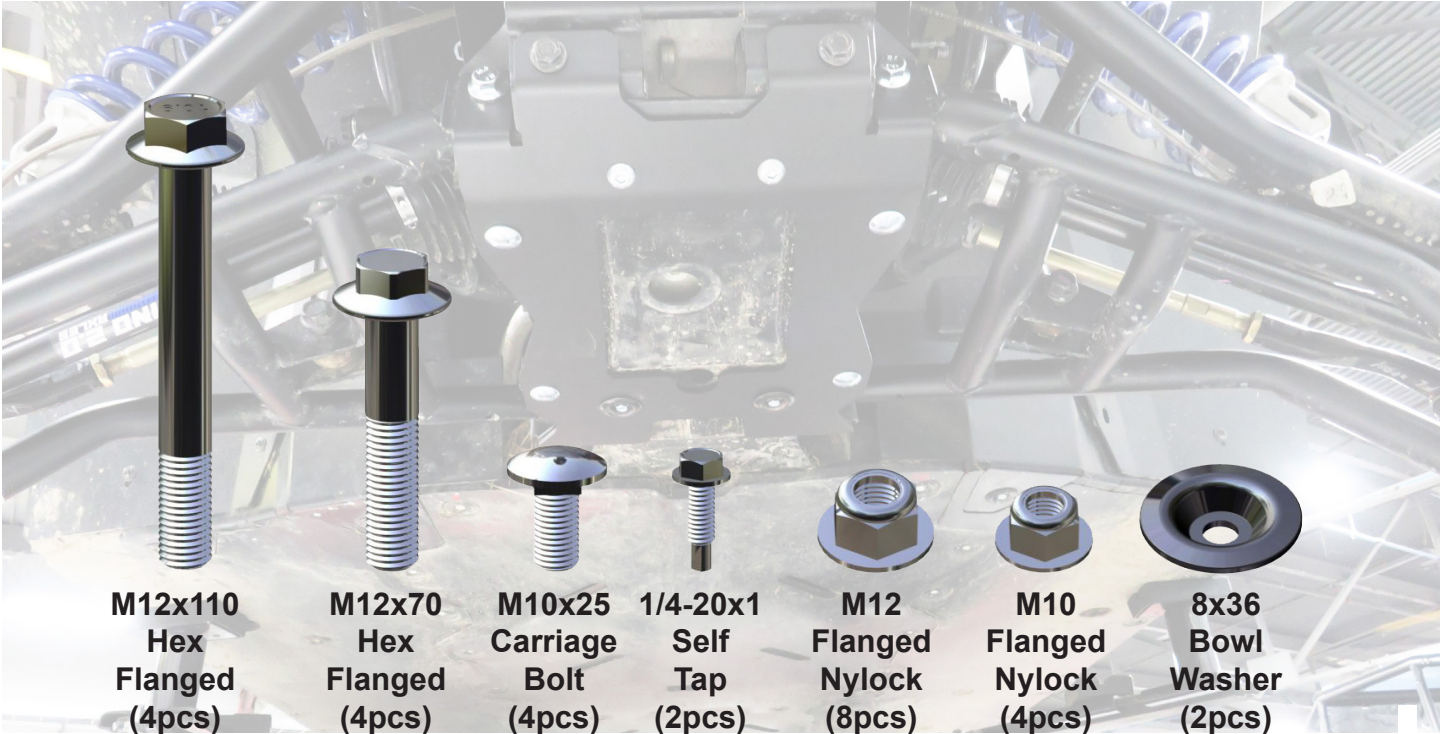
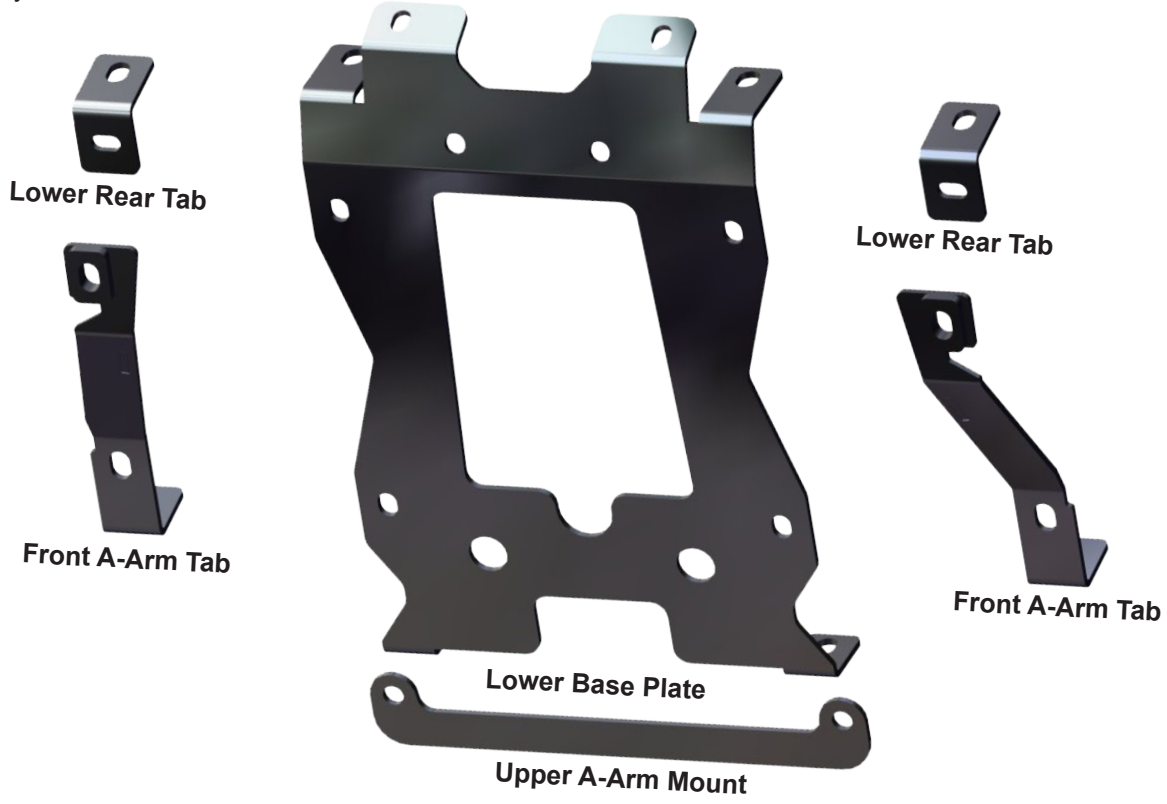

NOTE: Below is an assembly of all the parts and how they will be going together on your machine to give you an idea of where they go. Parts are also color tinted to show common parts. Also when installing Bolt and Nuts, do not tighten them down until ALL bolts & Nuts are installed. Then tighten down.

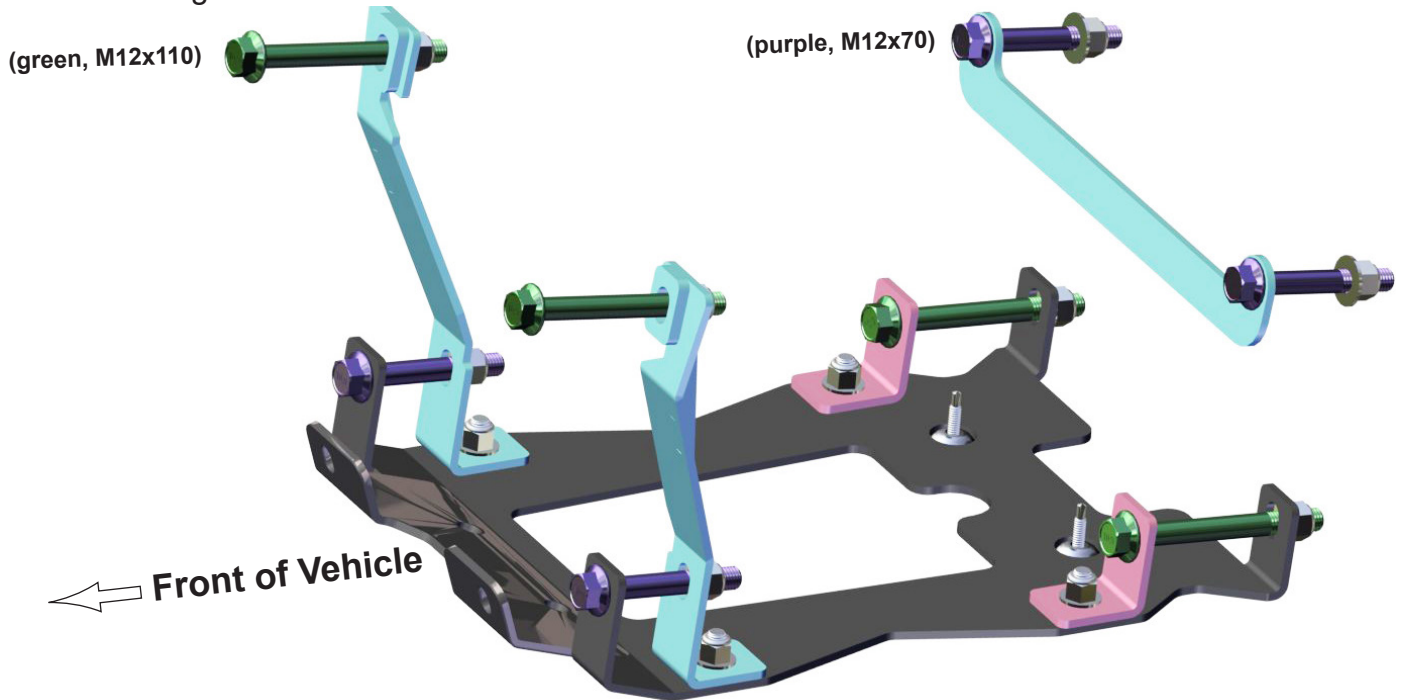

1. The first thing to do is to **Remove the Front Upper A-Arm Bolts** and replace them with the **M12x110 Bolts** from your kit as shown in **Fig.1a-b**. Repeat for opposite side.

NOTE: You may need to remove the Bumper & Winch to be able to have access for the installation.



Fig.1

2. Next **Remove The Lower A-Arm Bolts**, front and rear as shown in **Fig.2a-c**. Repeat for the opposite side and leave them out as you will be installing new bolts with other items in your kit.

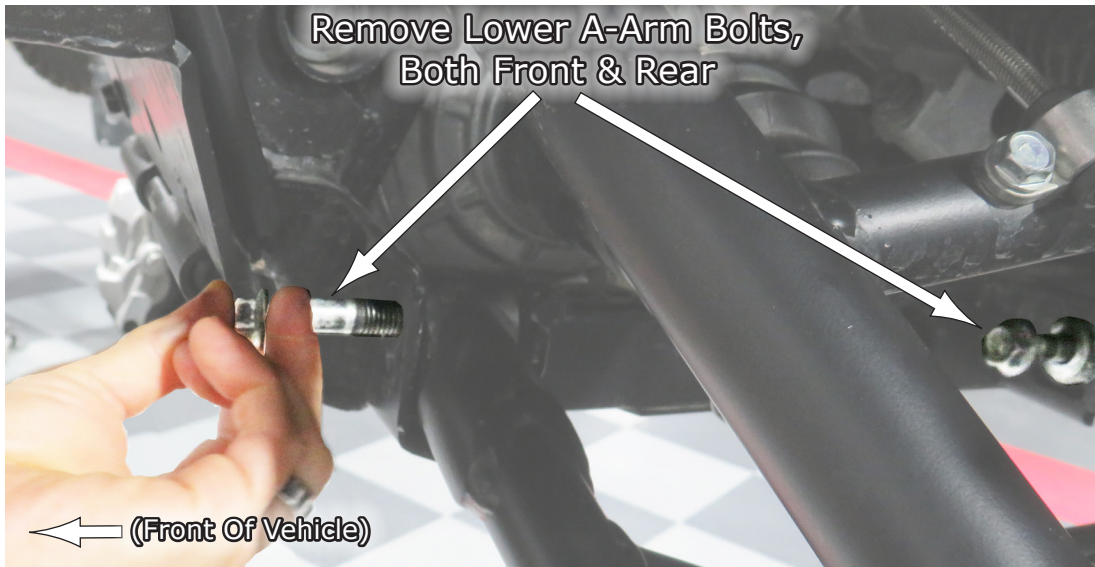

Fig.2a



Fig.2b



Fig.2c

3. Once the Lower Bolts are removed, then you will need to **Remove the Two (2) Bolts** from the front of the vehicle under the bumper area, if not already removed, as shown in **Fig.3a**.

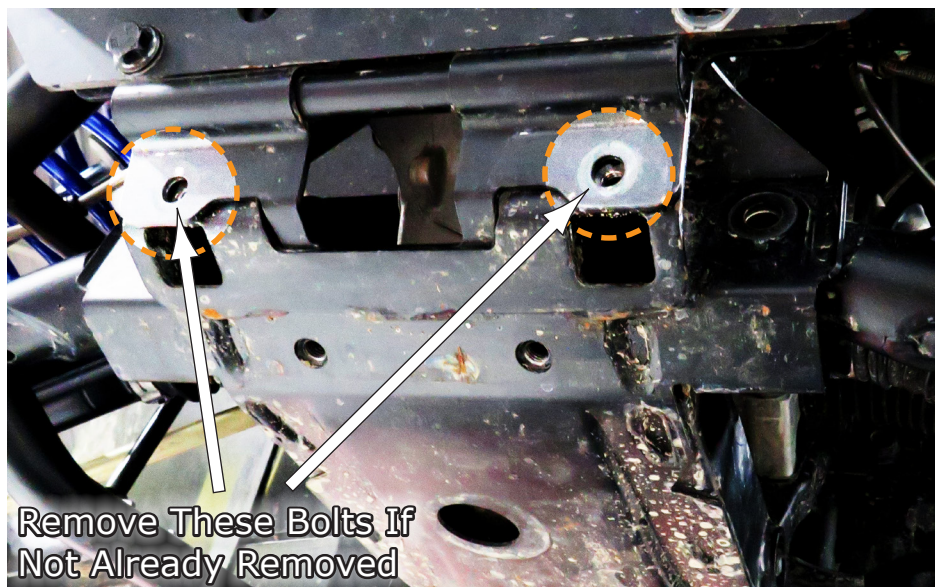

Fig.3a

4. Now **Place** the **Lower Base Plate** into position as shown in **Fig.4a**. Then you can install it using the factory bolts you removed from these two (2) locations as shown in **Fig.4b**.

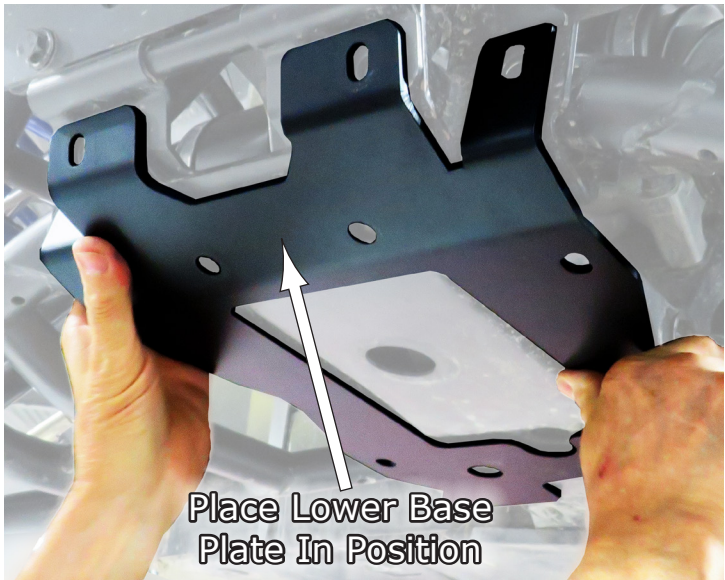

Fig.4a



Fig.4b

5. Next, you need to **Install** the **Lower Rear Tabs** using the **M12x110 Hex Flanged Bolts & M12 Nylock Nuts**, installing them to the rear lower A-Arm bolt location, as shown in **Fig.5a-b**. Then, install the **M10x25 Carriage Bolt** and **M10 Nylock Nuts** to the bottom location as shown in **Fig.5c-d**. Repeat for the opposite side.



Fig.5a

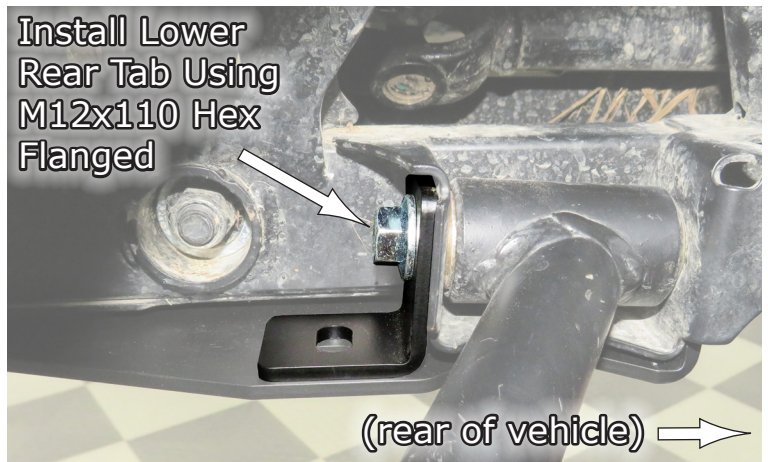

Fig.5a

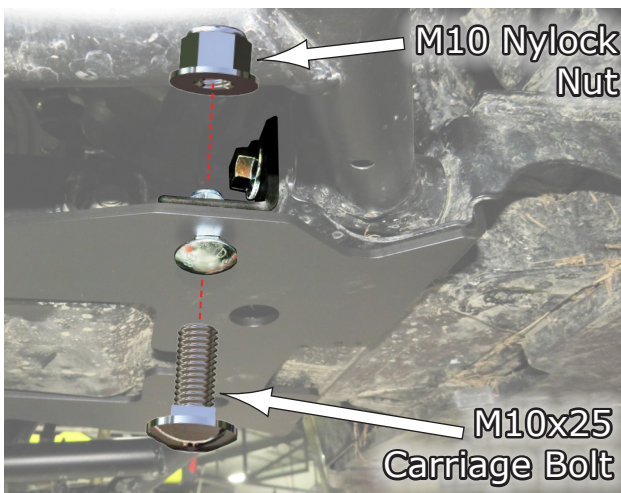

Fig.5c



Fig.5d

6. Next, find the **Front Arm Tabs**. These will install to the Front Upper and Lower A-Arm locations using the **M12x110 Bolts & M12 Nylock Nuts** for the upper, and the **M12x70 Bolts & M12 Nylock Nuts** for the lower location. See **Fig.6a-c**. Then **Install the M10x25 Carriage Bolts & M10 Nylock Nuts** as shown in **Fig.6d**. Repeat for opposite side.



Fig.6a



Fig.6b

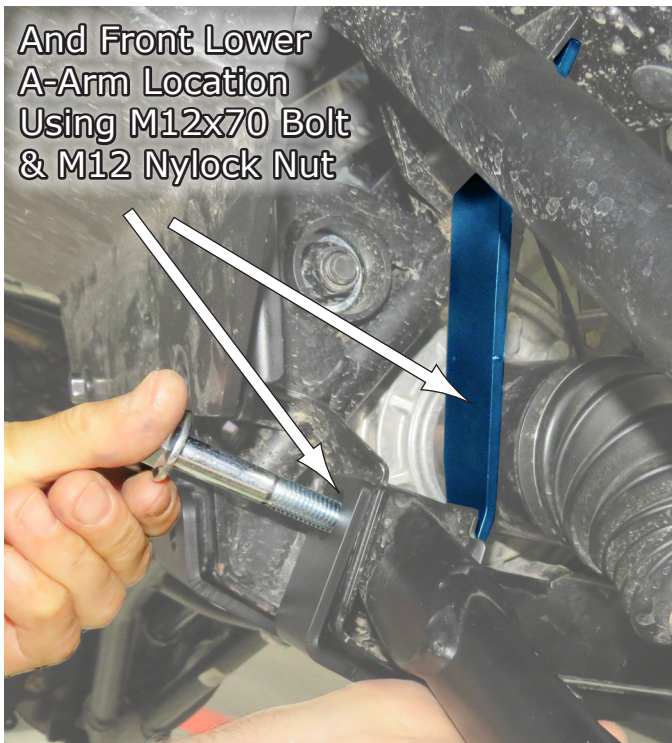

Fig.6c

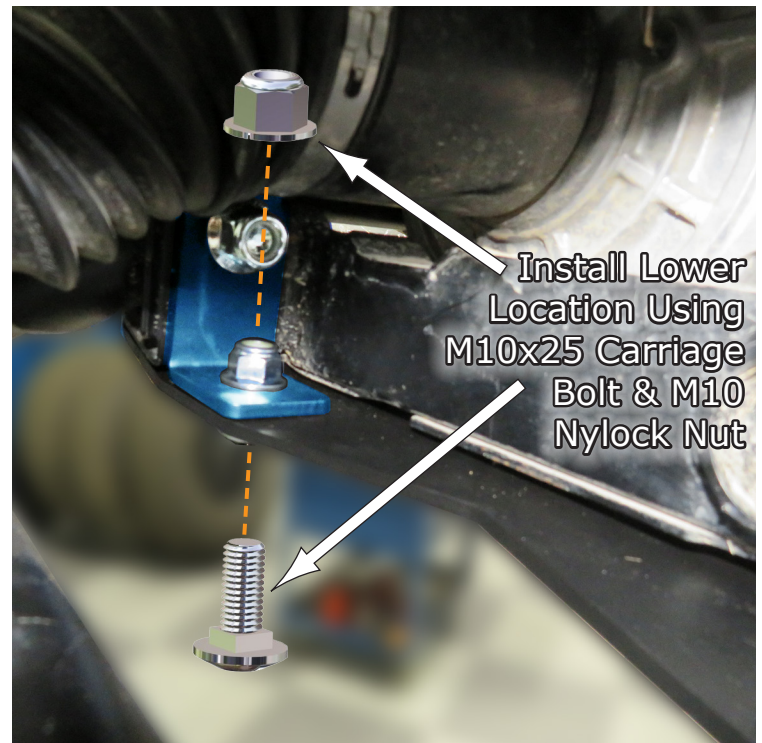

Fig.6d

7. Now, find the **Upper A-Arm Mount** as you will be installing it next. First, **Remove the Factory A-Arm Bolt** as shown in **Fig.7a**. Then **Install the Upper A-arm Mount** to the Upper Rear A-Arm connection points which goes across from one side to the other. Then install it using the **M12x70 Hex Flanged Bolts & M12 Nylock Nuts** as shown in **Fig.7b & d**.

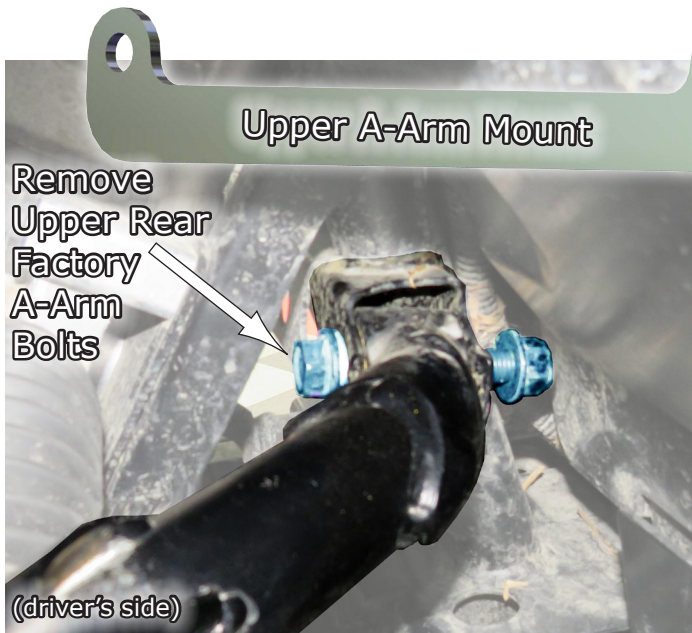

Fig.7a



Fig.7b



Fig.7c



Fig.7d



8. After the Upper Mount is in place, now go to the front of the vehicle and replace the Two (2) bolts you removed previously, as shown in **Fig.8a-b**.



Fig.8a

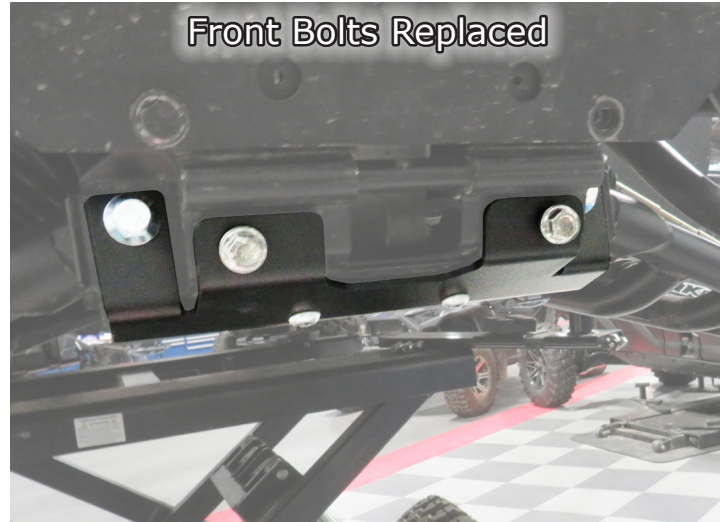

Fig.8a

9. We also added **Two (2) 1/4-20 Self Tap Screws** and **Bowl Washers** to cover the holes on the bottom of the Lower Base Plate if you wish to cover them up. However, they are not needed for this , only for looks and for your convenience should you choose to use them. See **Fig.9a-b**.

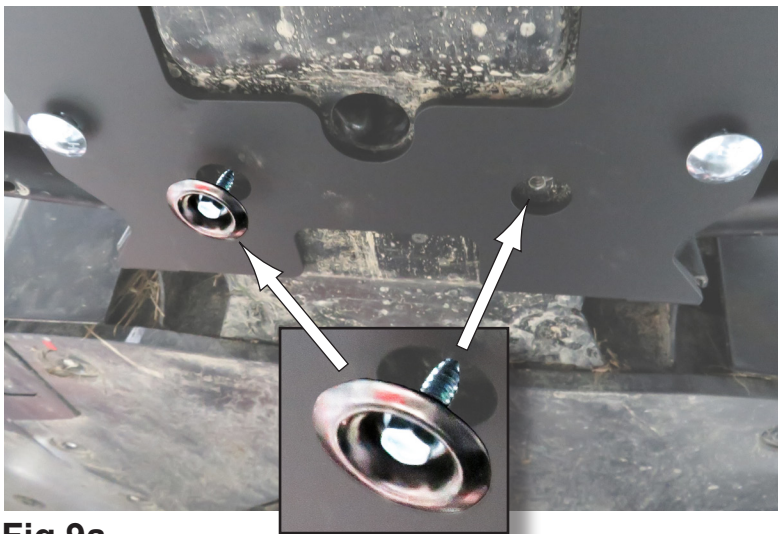

Fig.9a

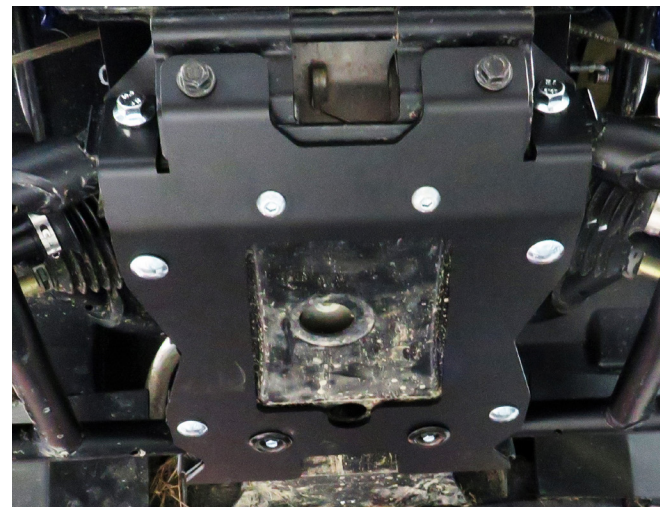

Fig.9b

10. Now go back and tighten up all bolts, screws and nuts secure, and replace any other components removed prior to starting the installation.



Liability Statement

SuperATV's® products are designed to best fit user's ATV/UTV under stock conditions. Adding, modifying, or fabricating any factory or aftermarket parts will void any warranty provided by SuperATV® and is not recommended. SuperATV's® products could interfere with other aftermarket accessories. If user has aftermarket products on machine, contact SuperATV® to verify that they will work together.

Although SuperATV® has thousands of satisfied customers, user should be aware that installing lift kits, long travel, or suspension kits, tires, etc. will change the ride of machine and may increase maintenance and part wear. Operating any off-road machine while, or after, consuming alcohol and/or drugs increases risk of bodily harm or death. No warranty or representation is made as to this product's ability to protect user from severe injury or death. SuperATV® urges operators and occupants to wear a helmet and appropriate riding gear at all times.

By purchasing and installing SuperATV® products, user agrees that should damages occur, SuperATV® will not be held responsible for loss of time, use, labor fees, replacement parts, or freight charges. SuperATV®, nor any 3rd party, will not be held responsible for any direct, indirect, incidental, special, or consequential damages that result from any product purchased from SuperATV®. The total liability of seller to user for all damages, losses, and causes of action, if any, shall not exceed the total purchase price paid for the product that gave rise to the claim.

SuperATV® will warranty only parts provided by SuperATV®. Any damage or problems with OEM housings, bearings, seals, or other manufacturers' products will not be covered by SuperATV®. SuperATV® parts and products are not warranted if item was not installed properly, misused, or modified.

Installing, adding, modifying, or fabricating any factory or aftermarket product to your ATV/UTV may violate certain local, state, and federal laws. Be advised that laws vary depending on town, city, county, state, etc. Use of certain products on public streets, roads, or highways may be in violation law. The Buyer is solely and exclusively legally and personally responsible for any violation of the law by the installation or use of the product. You must abide by all local, state, and federal laws, including but not limited to vehicle safety, traffic laws, and ordinances. It is your responsibility to know the laws and how they apply to you.

The Buyer is responsible to fully understand the capability and limitations of his/her vehicle according to manufacturer specifications, warnings and instructions and agrees to hold SuperATV® harmless from any damage resulting from failure to adhere to such specifications, warnings and/ or instructions. The Buyer is also responsible to obey all applicable federal, state, and local laws and ordinances when operating his/her vehicle while using this product, and the Buyer agrees to hold SuperATV® harmless from any violation thereof.

If you have any problems/questions on this kit, contact us by email at Superatv.com.

Need help with your installation?



sales@superatv.com



www.superatv.com



1-855-743-3427



8:00am - 9:00pm EST M-Th
8:00am - 7:00pm EST Friday
9:00am - 2:00pm EST Saturday

*Thank You
For Choosing*



Like SuperATV on Facebook to keep up to date on new products!