

Do not discard packaging until product has been successfully installed.



Wire Ties

Adadpter x 2



Tubing



Ducting



Blower



Y Fitting



90° Elbow



4x Large Clamp



8x Small Clamp



Vent x 4

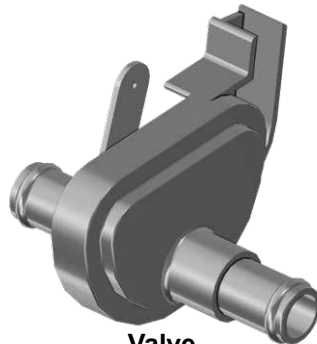

Valve



Adapter x 3



Switch



2x Grommet



Knob

(kit contents continue on following page)

Need help with your installation?



sales@superatv.com



www.superatv.com



1-855-743-3427



8:00am - 8:00pm EST M-Th
 8:00am - 7:00pm EST Friday
 9:00am - 2:00pm EST Saturday

Read instructions and view illustrations before beginning.

*Thank You
 For Choosing*



(kit contents continued)

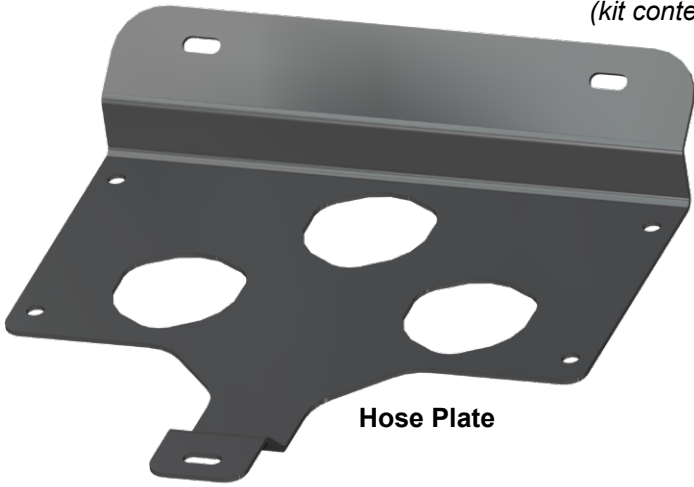

Hose Plate

Glove Box Plate

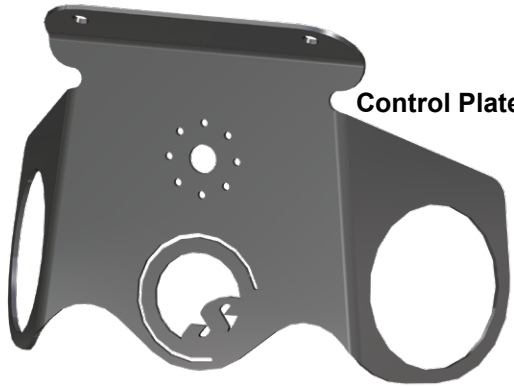
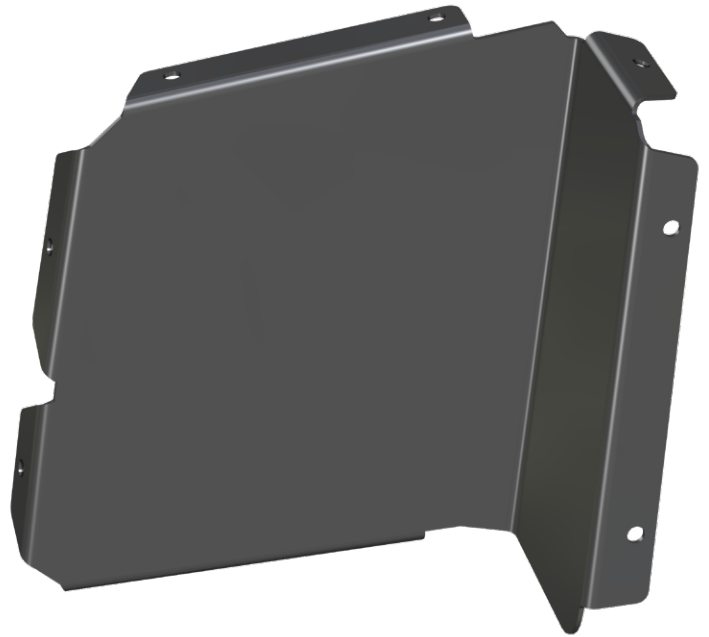

Control Plate



Back Plate



Bracket

RED = POS "+"
BLACK = NEG "-"
WHITE = 12V switched key-on source

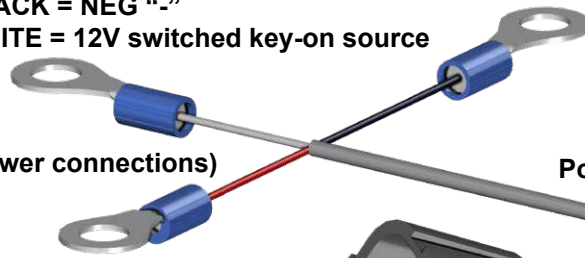

(to Power connections)

Power Harness

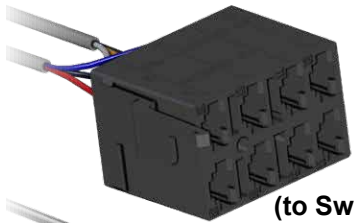

(to Switch)

Blower Harness

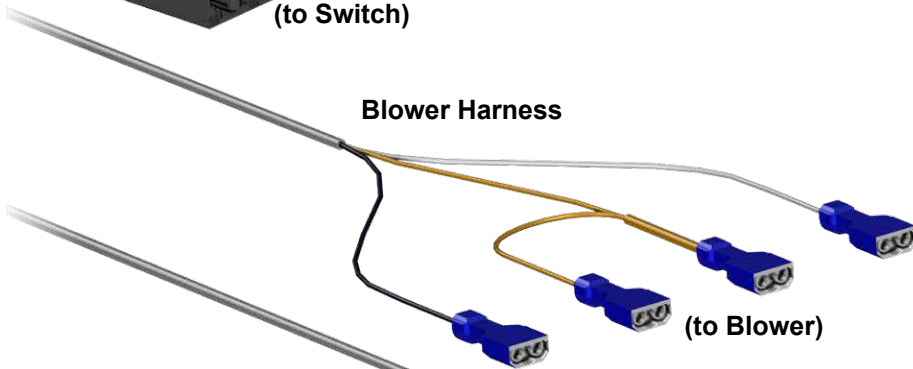

(to Blower)

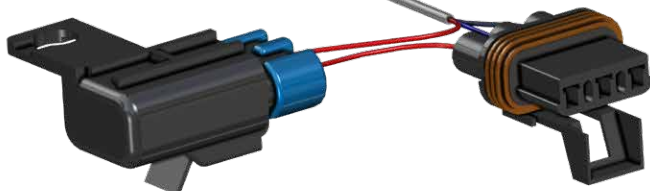
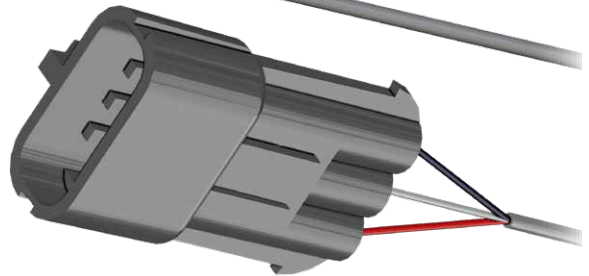

(to Power Harness)

- *Tubing and Duct lengths are SuperATV recommended. User may install components in other locations. Verify lengths before final installation.*
- *Check behind areas being drilled for interference.*
- *Avoid burns and scalding by working on cool vehicles.*
- *Secure components away from rotating objects.*
- *Do not tighten mounting hardware until all components are in place.*
- *Use manufacturers recommended coolant.*
- *Avoid sharp bends when installing Tubing.*
- *Verify that no leaks are present after installation.*

CUSTOMER NOTIFICATION AND DISCLAIMER LIABILITY

This product is a modification for utility task vehicles and all terrain vehicles. Use this product at your own risk.

Warranty and Liability Limitations. The Buyer hereby assumes all risks associated with the use and/or installation of this product. Buyer waives all liability claims against SuperATV® of any kind or nature, including, but not limited to, liability for penalties, fines, property damage, personal injury or death, to the fullest extent permitted by law. Buyer acknowledges and agrees that SuperATV® is not liable for any direct, indirect, incidental, consequential or special damages, including but not limited to, damage, loss of life, loss of property or equipment, loss of profits or revenue, injury, or claims from any individual or entity arising from the use of this product.

The warranty for this product, if any, may give you ("Buyer") specific legal rights, and Buyer may also have other rights which may vary from state to state. The installation of this product may void or otherwise adversely affect your factory warranty.

Consult your vehicle warranty before using this Product. Under no circumstances will SuperATV® be liable for the voidance of the Buyer's vehicle warranty. Buyer assumes all risk and responsibility if a manufacturer and/or dealer voids the Buyer's vehicle warranty due to use of this Product.

Safety and Laws. Operate your vehicle at all times in a safe manner. You must abide by all local, state, and federal laws, including but not limited to vehicle safety, traffic laws, and ordinances. It is your responsibility to know the laws and how they apply to you. The installation of this product may violate certain local, state, and federal laws. Be advised that laws vary depending on town, city, county, state, etc. Use of this product on public streets, roads, or highways may be in violation law. The Buyer is solely and exclusively legally and personally responsible for any violation of the law by the installation or use of this product. In no case will SuperATV® be held liable if Buyer violates the law or uses the product in an unsafe manner.

The Buyer is responsible to fully understand the capability and limitations of his/her vehicle according to manufacturer specifications, warnings and instructions and agrees to hold SuperATV® harmless from any damage resulting from failure to adhere to such specifications, warnings and/ or instructions. The Buyer is also responsible to obey all applicable federal, state, and local laws when operating his/her vehicle while using this product, and the Buyer agrees to hold SuperATV® harmless from any violation thereof.

Installation. The installation of this product on your vehicle indicates that you have had the opportunity to inquire about applicable local, state, and federal laws and ordinances and that you have read and understand, and accept all of the terms of, this Disclaimer.

SuperATV® shall not be responsible for the proper installation, use, and service of this product. Rather, the Buyer shall be solely responsible for the installation of the product and any damage that may be done to the vehicle or vehicle components as a result of modifications made by the Buyer.

this page intentionally blank

Firewall Hose Template

- Follow profile and cut template.
- Attach to location shown on page 13 with tape.
- Mark centers, remove, and cut (2) $\text{Ø}1\text{-}1/4\text{'}$ holes.

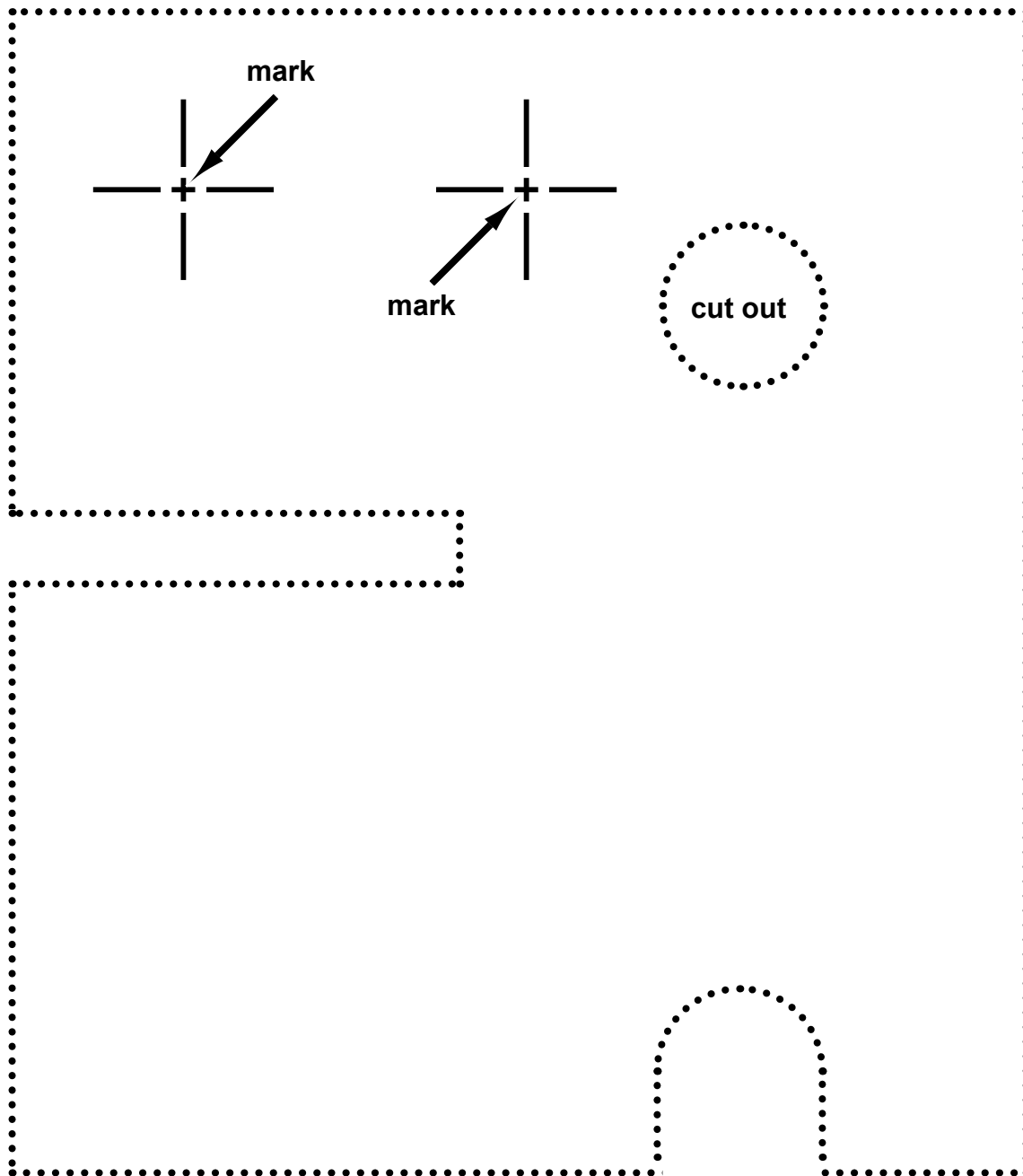

this page intentionally blank

- Follow profile and cut template.
- Attach to location shown on pages 16 and 17 with tape.

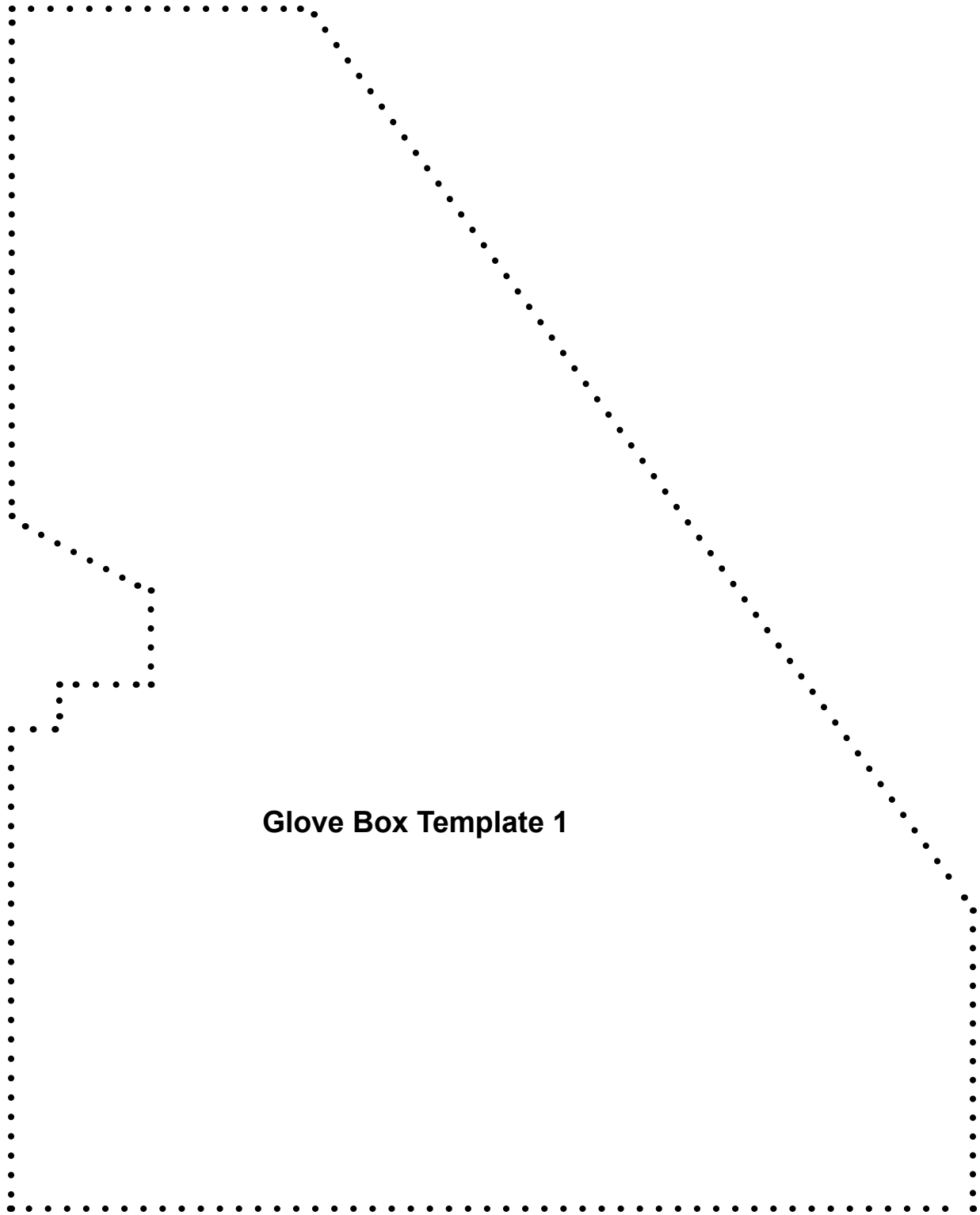

Glove Box Template 1

this page intentionally blank

- Follow profile and cut template.
- Attach to location shown on page 16 with tape.

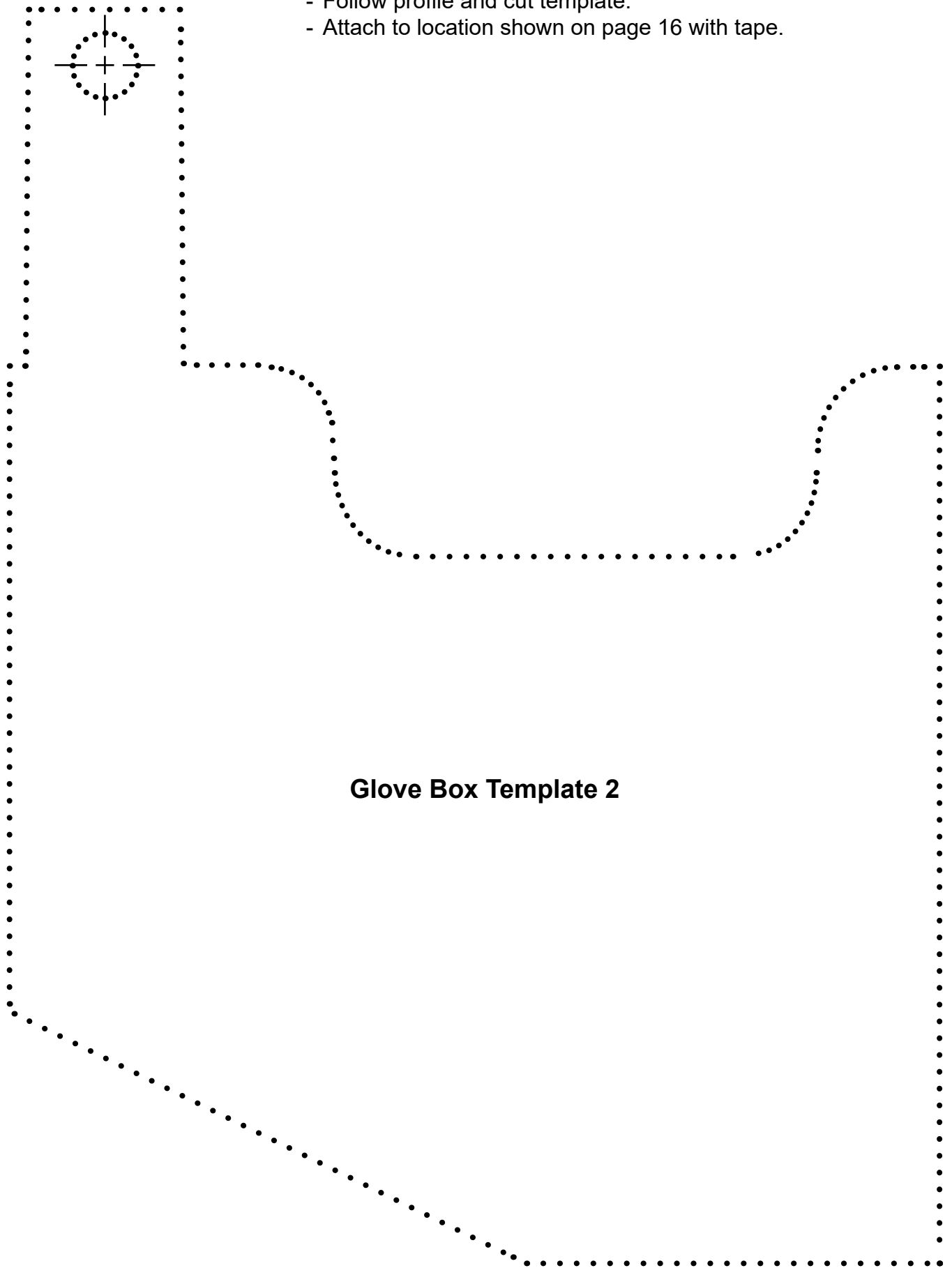

Glove Box Template 2

this page intentionally blank

- Follow profile and cut template.
- Attach to location shown on pages 16 and 17 with tape.

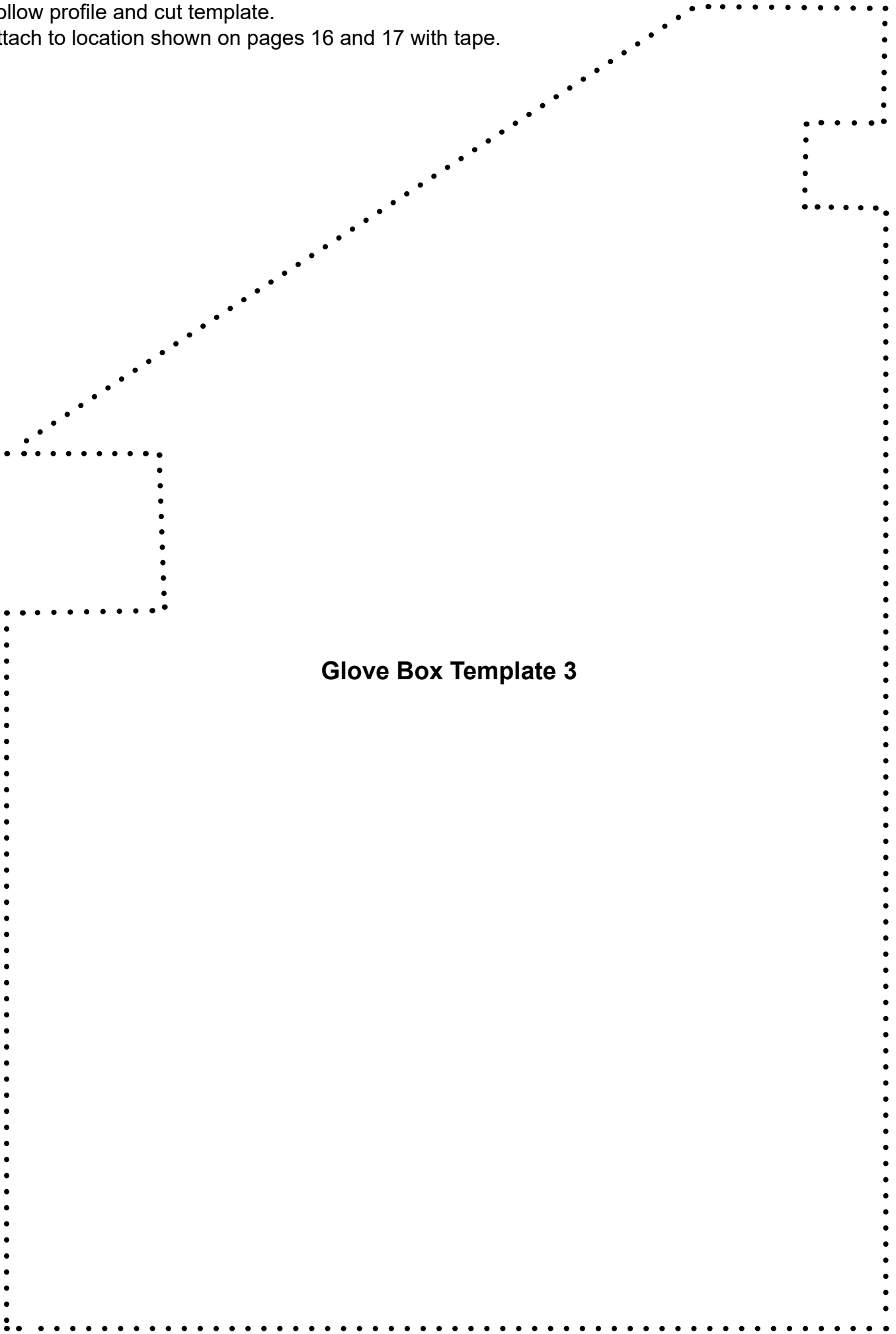

Glove Box Template 3

this page intentionally blank

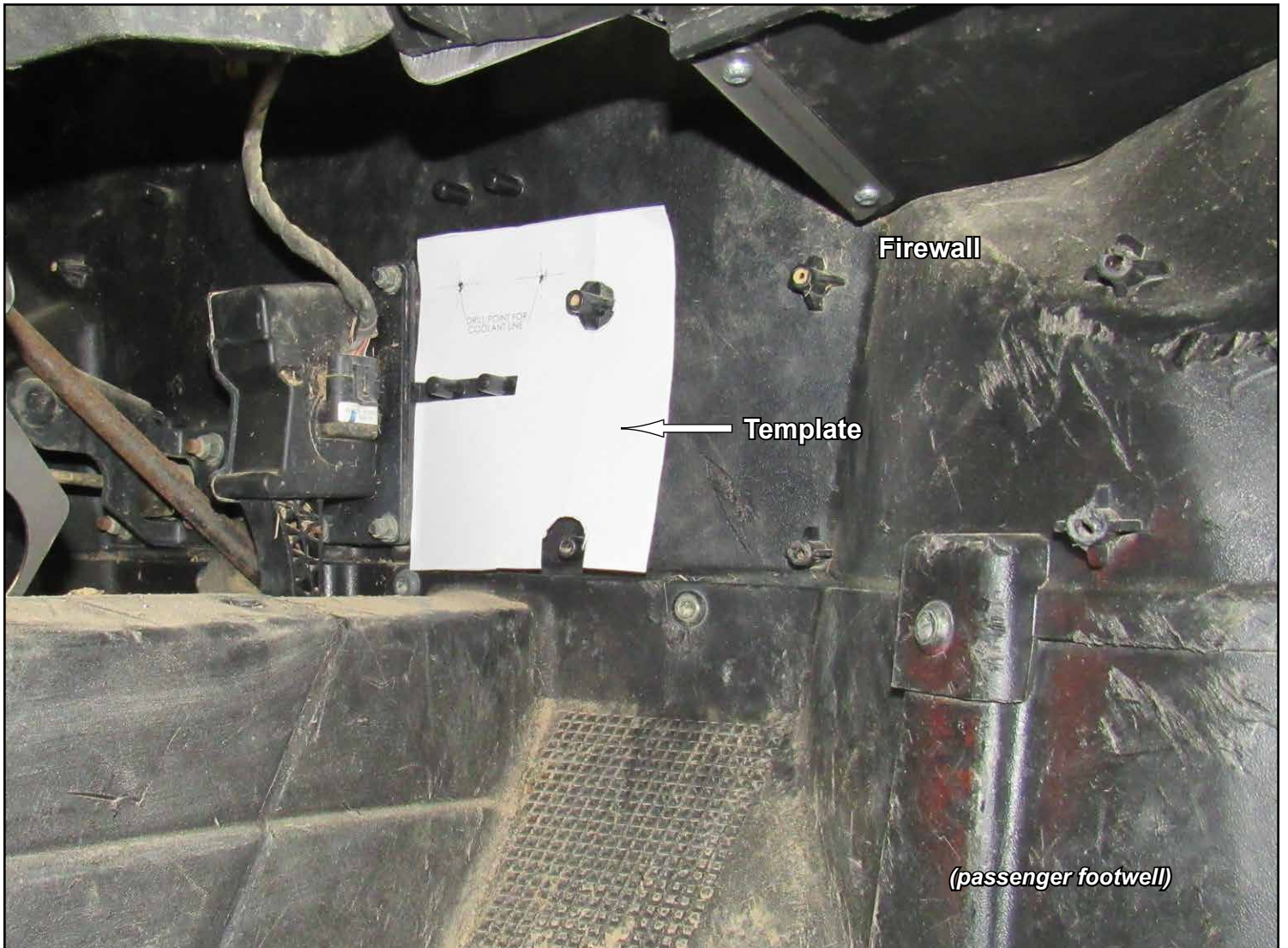

- Mark locations for Grommets and cut (2) Ø1-1/4" holes through Firewall.

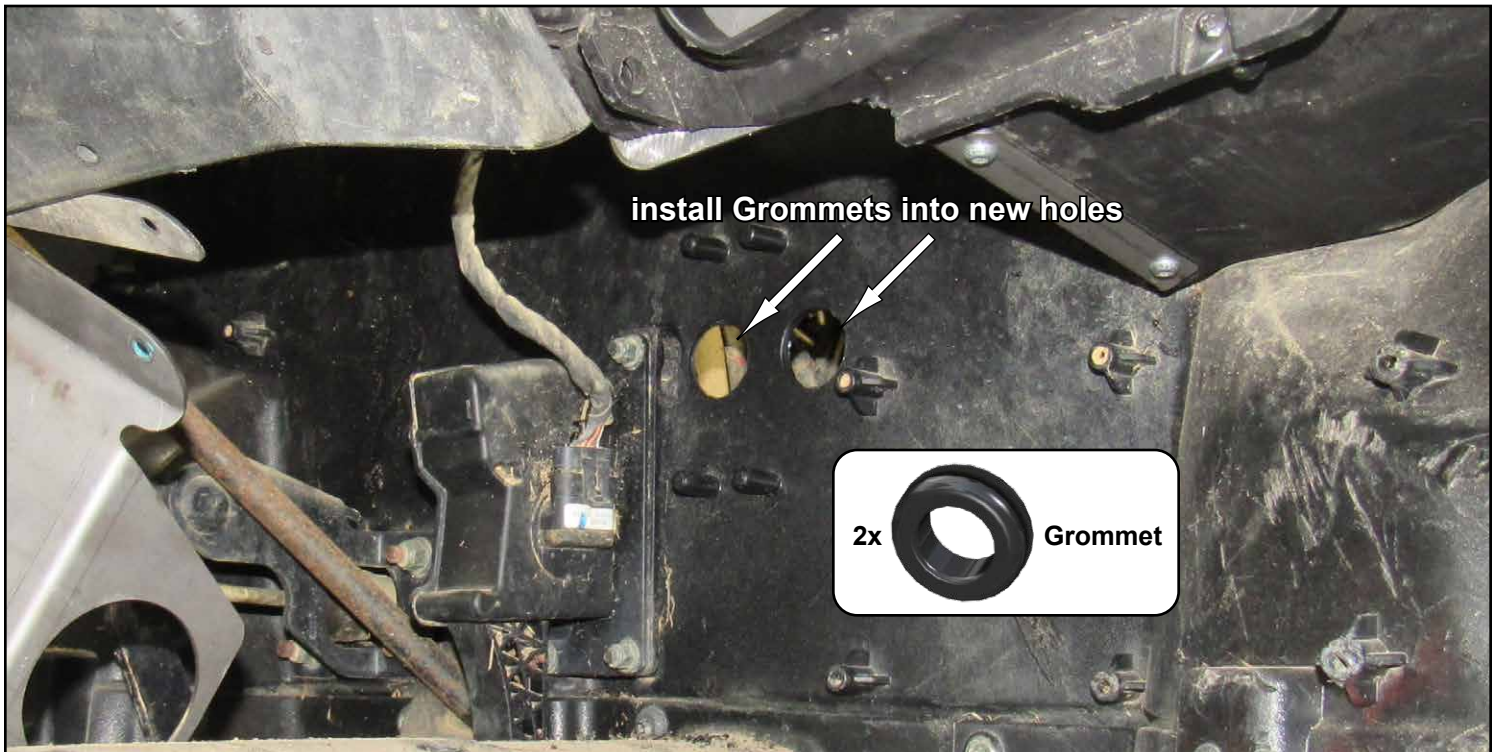

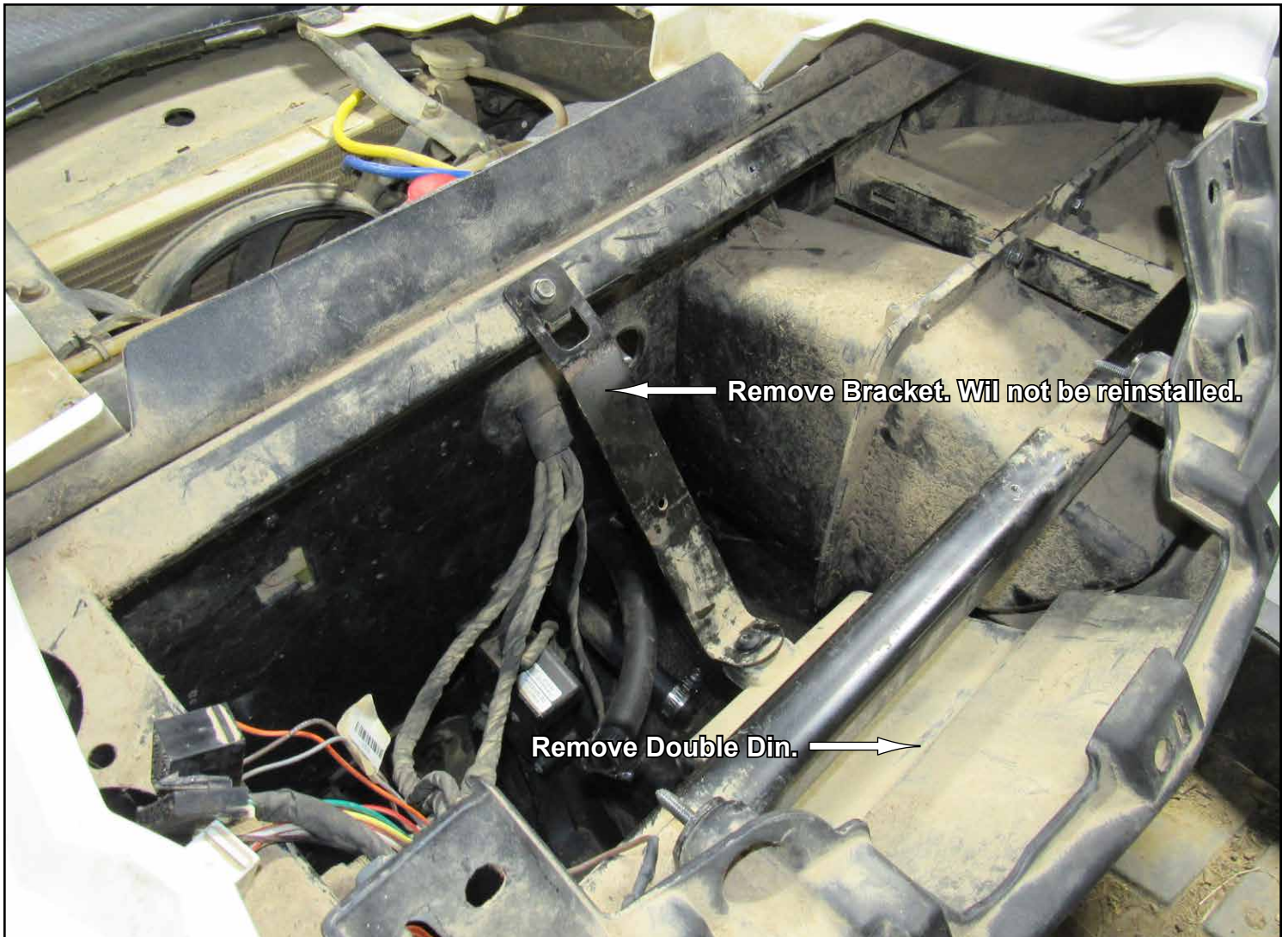



- Install Bracket to Double Din with hardware shown; tighten.



- Tape Templates 2 and 3 into position.
- Use a straight edge and marker to make lines as shown.

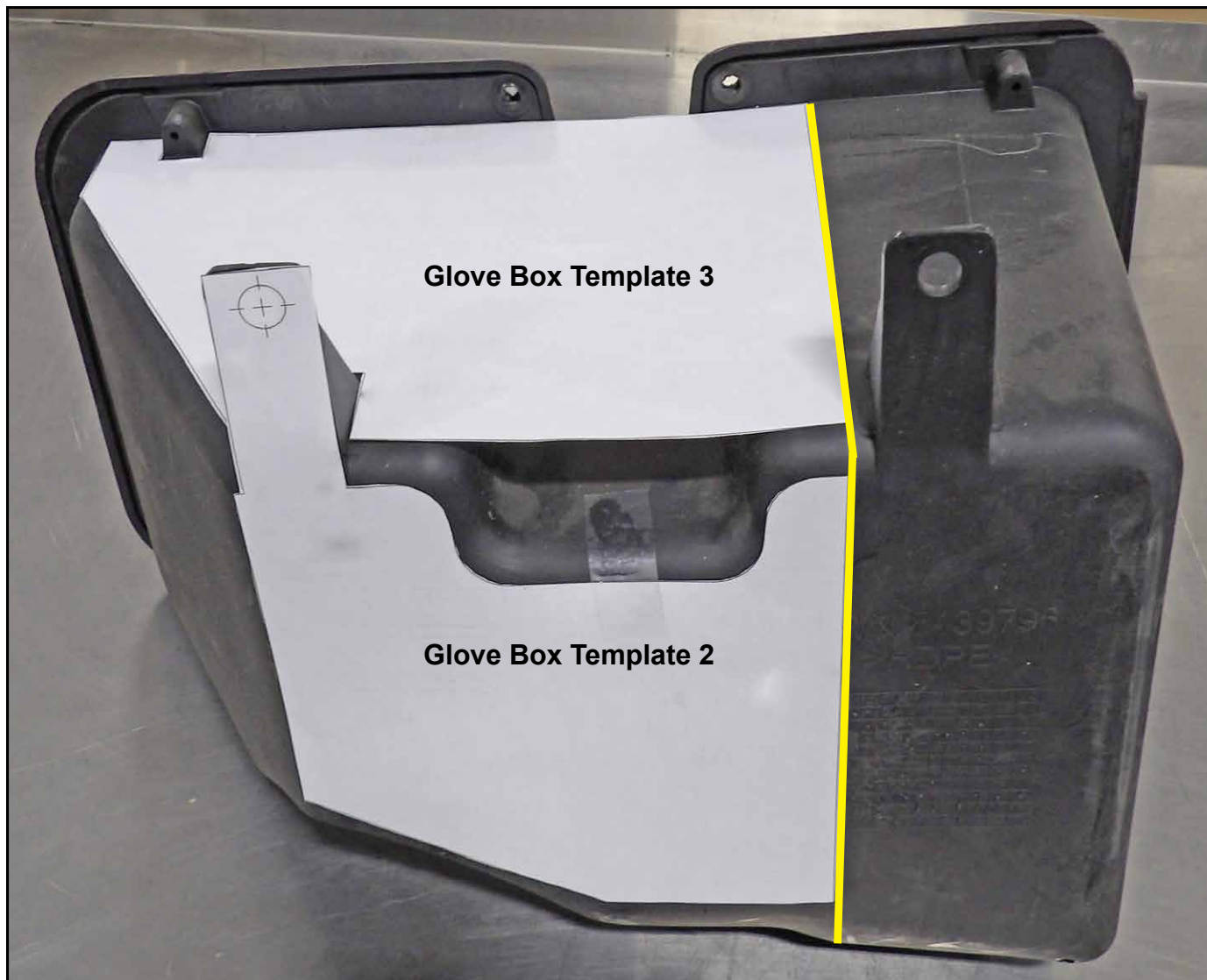

- Tape Template 1 into position.
- Use a straight edge and marker to make lines as shown.
- Remove Templates and cut away material; see following page for what Glove Box should look like after cutting.

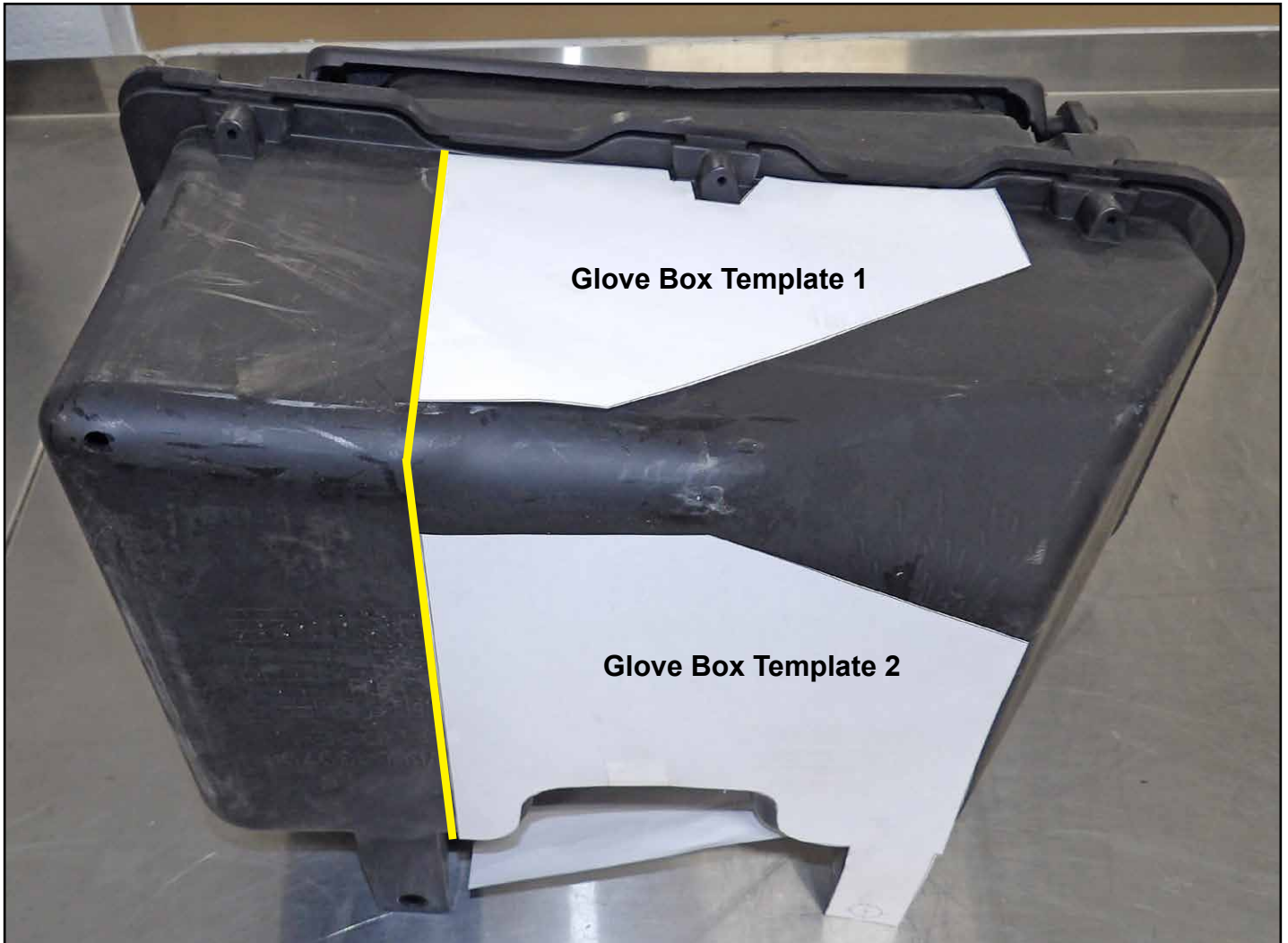



- Install Glove Box Plate to Glove Box with hardware shown.



- Install Adapters into Hose Plate.

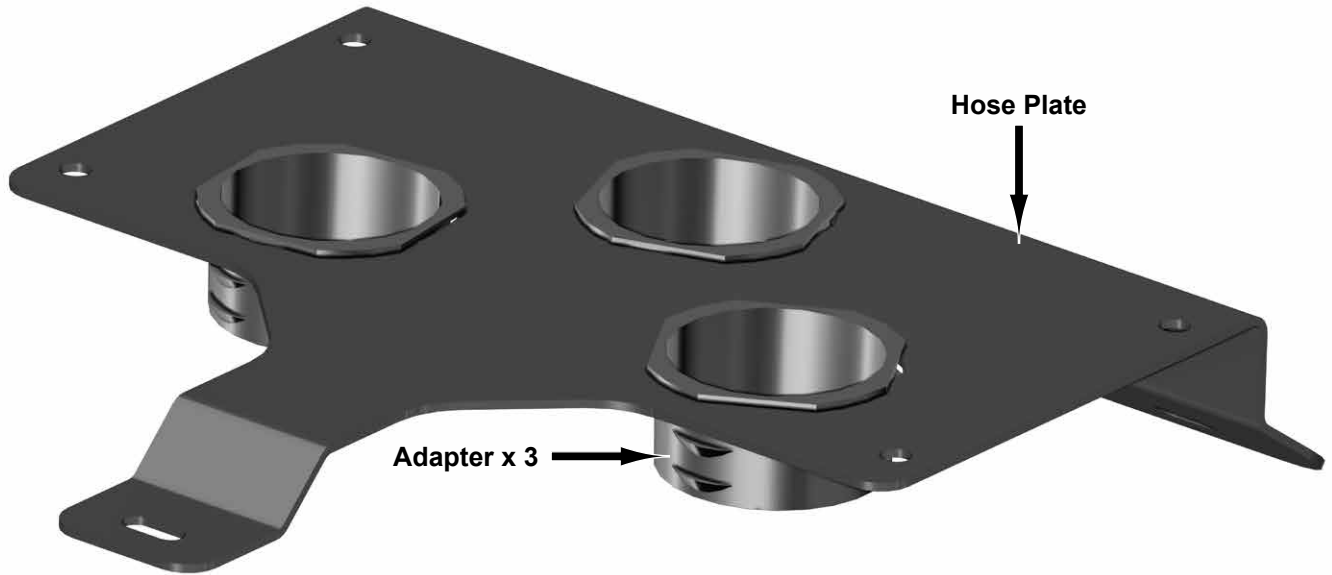

- Install Hose Plate to Blower with hardware shown; tighten.

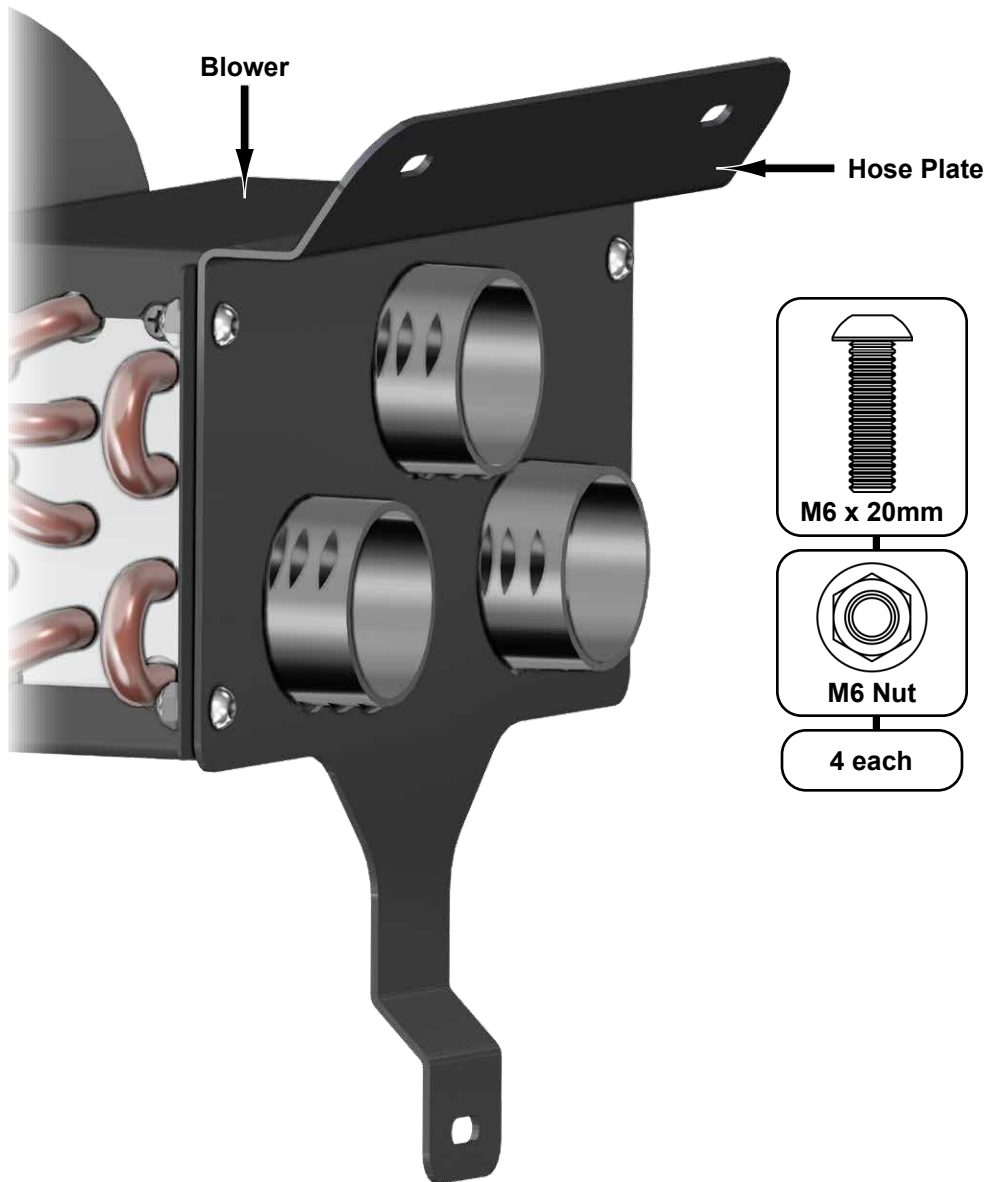



- Separate Knob and install to Control Plate.



Control Plate →

- Separate Vents and install to Control Plate.



Plumbing

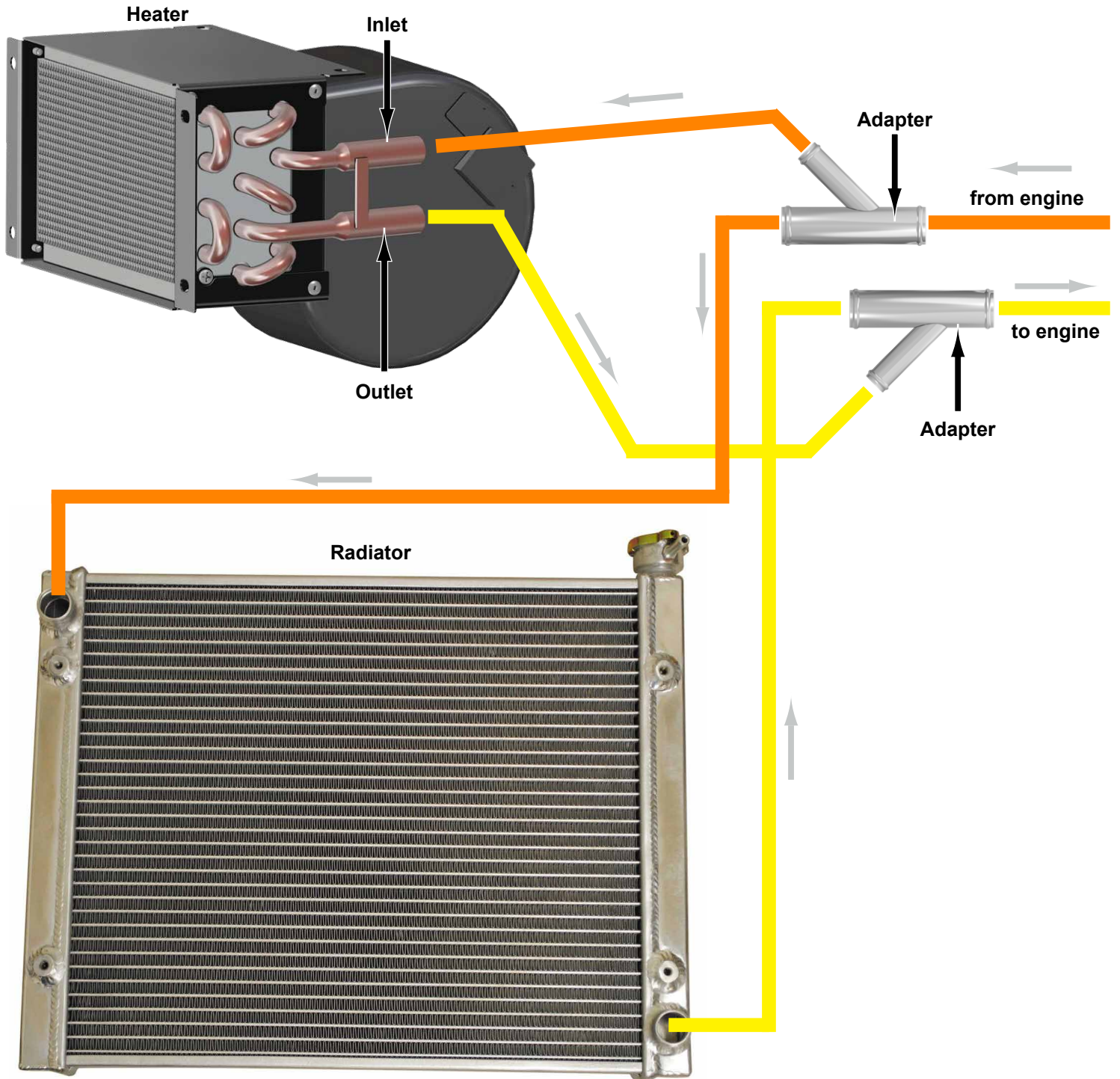

- Cut Tubing to lengths shown and install to Valve. Secure with Clamps.
- Install Elbow as shown.

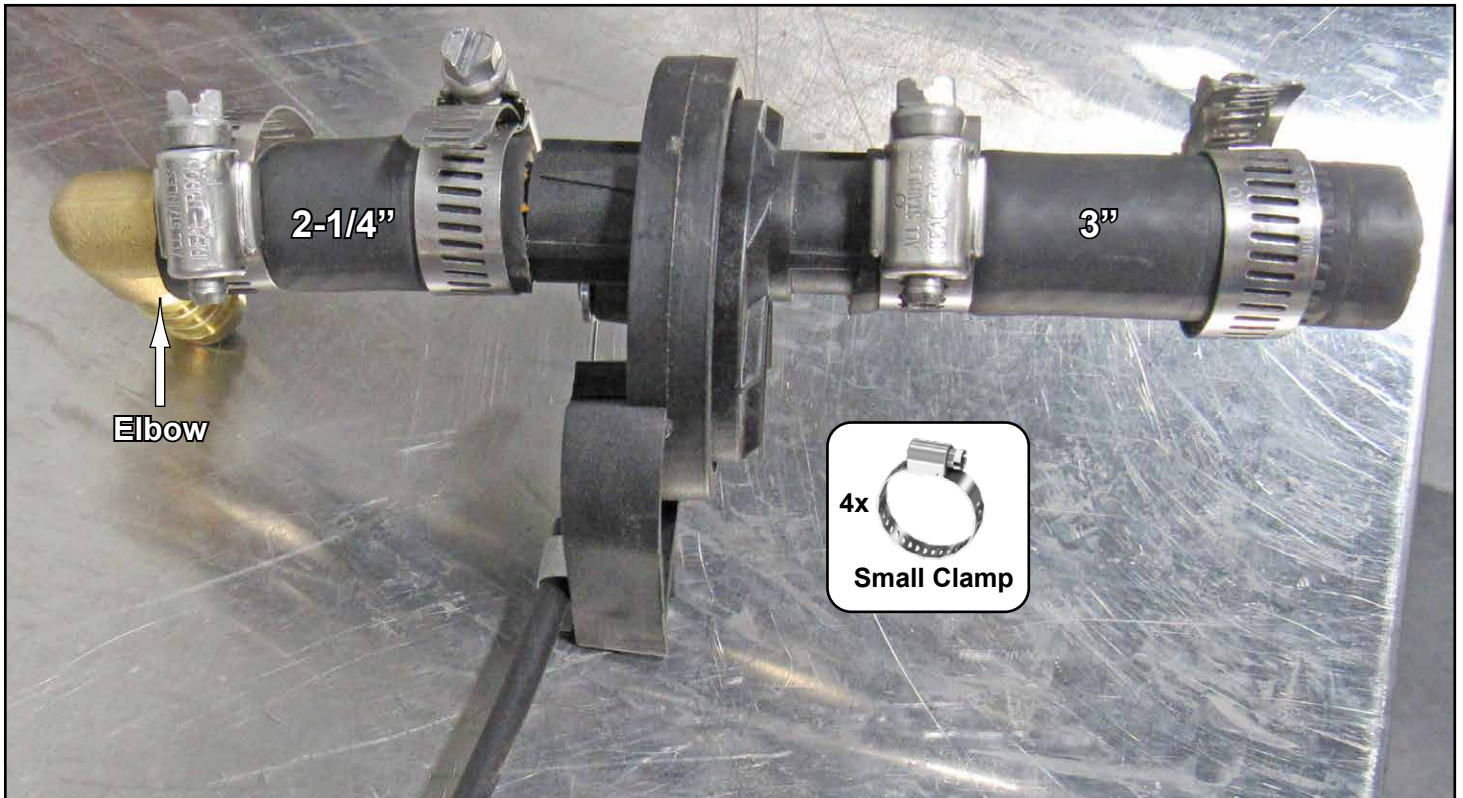

- Cut Ducting to lengths shown and install to Vents.
- Install Y-Fitting to Ducting.
- Secure Ducting with Wire Ties.



- Place Vents onto Upper Dash. Vents should be in general area as shown below.
- Mark locations for Vents and cut (2) Ø2-1/2" holes.

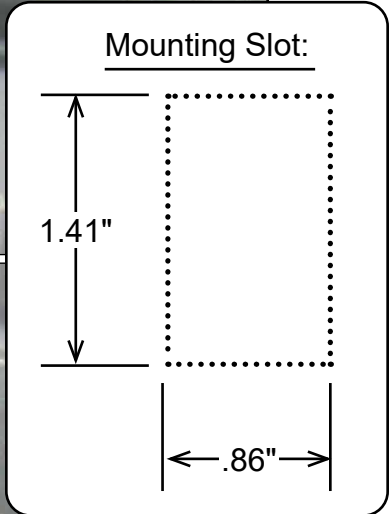
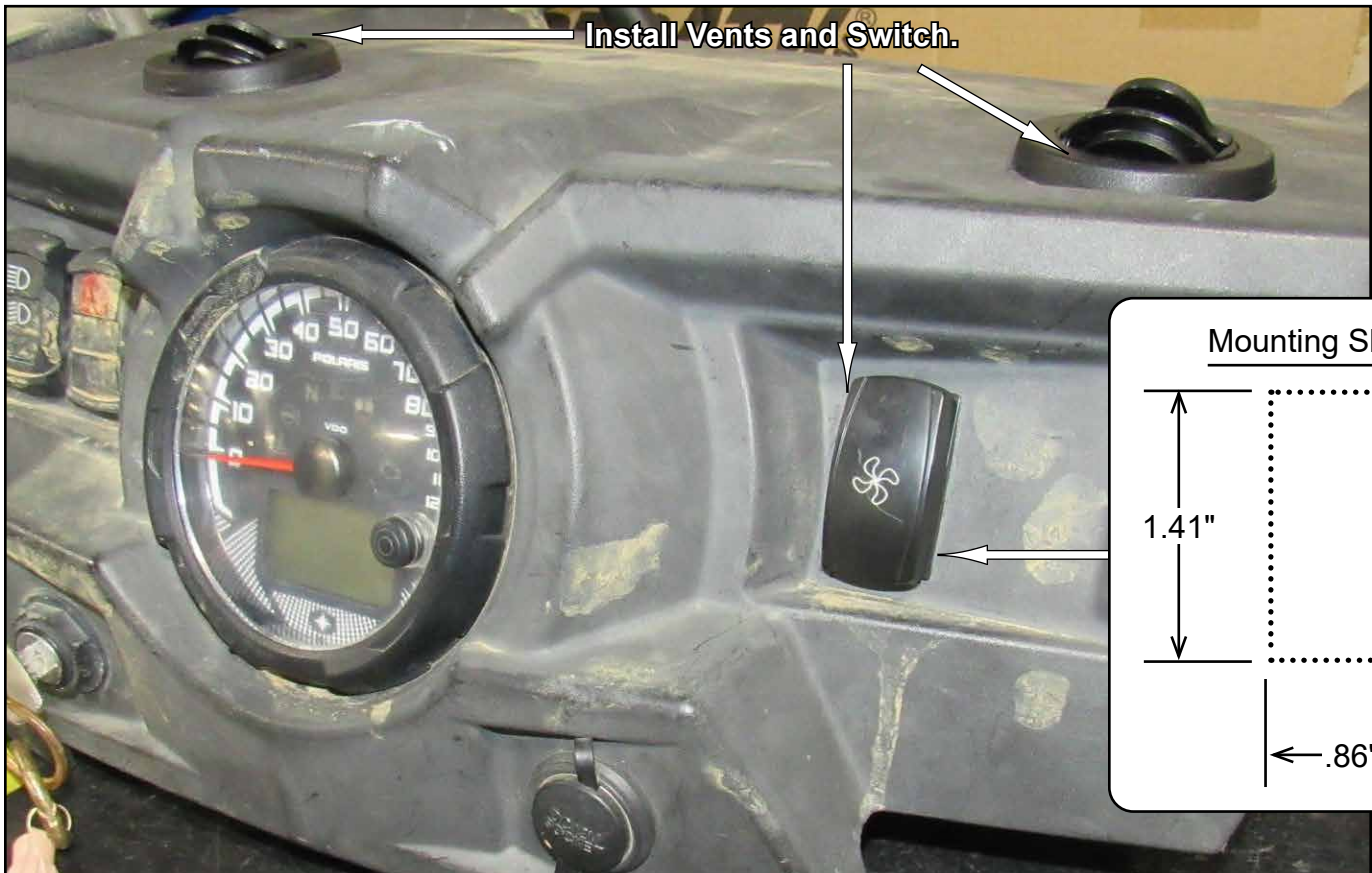

- Secure Hose Plate to Frame with hardware shown; tighten.

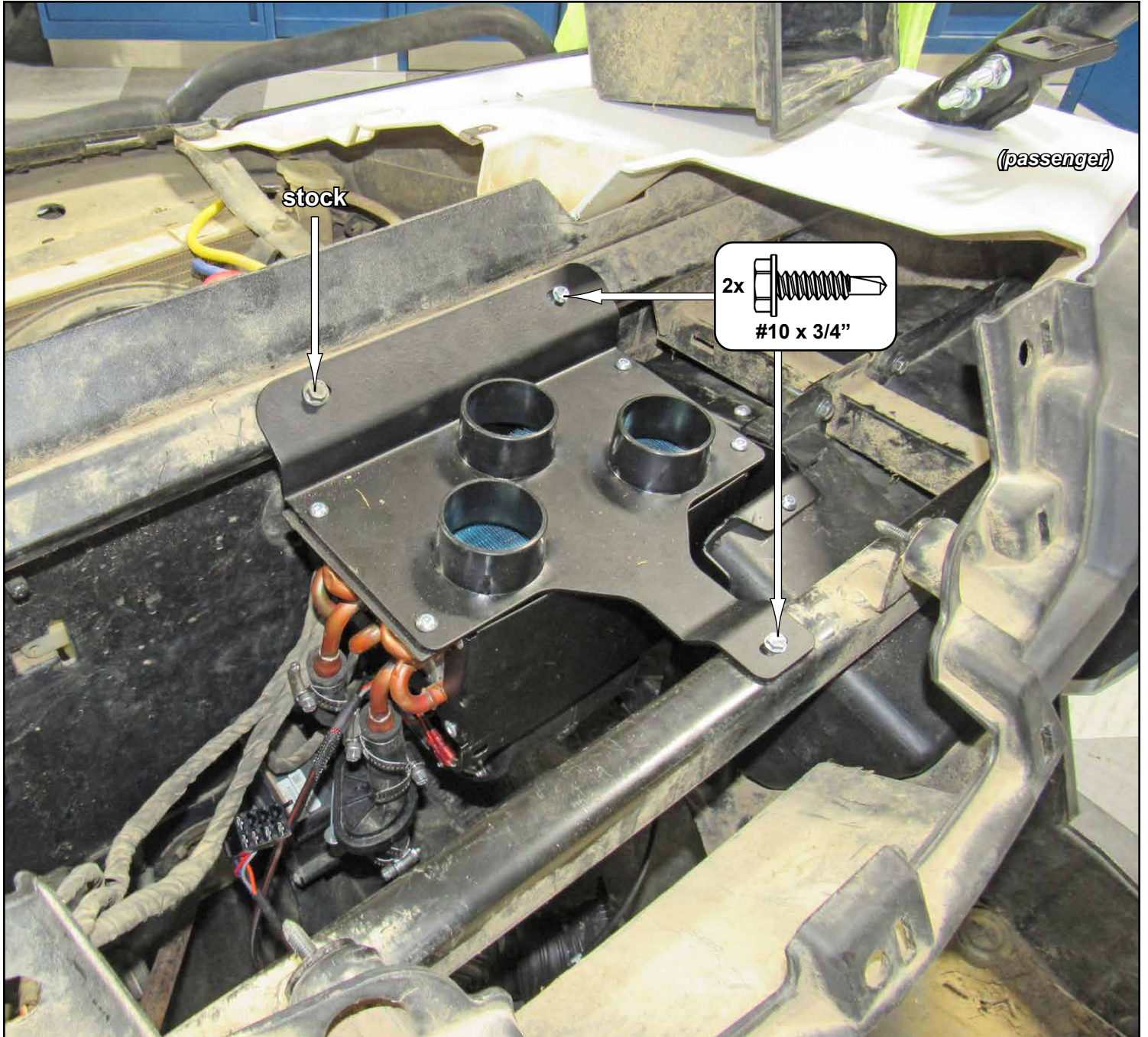

If a harness is attached to Blower, remove and discard it before attaching provided Blower Harness.

- Connect Blower Harness to Blower.

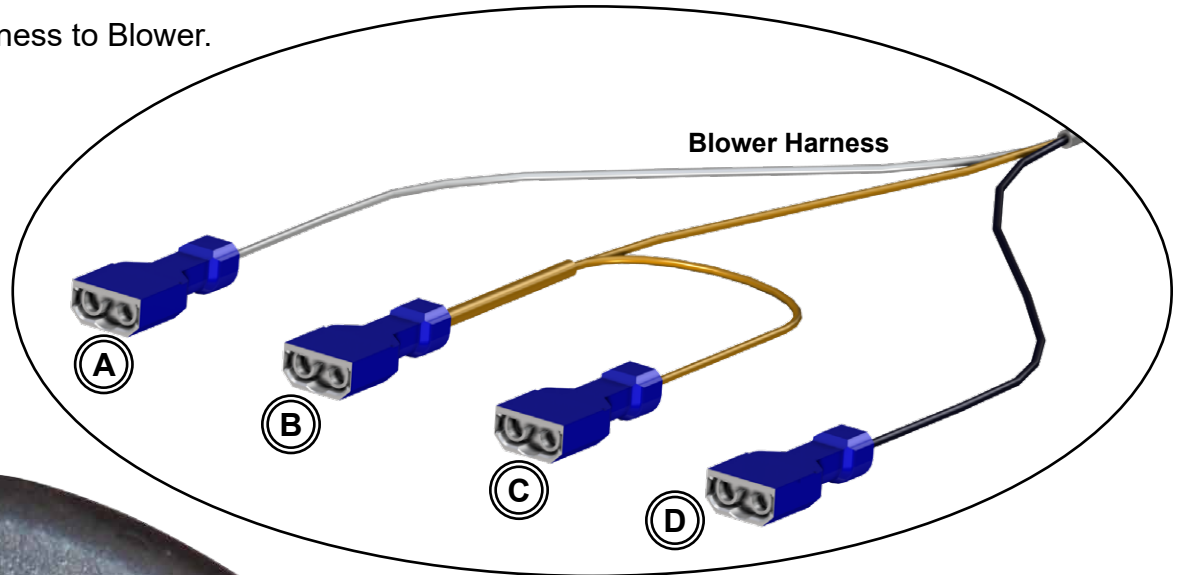

- Install Control Plate and Back Plate to Lower Dash with hardware shown; tighten.

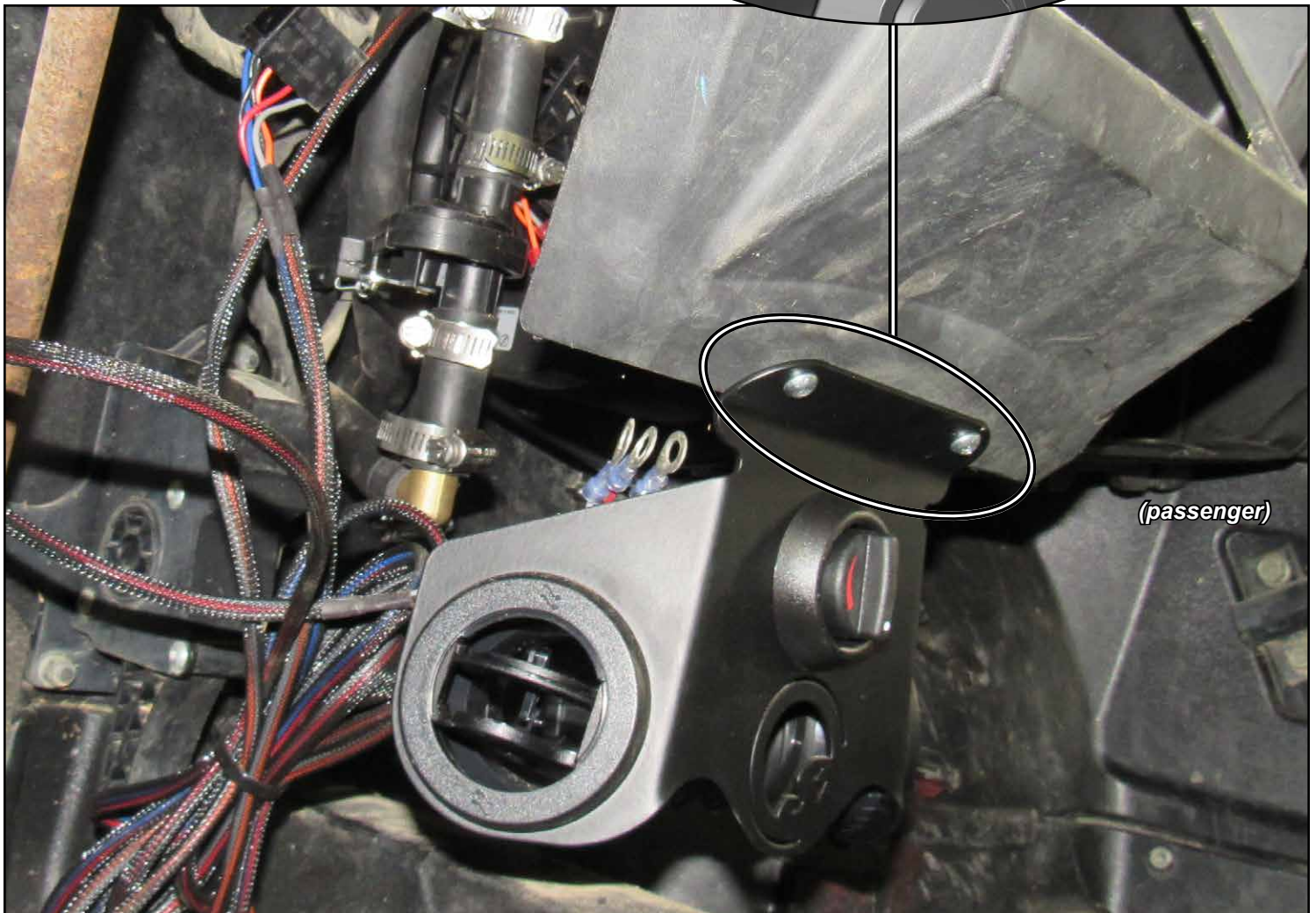
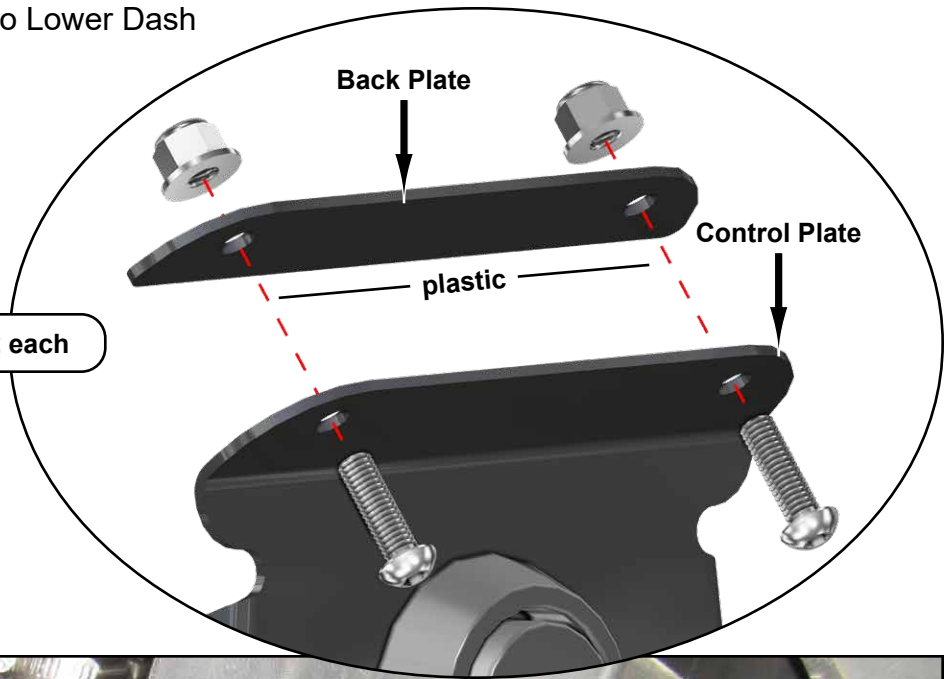
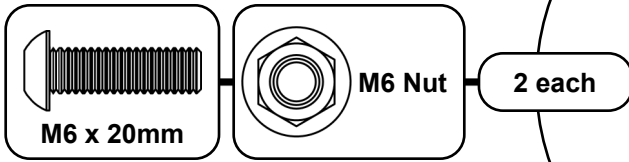

- Connect Power Harness to stock ACC Power Supply.
- Connect opposite end to corresponding plug on Blower Harness.

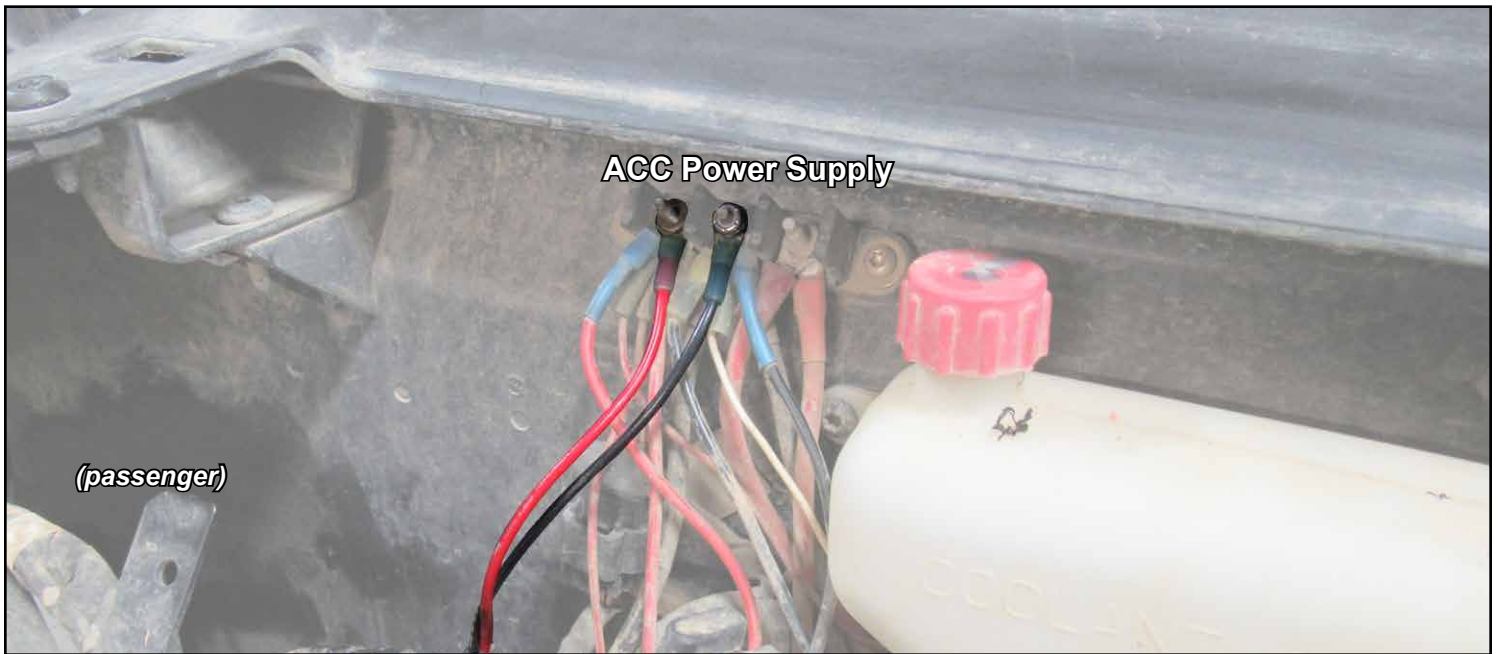

- Cut and install Ducting to Vents, Y-Fitting, and Adapters. Secure with Wire Ties.

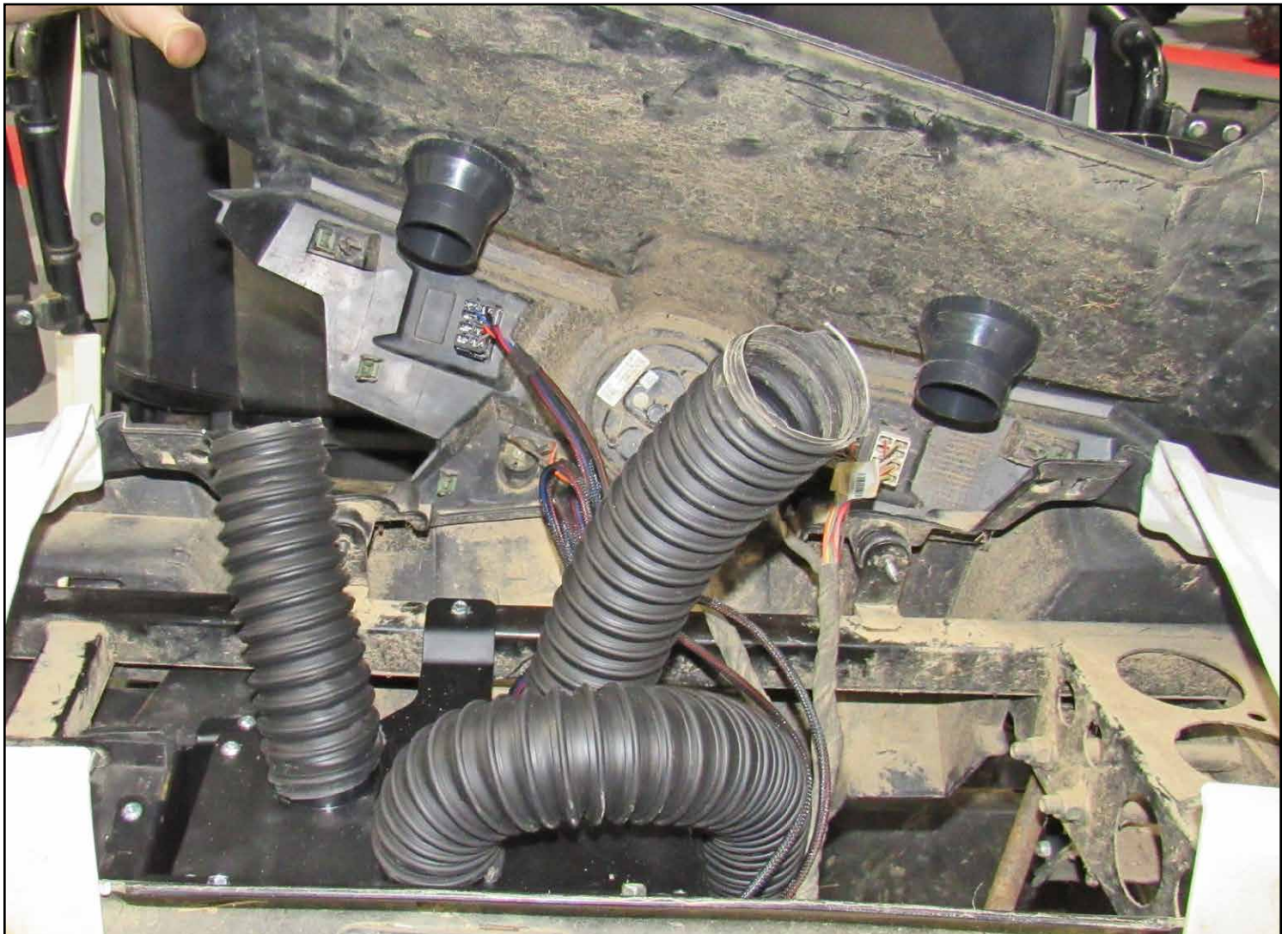

- Raise front of vehicle and place on jack stands.
- Remove Lower Radiator Hose and drain coolant.

To prevent stock Radiator Hoses from being cut short, use provided Adapters as templates.

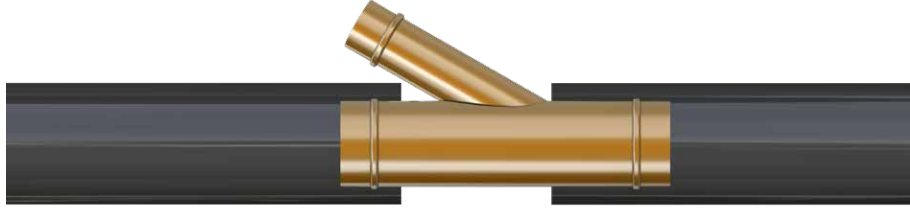

- Mark locations on stock Outlet Hose to be cut.
- Cut and secure to Adapter with provided Large Clamps.



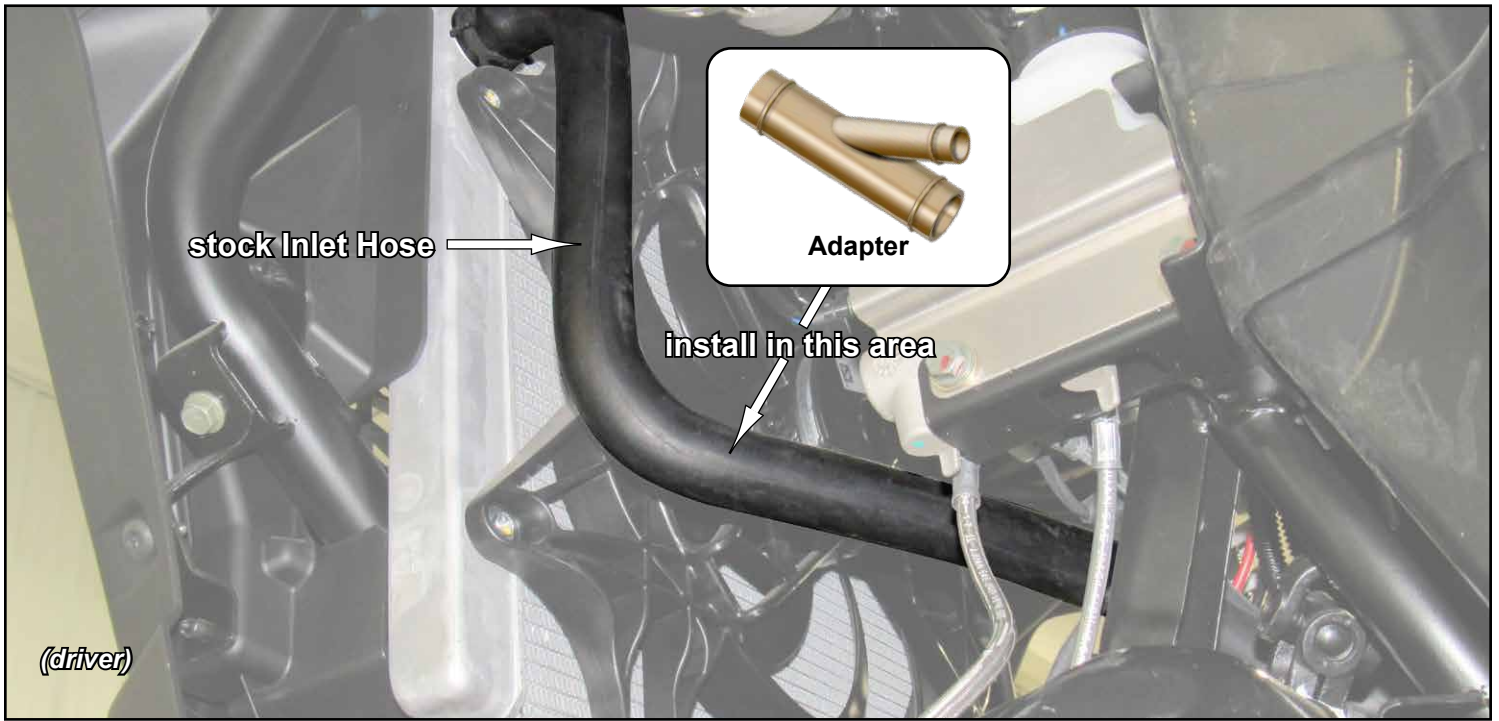

- Mark locations on stock Inlet Hose to be cut.
- Cut and secure to Adapter with provided Large Clamps.

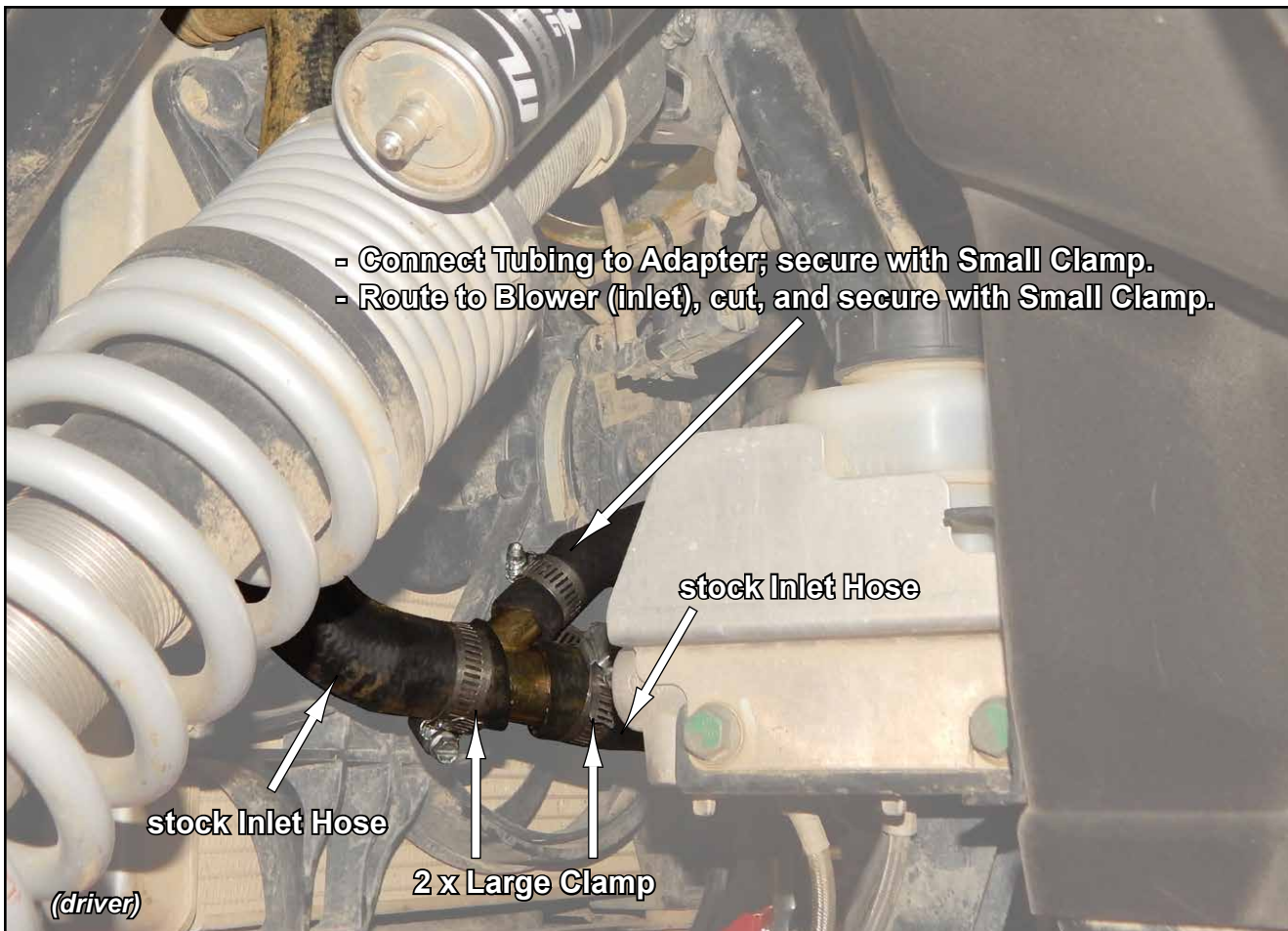

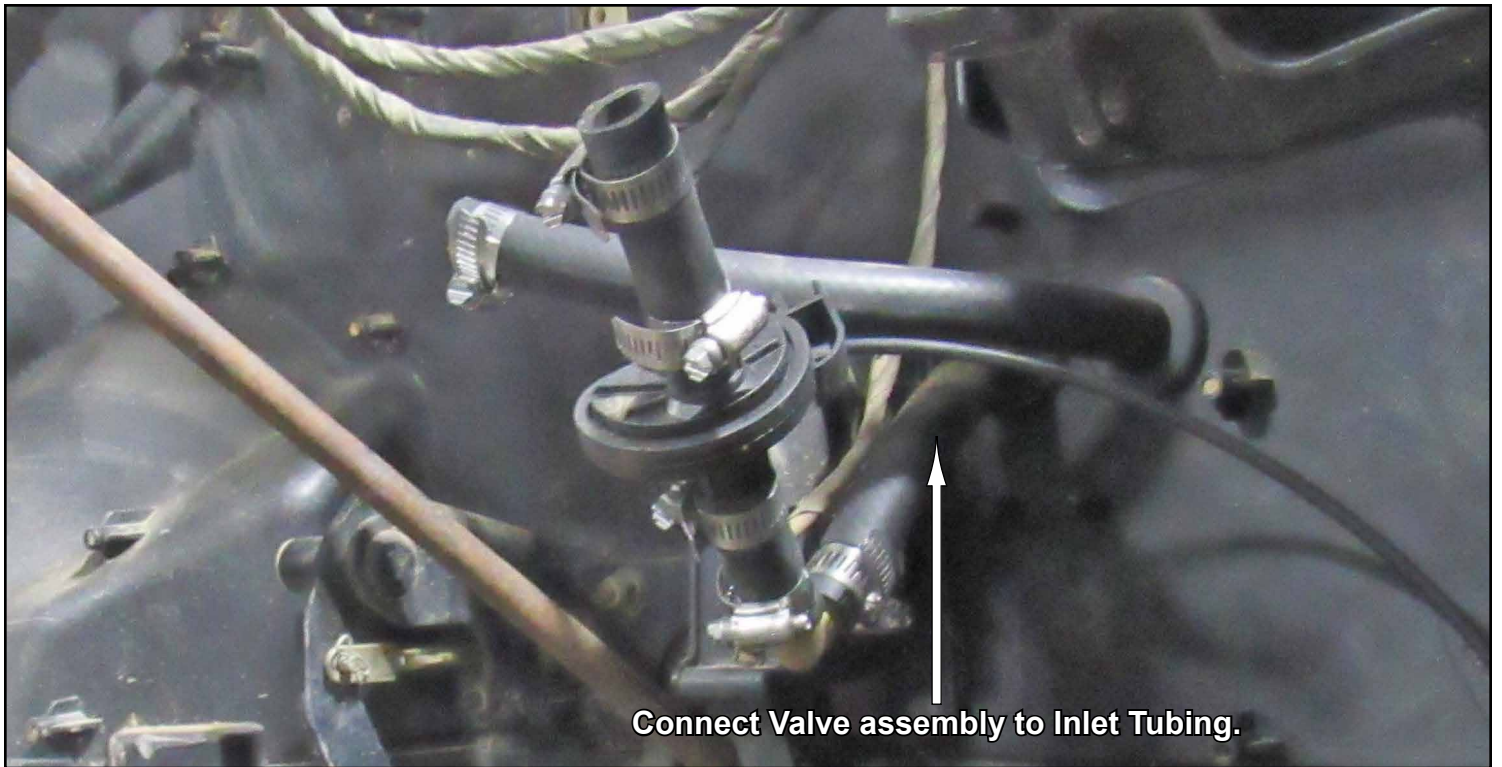

Connect Valve assembly to Inlet Tubing.

- Use Small Clamps to connect and secure Tubing to Blower.

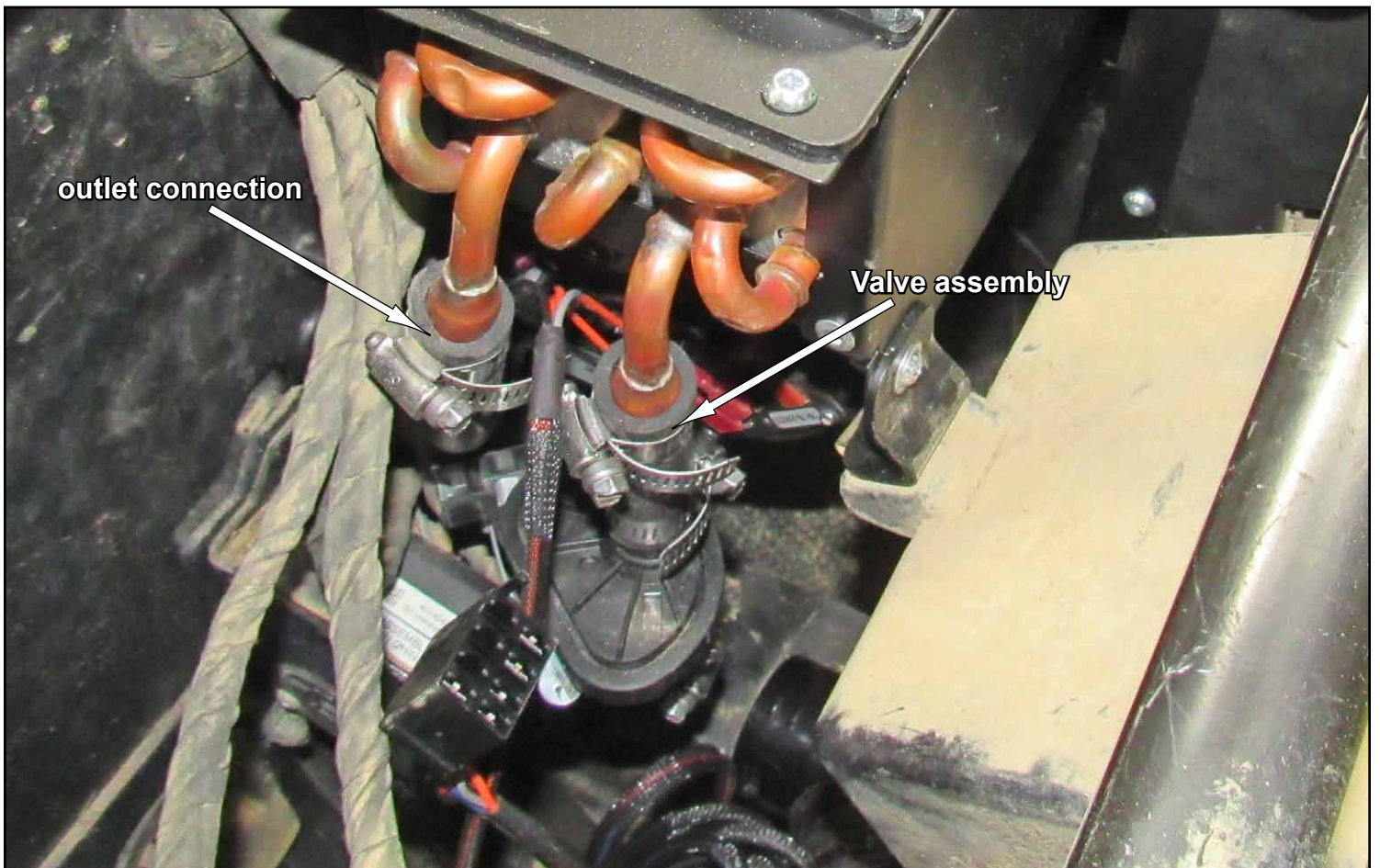

- Fill coolant level to manufacturers recommended setting.
- Start machine and run at 3000 RPM until engine is hot.
- Use Hose Pliers and pinch off Inlet Hose as shown below.

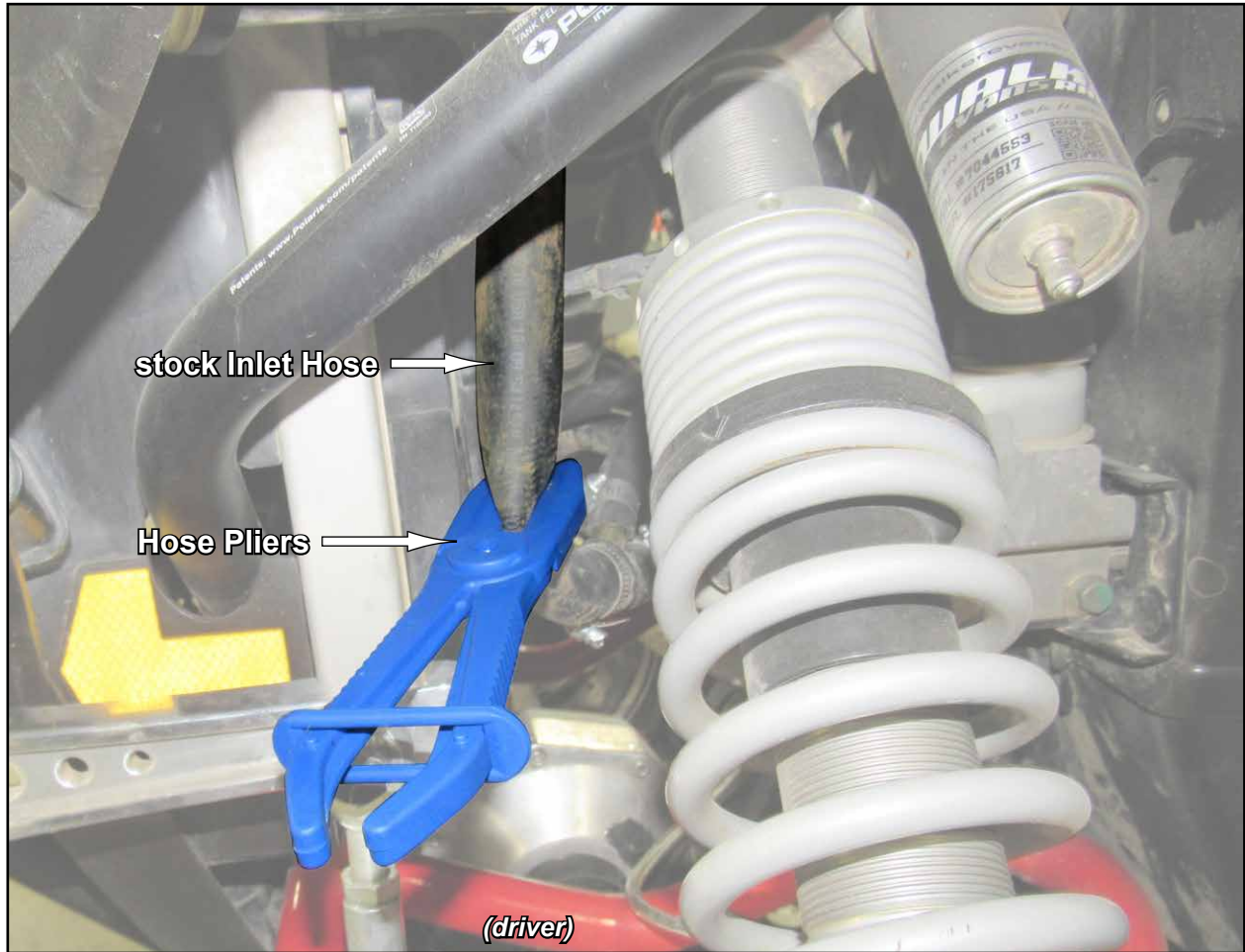

- Remove Hose Pliers after Radiator Fan turns ON.
- After Radiator Fan turns OFF, pinch Inlet Hose again and remove after Radiator Fan turns ON.
- Turn machine off and let engine completely cool; may take several hours.
- Check Coolant Level in Radiator and Reservoir; adjust as needed.
- Start machine and repeat "pinch" steps again.