



- ▲ BE SURE TO READ ALL INSTRUCTIONS AND ILLUSTRATIONS BEFORE STARTING.
- ▲ DO NOT DISCARD PACKAGING UNTIL PRODUCT HAS BEEN SUCCESSFULLY INSTALLED.
- ▲ MAKE SURE THE MODEL ON THE INSTRUCTION SHEET MATCHES YOUR VEHICLE.



## IMPORTANT

Assault Industries radius rods are developed for closed course race applications only, use outside of that environment is not recommended. Before each drive, inspect, clean and lubricate heim joints; Inspect and re-torque all nuts and bolts as needed. Improperly torqued nuts and bolts can lead to serious damage or worse! Read instructions thoroughly prior to installation. Installation should be performed by a qualified professional.

### FROM THE TOOLBOX

- ▲ SOCKET/RATCHET SET
- ▲ TAPE MEASURE
- ▲ RED THREAD LOCKER
- ▲ GRINDER/METAL FILE
- ▲ TOUCH-UP PAINT
- ▲ JACK/CHOCKS/  
STANDS

# TRAILING ARM MODIFICATION

The XP trailing arm will require minor modification to properly fit the lower radius rod. Before installing the rods, use a file or grinder to remove approximately 1/4" of material from the outer edge as shown on **Fig.1**. This will allow clearance for the lower rods to fully articulate without touching the trailing arms. Failure to do so could cause damage to the trailing arm and/or rods. Then, Repeat the steps for the remaining radius rods. When everything is aligned, use thread locker to tighten the bolts and jam nuts!

**You Must Remove 1/4" Of Trailing Arm For Installation Of New Radius Rods. See Below.**



**Note:** There are two rod lengths - 2 long for the bottom and 2 short for the top. Once adjusted, hand tighten the nuts on the heims. It is easier to tighten the jam nuts on all rods at the last step. It is important that the lengths (heim center to heim center) are the same as OEM. It is recommended that thread exposure on both ends of the rod is the same. It is also important to keep the heims parallel to each other.

## INSTALLATION PROCESS

1. Properly secure the vehicle with wheel chocks and loosen the radius rod bolts. Removing rear wheels is not required, but will make the job easier.
  2. Raise the rear of the vehicle until the wheels are off the ground. Add jack stands for safety.
  3. Remove one OEM radius rod at a time from the vehicle. Use the OEM rod to adjust the length of the Assault Industries radius rod that will replace it on the vehicle.
  4. (**UPPER RODS**) After adjusting the Assault Industries radius rod to the correct length, install the tall misalignment spacers on both sides of the inside heims of the straight rods. (**LOWER RODS**) The Delrin bushing slips over the fixed spacer and install on both sides of the lower rods on the inside.
- ▲ For 2013-2017 non-turbo and 2016 turbo use the spindle spacer with tapered head on the outer heims that mount on the wheel hub. For 2017+ vehicles use the standard (flat) spindle spacer there should be 8.
- ▲ When installing the Assault Industries radius rods, use the opposite side as a reference on how to position the misalignment spacers.

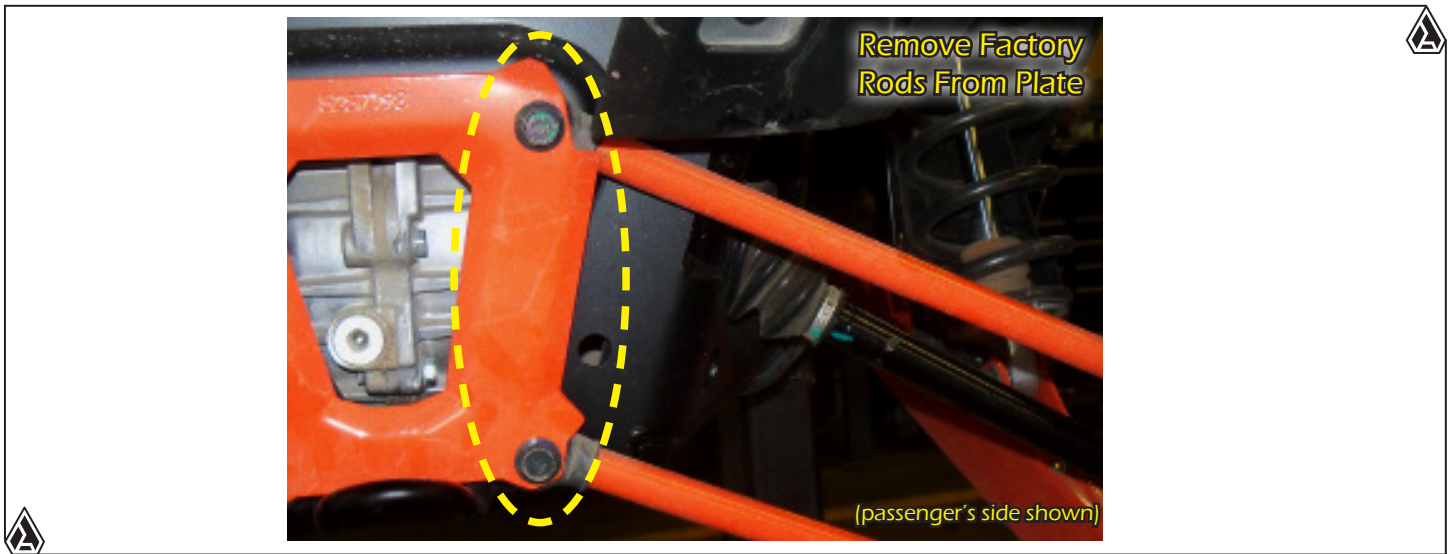

FIG.2A

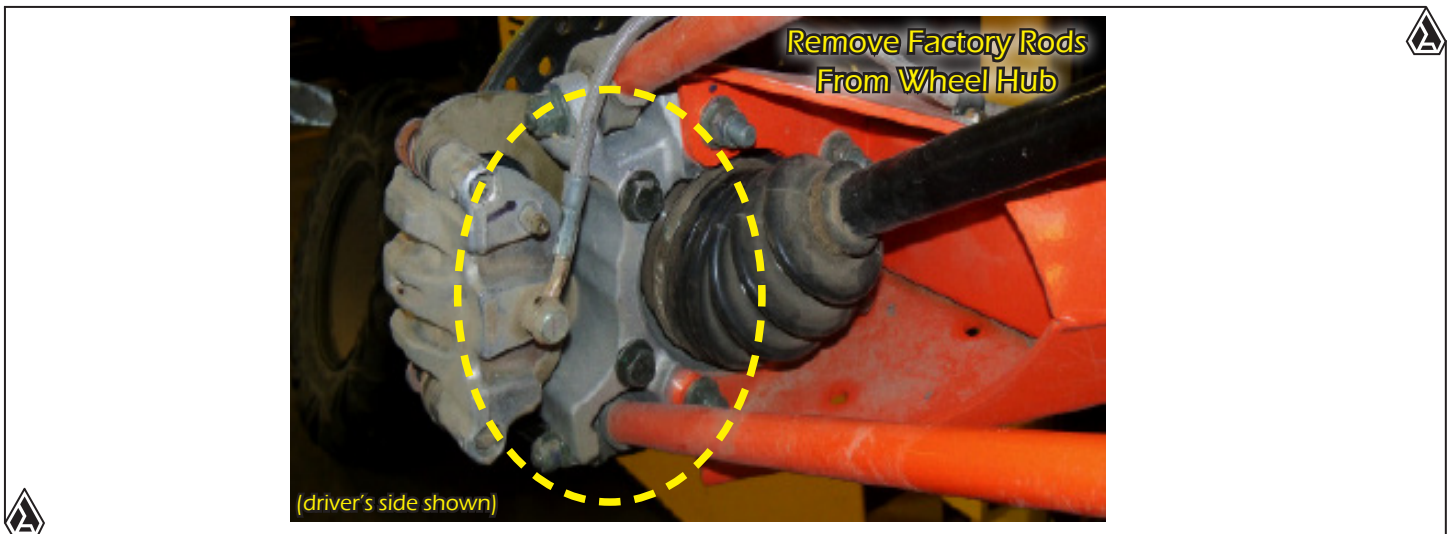

FIG.2B

2. Remove Factory Radius Rods and Brace Plate from Frame, **Fig.2A**, then remove Factory Radius Rods from Wheel Hub as shown in **Fig.2B**.



FIG.3

3. Measure eye-to-eye distances on Factory Radius Rods and transfer dimensions to your new Rods. **Fig.3**.

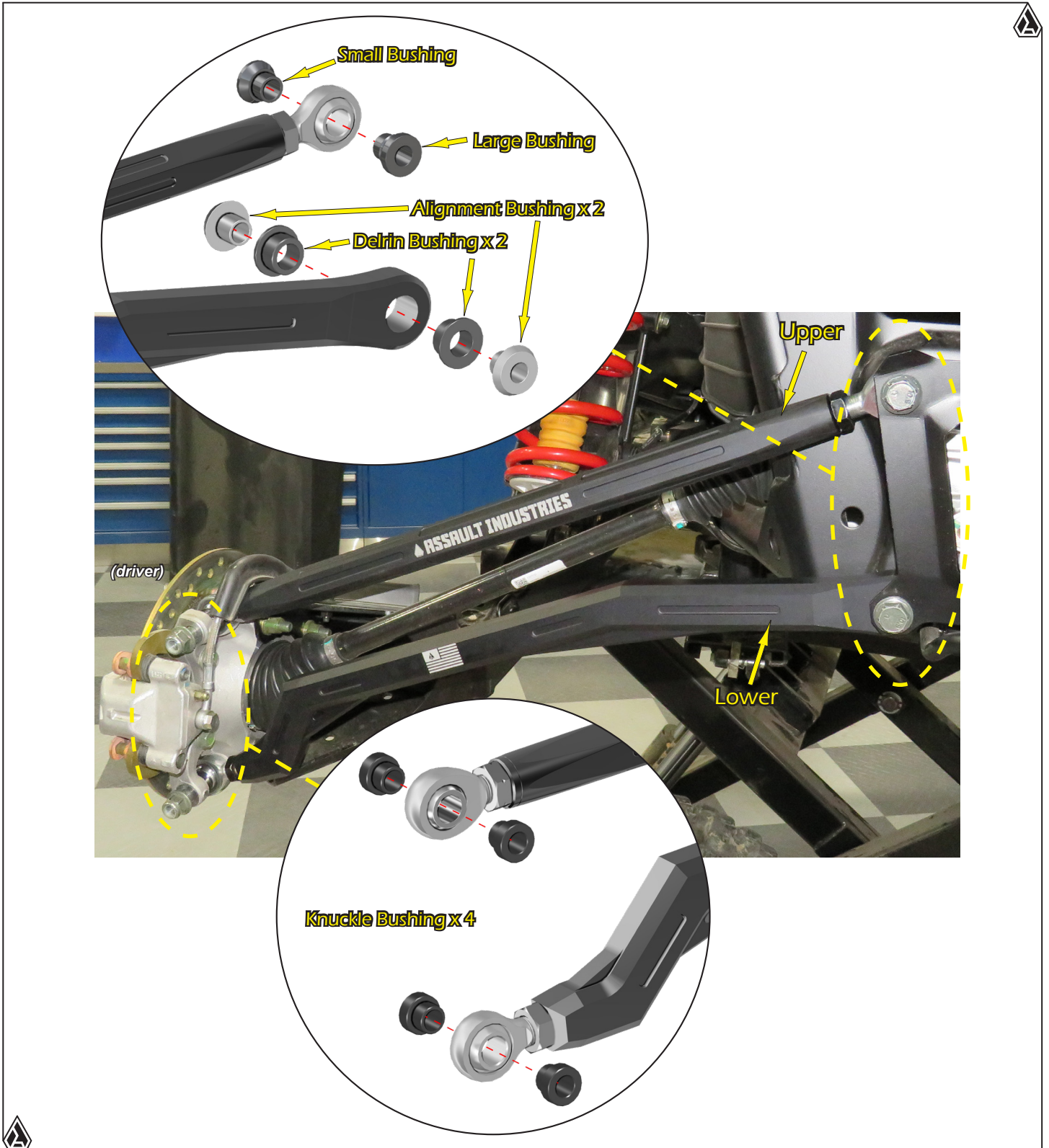
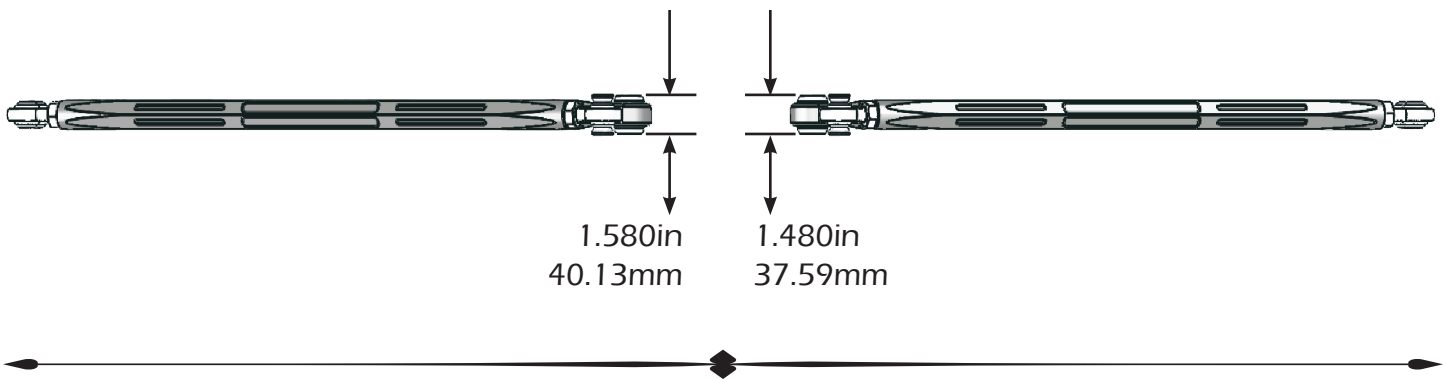

FIG.4

4. Install Bushings per Fig.4 to the New Rods and the install the New Rods, Upper & Lower and tighten to secure. Repeat for opposite side. See Fig.4.

(Top View Outer)

(Top View Inner)



**MAKE SURE THAT ALL BOLTS AND NUTS ARE TORQUED TO FACTORY SPECIFICATIONS AND ARE SECURE. PLEASE CONTACT ASSUALT INDUSTRIES FOR QUESTIONS REGARDING SPECIFICATIONS OR ANY OTHER QUESTIONS YOU MAY HAVE. THANKS!**

#### Liability Statement

Assault Industries® products are designed to best fit user's ATV/UTV under stock conditions. Adding, modifying, or fabricating any factory or aftermarket parts will void any warranty provided by Assault Industries® and is not recommended. Assault Industries® products could interfere with other aftermarket accessories. If user has aftermarket products on machine, contact Assault Industries® to verify that they will work together.

Although Assault Industries® has thousands of satisfied customers, user should be aware that installing lift kits, long travel, or suspension kits, tires, etc. will change the ride of machine and may increase maintenance and part wear. Operating any off-road machine while, or after, consuming alcohol and/or drugs increases risk of bodily harm or death. No warranty or representation is made as to this product's ability to protect user from severe injury or death. Assault Industries® urges operators and occupants to wear a helmet and appropriate riding gear at all times.

By purchasing and installing Assault Industries® products, user agrees that should damages occur, Assault Industries® will not be held responsible for loss of time, use, labor fees, replacement parts, or freight charges. Assault Industries®, nor any 3rd party, will not be held responsible for any direct, indirect, incidental, special, or consequential damages that result from any product purchased from Assault Industries®. The total liability of seller to user for all damages, losses, and causes of action, if any, shall not exceed the total purchase price paid for the product that gave rise to the claim.

Assault Industries® will warranty only parts provided by Assault Industries®. Any damage or problems with OEM housings, bearings, seals, or other manufacturers' products will not be covered by Assault Industries®. Assault Industries® parts and products are not warranted if item was not installed properly, misused, or modified.

Installing, adding, modifying, or fabricating any factory or aftermarket product to your ATV/UTV may violate certain local, state, and federal laws. Be advised that laws vary depending on town, city, county, state, etc. Use of certain products on public streets, roads, or highways may be in violation law. The Buyer is solely and exclusively legally and personally responsible for any violation of the law by the installation or use of the product. You must abide by all local, state, and federal laws, including but not limited to vehicle safety, traffic laws, and ordinances. It is your responsibility to know the laws and how they apply to you.

The Buyer is responsible to fully understand the capability and limitations of his/her vehicle according to manufacturer specifications, warnings and instructions and agrees to hold Assault Industries® harmless from any damage resulting from failure to adhere to such specifications, warnings and/ or instructions. The Buyer is also responsible to obey all applicable federal, state, and local laws and ordinances when operating his/her vehicle while using this product, and the Buyer agrees to hold Assault Industries® harmless from any violation thereof.

#### LEAVE US FEEDBACK

Visit [Assaultind.com](http://Assaultind.com) and leave a review of your product purchase. We appreciate your opinion.....even if you're wrong! 😊



#### NEED ADDITIONAL HELP?

Check out our YouTube channel  
Call us : (714) 799-6711  
Monday - Friday: 8am-5pm  
Email: [sales@assaultind.com](mailto:sales@assaultind.com)

**ASSAULT INDUSTRIES // 2753 MICHIGAN ROAD // MADISON, IN 47250**

**ASSAULTIND.COM**