



Adjustable Clutch Kit: CKSDPO912-S2
Fits: 2024 Polaris Expedition
Models Riding: 0-3000ft Elevation
Models Using: 30"-36" Tires

Be Sure To Read ALL Instructions and Illustrations Before Beginning.
This installation requires special tools. If you are unsure of yourself, please
contact a Qualified Technician to do the installation.

KIT ITEMS INCLUDED:

- Drive Spring -Orange
- Driven Spring - Gold
- Weights - (included in kit)
- Stage-2 Helix
- Shim Kit - (included in kit)
- Decals
- Installation Instructions



Adjustable Weights

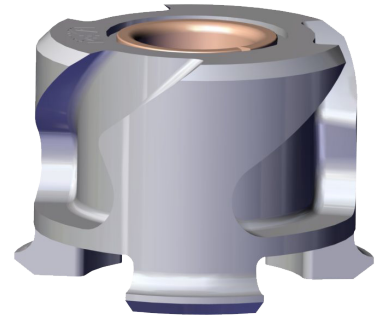

Stage II Helix

TOOLS NEEDED:

- Floor jack & safety stands
- Drive clutch puller - (Call 855.743.3427 for proper tool for this kit)
- Driven clutch compression tool - (Call 855.743.3427 for proper tool for this kit)
- Polaris Belt Removal Tool
- 3/8" metric socket set & 7/8" socket 1/2"
- 15mm socket • Torx set • Allen set

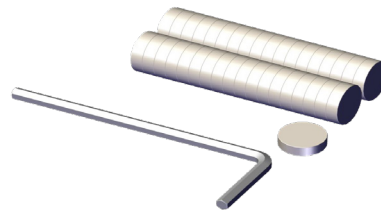

Weight Magnets & Tool



Orange "Drive" Clutch Spring

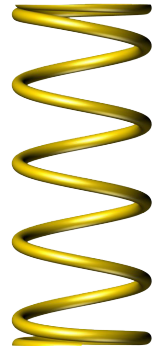

Gold "Driven" Clutch Spring

NOTE:

- **Make sure the year & model on instruction sheet matches the year & model of your vehicle.**
- **Do Not attempt this install w/o proper tools or damage to clutches & injury could occur.**
- **Do Not attempt this install if you are not qualified. Injury could occur.**
- **Inspect Drive/Driven clutch faces before you install kit.**

• • • Installation • • •

Note: Before installation, you will need to lift the machine up onto jack stands or equivalent to relieve the pressure off the shock springs to move them.

1. With the transmission placed in PARK, remove the Left Rear Shock Guard (3 Torx #25 screws if you have one), and lower shock bolt, and move Shock out of the way. See **Fig.1**.

(Note: Removing the Lower Rear Shock Bolt may make it easier to remove Clutch Cover, but not required)



Fig.1

2. Next, loosen the clamps holding exit air tube on clutch cover and upper end and remove out of the way. See **Fig.2** & **Fig.3**.

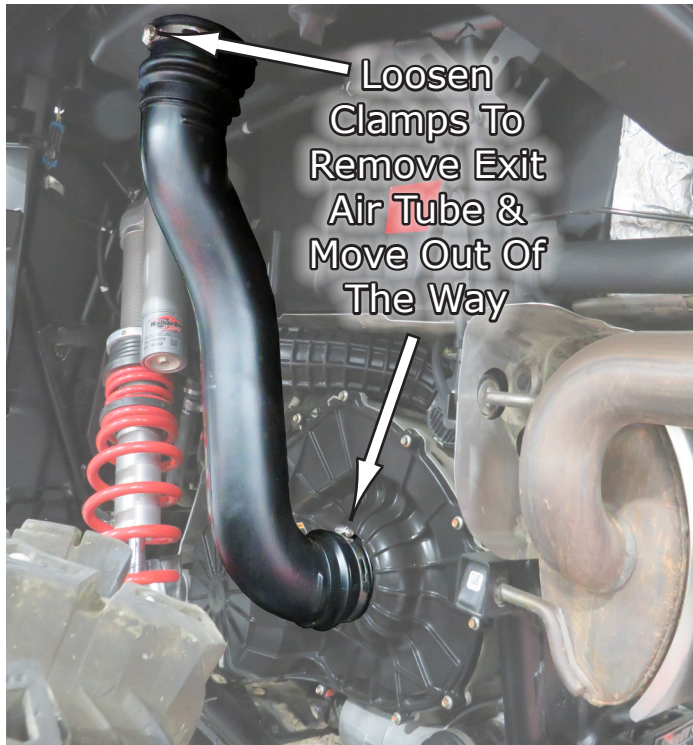

Fig.2



Fig.3

3. Now remove the **(14) Bolts** holding the Clutch Cover on using a **5mm socket**. See **Fig.3**. Then remove the cover pulling straight out. See **Fig.4**.

4. After removing the Cover, enter the Belt Tool from your vehicle in hole close to the clutch center bolt (turning clockwise) which loosens the clutch so you can take the Stock Belt off. See **Fig.5**.

NOTE: Before Taking Belt Off, take notes or pics of which direction the printing on the outside of the belt is facing, and the depth of the belt in the sheaves before taking it off. You will need to put it back on the with the printing facing the same direction and with the same belt depth as it is now!



Fig.4



Fig.5

5. Now take the Belt off and set aside. **Fig.6.** shows belt removed.



Fig.6

• • • **DRIVEN CLUTCH REMOVAL** • • •

6. Next, remove Secondary or “**Driven Clutch**” bolt (M8), washers and shims.

Count Washers and Shims for re-assembly as adding or removing Shims will affect Clutch/Belt alignment and shifting!

7. Remove the bolt, Washer and Shims, see **Fig.7a**, and remove Driven Clutch. See **Fig.7b**.



Fig.7a

8. **Fig.7b.** shows unit removed.

Now you can separate the two halves by slightly twisting and pulling them apart.



Fig.7b

9. After you remove the top, now make a mark underneath where the two pieces join so you can align it up in the right position during reassembly. See **Fig.8**.

At This Point You Should Clean, Wipe and Blow Dust From Driven Clutch Assembly Before Modifying!



Fig.8

10. Set driven clutch sheave assembly onto your compression tool, Helix Down. See **Fig.9**.



Fig.9

11. Now, compress down using your compression tool relieving spring pressure. See **Fig.10**.

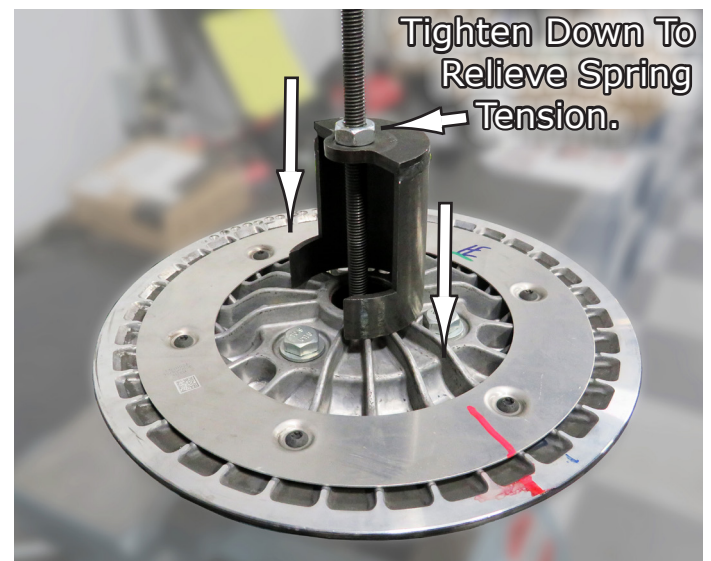

Fig.10

12. Next, remove the (3) top Hex Head Helix bolts (16mm). See **Fig.11**.



Fig.11

13. After bolts have been removed, back off compression tool to remove plate off of Spring. See **Fig.12**.



Fig.12

••••• **SPECIAL INSTRUCTIONS FOR YOUR MODEL NUMBER OPTIONS** •••••

NOTE: Up to this step, the installation process is the same for all versions and options that you can choose from when ordering your kit. The next section will show a table of different combinations or choices you can make when ordering this kit. It shows which of the Springs you will use in the Driven Clutch and how many of the magnet weights you will need to install in the Flyweights, all provided in your kit. You will just look for the combination of choices you chose when ordering your kit and apply what the table says to your specific choices. You will look for the Terrain, what Tire Size and Elevation you chose. The sections after the table are examples of the Part number with various options chosen showing what Spring(s) are being used as well as the "P" number which determines the number of magnet weights you will insert in each weight seat location of the Flyweight.

ALSO NOTE: When referencing the chart, even though you may be using your Factory and not a new colored spring, you will still need to install the New Helix from your kit for Step 14.

OPTIONS TABLE

Terrain	Tire Size	Elevation	Weight Set-up			Drive Spring	Driven Spring	Helix	Top RPM	Result
			Hole1	Hole2	Hole3					
Trail	30"-32"	0-3000'	3	2	2	Orange	Stock	36-40	7750	Balanced
Trail	30"-32"	0-3000'	1	1	1	Orange	Stock	36-40	8100	Performance
Trail	30"-32"	0-3000'	4	4	3	Orange	Stock	36-40	7250	Comfort
Trail	33"-35"	0-3000'	3	2	2	Orange	Gold	36-40	7750	Balanced
Trail	33"-35"	0-3000'	1	1	1	Orange	Gold	36-40	8100	Performance
Trail	33"-35"	0-3000'	4	4	3	Orange	Gold	36-40	7250	Comfort
Mud	30"-32"	0-3000'	1	2	1	Orange	Gold	36-40	8100	Performance
Mud	33" 36"	0 3000'	0	1	1	Orange	Gold	36-40	8100	Performance

Listed RPM reference is prior to full shift out ~60mph

If machine is tuned or otherwise making more power than stock, it may be necessary to add weight to bring rpm back down.

Recommended to start with 1 additional magnet in hole 2.

Do not exceed 4 magnets per hole.

Recommended Settings for Elevation

3000'-6000'	Subtract 1 magnet from hole 2
6000'+	Subtract 1 magnet from hole 3

Recommended Settings for Gear Reduction

Actual Tire Size	Gear Reduction	Corresponding Set-up Tire Size
33"-35"	15-30%	30"-32"
36"-40"	15%	33"-35"
36"-40"	30-45%	30"-32"
40"-44"	30%	33"-35"
40"-44"	45-70%	30"-32"

Take your actual tires size that you have in the "Actual Tire" column, match the % of reduction in the middle section that you have, then substitute the tire size in the "Corresponding" column in the same row as your actual tire size to make your choices for correct set-up above.

Examples of choices and how it affects the Springs and Magnet Weights used in your kit.

FOR MODEL: CKSDP0912-S2: Using 33"-35" Tires @ 0-3k ft. Elevation - Trail Ride - Top RPM:7750

- 14.** Remove Factory Spring and Helix and replace with your **New Helix** and **"Gold" Spring** provided in your kit. Be sure to put on the **Top Hat Washer** from your Factory Spring. See **Fig.13-14**.

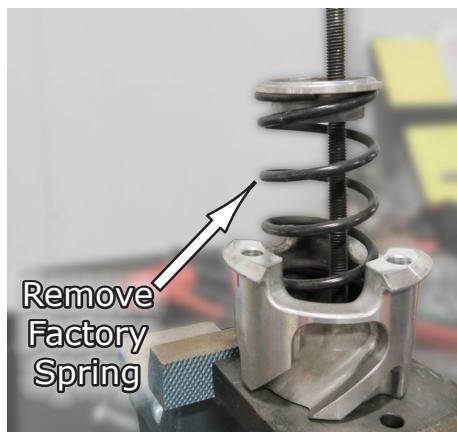

Fig.13



Fig.14

*** Your Specific Weight Set-up Number For This Kit (Gold Spring) is: P322T.**

Write down the number associated with the color spring you will use as you will need it to reference how to load your weights with the magnets in the following steps.

FOR MODEL: CKSDP0912-S2: Using 33"-35" Tires @ 0-3k ft. Elevation - Trail Ride - Top RPM:8100

14. Remove Factory Spring and Helix and replace with your **New Helix** and "**Gold**" **Spring** provided in your kit. Be sure to put on the **Top Hat Washer** from your Factory Spring. See **Fig.13-14**.

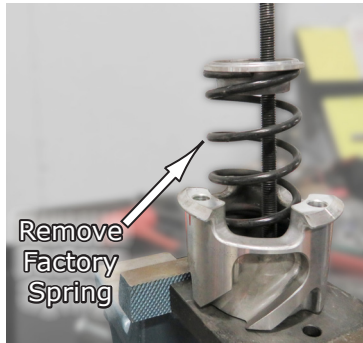

Fig.13



Fig.14



* Your Specific Weight Set-up Number For This Kit (Gold Spring) is: **P111T**.

Write down the number associated with the color spring you will use as you will need it to reference how to load your weights with the magnets in the following steps.

FOR MODEL: CKSDP0912-S2: Using 33"-35" Tires @ 0-3k ft. Elevation - Trail Ride - Top RPM:7250

14. Remove Factory Spring and Helix and replace with your **New Helix** and "**Gold**" **Spring** provided in your kit. Be sure to put on the **Top Hat Washer** from your Factory Spring. See **Fig.13-14**.

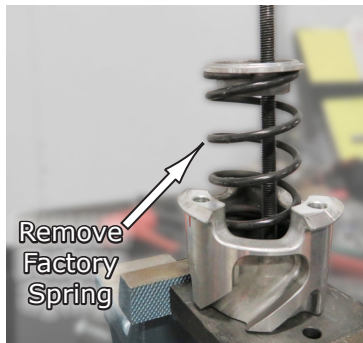
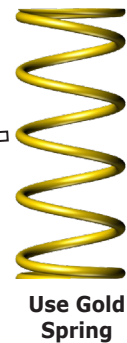

Fig.13



Fig.14



* Your Specific Weight Set-up Number For This Kit (Gold Spring) is: **P443T**.

Write down the number associated with the color spring you will use as you will need it to reference how to load your weights with the magnets in the following steps.

FOR MODEL: CKSDP0912-S2: Using 30"-32" Tires @ 0-3k ft. Elevation - Mud Ride - Top RPM:8100

14. Remove Factory Spring and Helix and replace with your **New Helix** and "**Gold**" **Spring** provided in your kit. Be sure to put on the **Top Hat Washer** from your Factory Spring. See **Fig.13-14**.

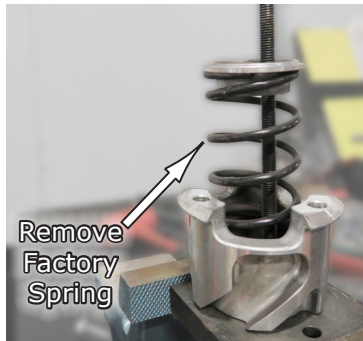

Fig.13



Fig.14



* Your Specific Weight Set-up Number For This Kit (Gold Spring) is: **P121T**.

Write down the number associated with the color spring you will use as you will need it to reference how to load your weights with the magnets in the following steps.

FOR MODEL: CKSDP0912-S2: Using 33"-36" Tires @ 0-3k ft. Elevation - Mud Ride - Top RPM:8100

- 14.** Remove Factory Spring and Helix and replace with your **New Helix** and "**Gold**" **Spring** provided in your kit. Be sure to put on the **Top Hat Washer** from your Factory Spring. See **Fig.13-14**.



Fig.13

Fig.14

* Your Specific Weight Set-up Number For This Kit (Gold Spring) is: **P011T**.

Write down the number associated with the color spring you will use as you will need it to reference how to load your weights with the magnets in the following steps.

- 15.** After inserting your new spring and Top Hat Washer, replace the top and align the markings you drew before separating previously. See **Fig.15**.



Fig.15

16. Now Compress the top down to compress the spring, and replace the three Hex Head Bolts **using Blue Loc-Tite**, and **torque to 63ft.lbs.** See **Fig.16**.

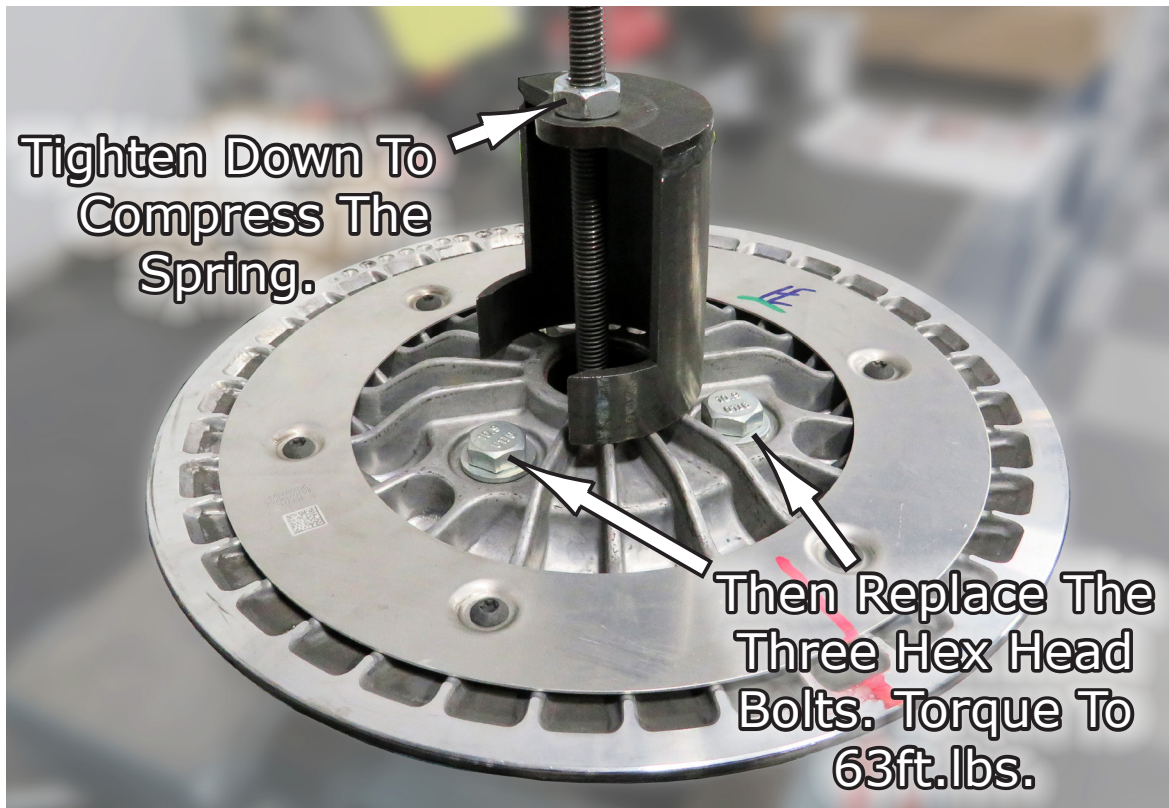

Fig.16

17. After tightening the bolts down, you can now replace the other sheave putting them back together, See **Fig.17**, ready to reinstall onto the machine. But we will do that ahead in another step. Right now we need to switch to the "**Drive or Primary Clutch**" for modifications.

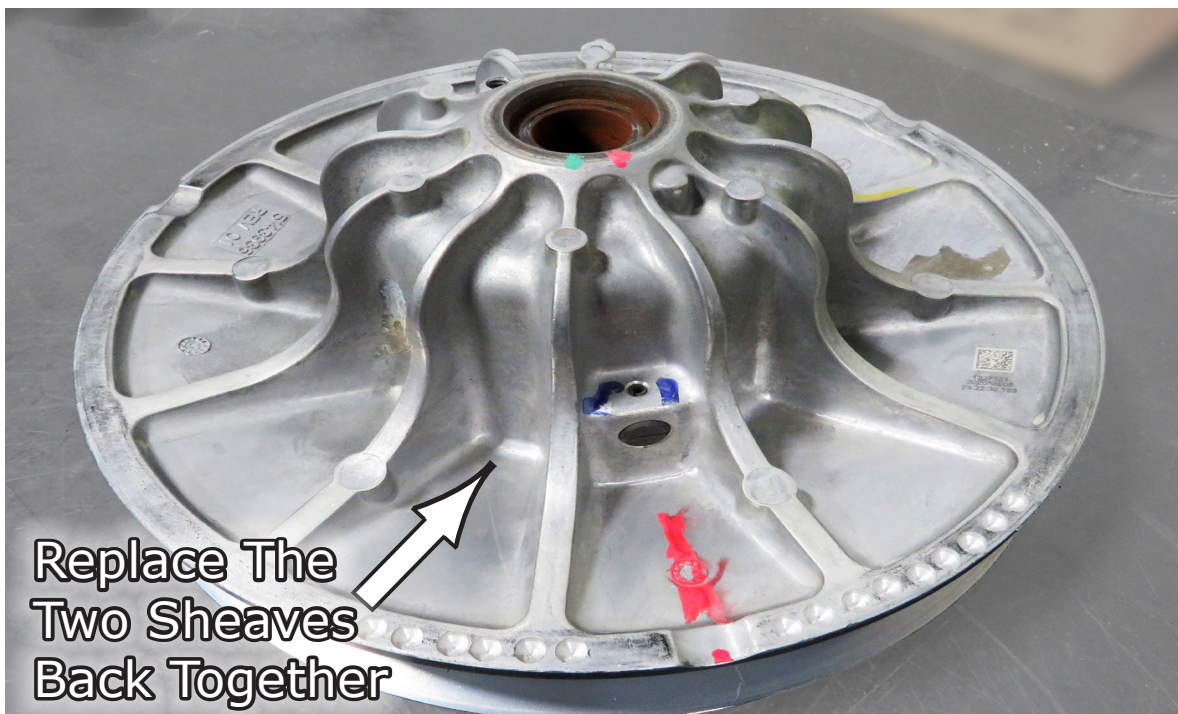

Fig.17

• • • DRIVE CLUTCH REMOVAL • • •

18. Now switch to the "Drive Clutch".

Before removing, mark the location of each sheave in line with each other so you can align them up when you reinstall them to assure proper alignment of the belt. See **Fig.18**.

19. Next, remove the center retaining bolt using a long extension and a Torx T60 socket. If tight, a breaker bar can be used while holding the clutch assembly still and in place. See **Fig.19a**.

Once bolt is removed, the outer movable sheave can be removed by rocking the sheave and pulling outward. Be careful not to drop clutch spacers if the primary shaft is removed. If outer drive sheave assembly will not come off clutch shaft, remove Drive Clutch using special required clutch puller & 7/8" socket, after removing primary shaft.

Remove Primary Clutch from the machine.

NOTE: If Special Puller Tool is required, hand thread remover tool to get started after removing outer Drive Clutch post, as OEM torque spec is 118ft.lbs., so clutch is on there tight. Mark an "X" on the spider to match "X" on cover for alignment and re-assembly. Watch for two washers that may fall when removing post. An O-ring holds two washers to the removable shaft.

NOTE: It might be a good thing to inspect bolts behind drive clutch at this point. If they are loose, add Loctite and torque to 7ft.lbs. See Fig.19b.

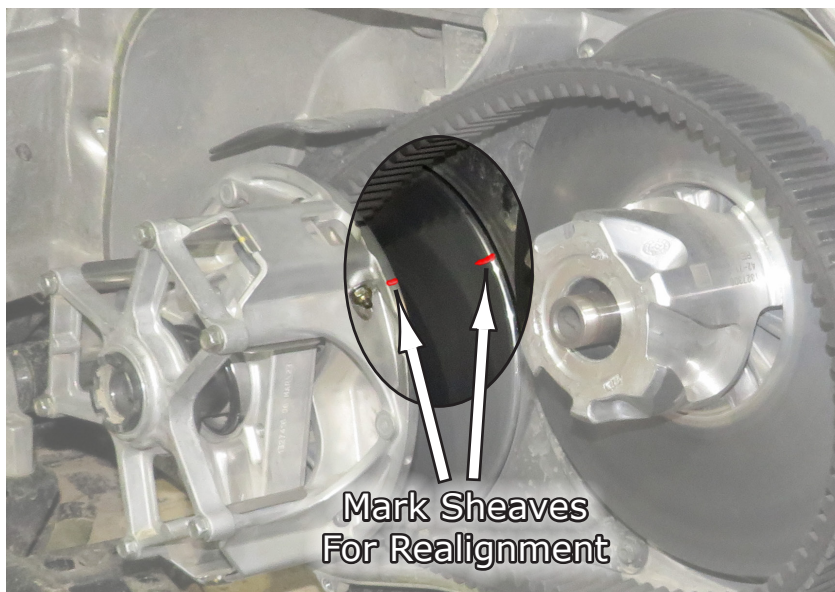

Fig.18

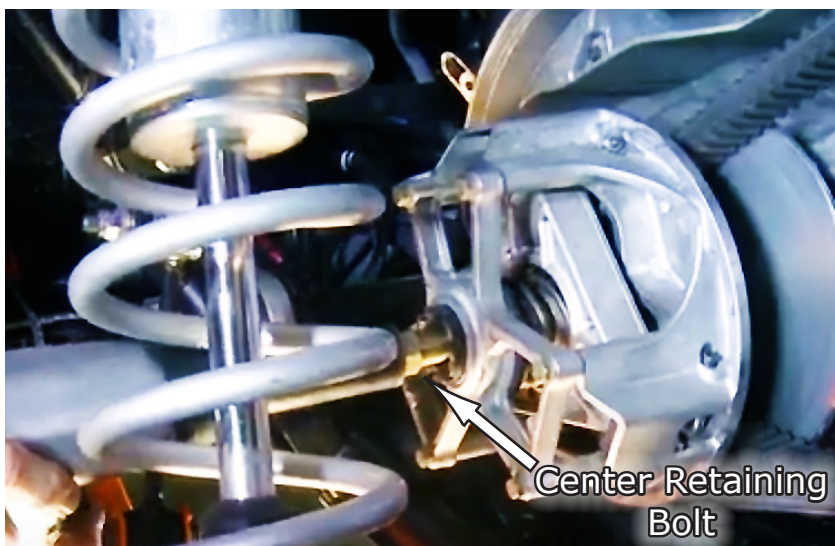

Fig.19

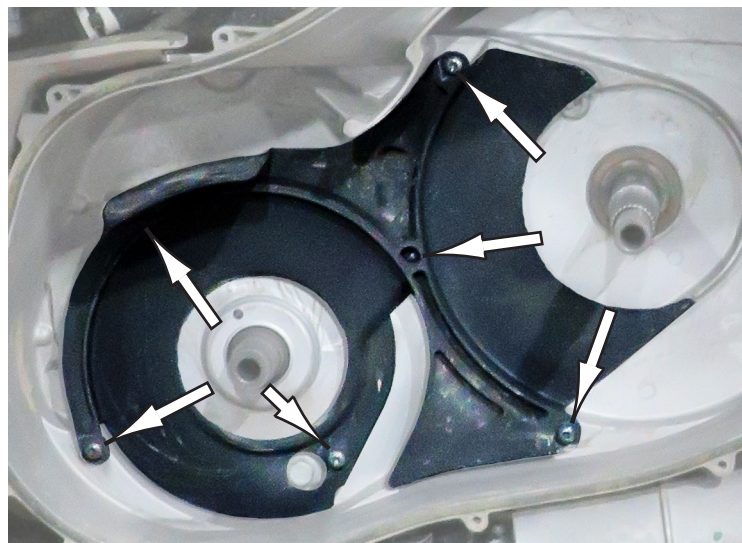

Fig.19b

20. Now place the Drive Clutch onto the Compression Tool and make two marks inline with the two clutch parts so you can reassemble them in the same alignment as they are now, before you take them apart. See **Fig.20**.

21. Next, tighten down the tool holding the clutch cover in place. Now remove the **(6) 10mm Hex Bolts** from the lid as shown in **Fig.21**, and slowly back off the Compression Tool relieving the spring pressure.

22. After cover has been removed, now is a good time to scuff up the sheaves with a Scotch-Brite Pad and clean them from all debris before reinstalling back onto your machine.



Fig.20

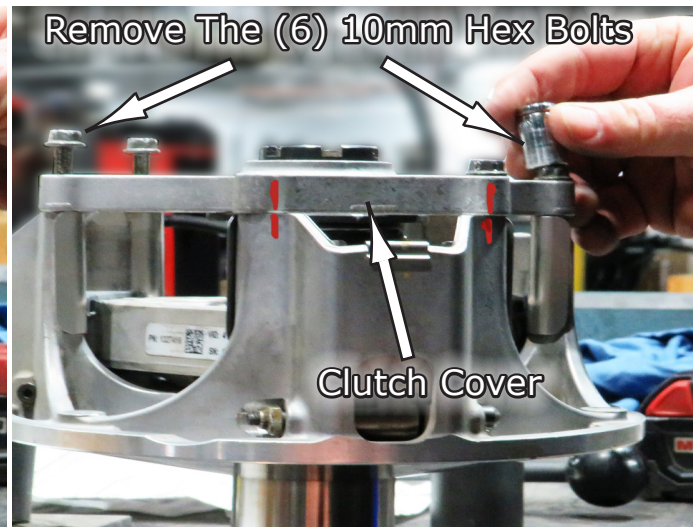

Fig.21

23. Now remove the tool and Spider from the clutch accessing the Weights that you will be changing out with your new ones. See **Fig.22**.

24. With the Spider removed, now remove the three Factory Flyweights. You will remove a Nut and Allen Bolt from each one, and remove the Factory Weight. See **Fig.23**.

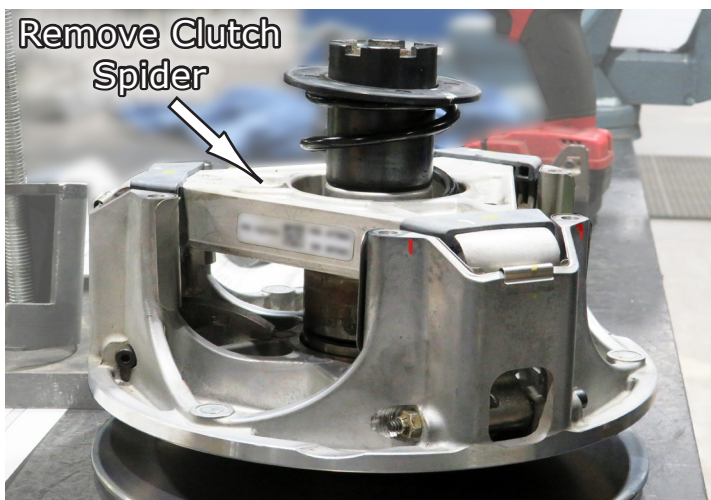

Fig.22

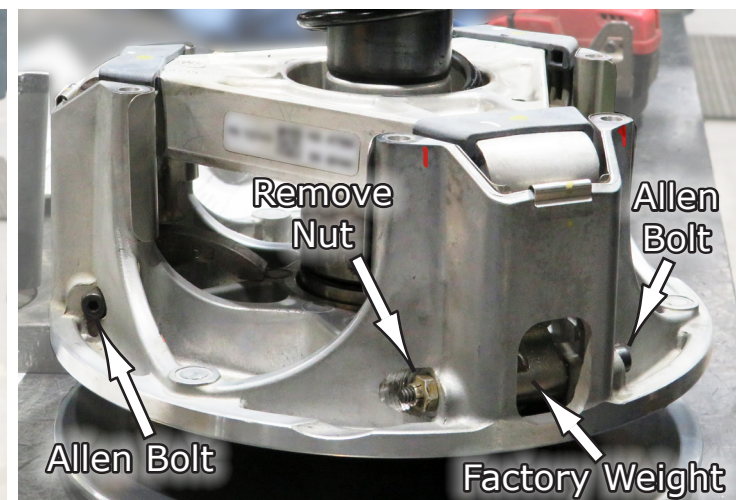
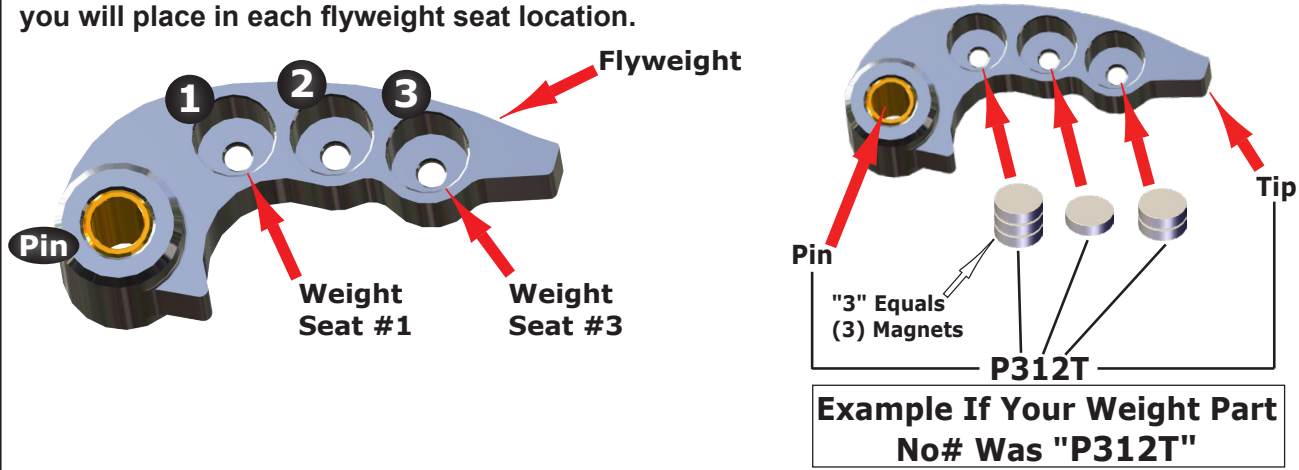

Fig.23

NOTE: After all Flyweights have been removed, you will need to load them with the correct count of magnets in each seat location determined by the number associated with the model number of your kit, or per the options you chose. This number is the one you would have written down in the previous steps. This "P" number tells you how many magnet weights to insert in each seat location. The illustration below gives you an example of this "P" number and how it indicates how many magnets you will place in each flyweight seat location.



MAGNET WEIGHT SAFETY

CAUTION

These magnets have a very strong magnetic force and special care should be taken handling them during adjusting, adding or storing them. Allowing them to rapidly slam together may cause them to shatter sending metal fragments towards you causing possible bodily injury. Always wear proper eye protection when handling them just in case. See below.

- * **Storage:** Keep magnets in plastic bag, if possible, to prevent attraction of magnetic debris.
- * **Work Area:** Make sure work area is clean and free of metal debris.
- * **Handling:** When adding or removing magnets from the weight seats, use an Allen wrench to push magnets out of the seat, from the bottom, by inserting the Allen wrench thru the hole in the bottom of the seats. See above illustration. Also use an Allen wrench to Install magnets by letting them down slowly into the Weight Seat as to keep them from slamming together.

MAGNETIC ADJUSTABLE WEIGHT BASICS

These weights may or may not come pre-loaded in your kit. However, if changes are made to the machine such as tire size or elevation cargo etc., this kit will allow you to make adjustments without replacing the weights in most situations. Here are some suggestions:

- The hole **Closest to the Pin** will have a greater affect with **Low RPM** belt squeeze and RPM.
- The **Center Hole** will have the greatest affect on **Midrange RPM** and belt squeeze.
- The hole **Farthest from the Pin** will have the most affect on **Top RPM** and belt squeeze.
- **ALL WEIGHTS MUST BE LOADED IDENTICALLY TO ENSURE PROPER CLUTCH BALANCE!**

If adjustment to the RPM is needed, generally we adjust by adding or subtracting from the Middle Weight Seat as the Seat closest to the Pin is usually close to full. The Middle Seat will be a smaller adjustment to the Top RPM whereas the Seat closest to the Tip will have a larger adjustment. So, more RPM is needed if using larger tires or higher elevation, whereas lower RPM is needed if using smaller tires and or lower elevation.

25. So at this point, load all (3) Flyweights with the correct count of magnets determined by your "P" number, and then install all three of your New REV-1 weights back into the clutch using your existing Factory Hardware. **Torque Nuts to 18in.lbs.** See **Fig.24.**



26. After all weights have been installed, replace the Spider and insert the ORANGE Spring from your New Kit in place of the Factory Spring as shown in **Fig.25.**

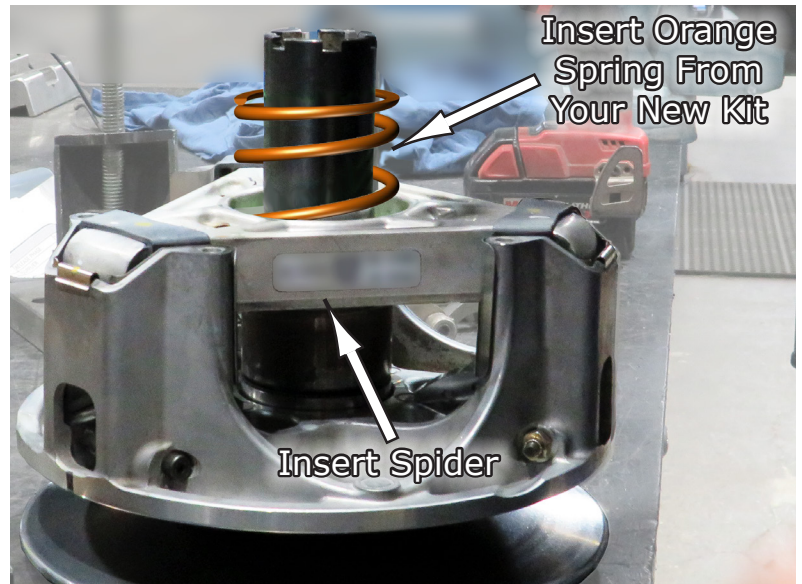

27. Now replace the Spring Retainer with the lip facing down into the spring to hold it in place. See **Fig.26.**

Fig.25

28. Then install the Clutch Cover on top of the Spring and compress down using your Compression Tool, ready to install the bolts. See **Fig.27a.** While still compressed using the tool, install the (6) factory bolts you previously removed, and torque to **9ft.lbs.** **Fig.27b** shows the bolts installed and torqued.

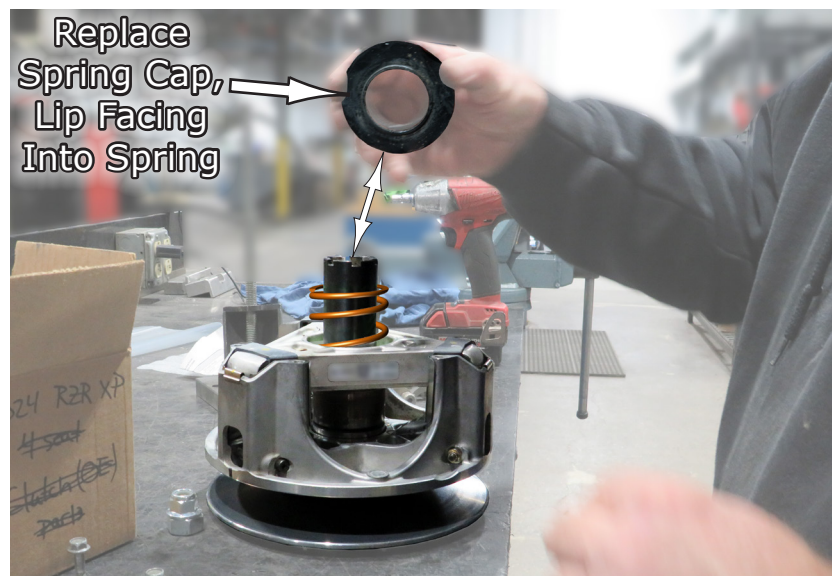

Fig.26

NOTE: Apply a small amount of Blue Loctite to all 6 bolts.



Fig.27a

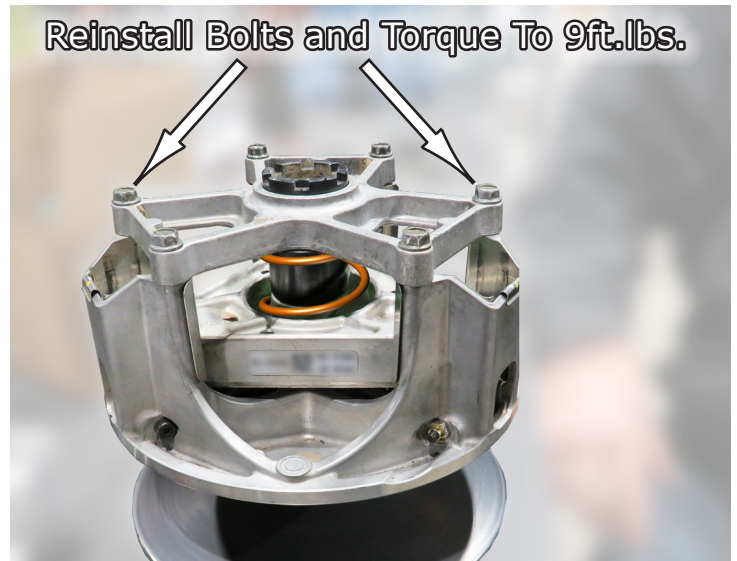

Fig.27b

29. Now replace Driven Clutch back onto the shaft and replace the Center Retainer Bolt and Washers, and Torque to **55ft.lbs.** See **Fig.28.**

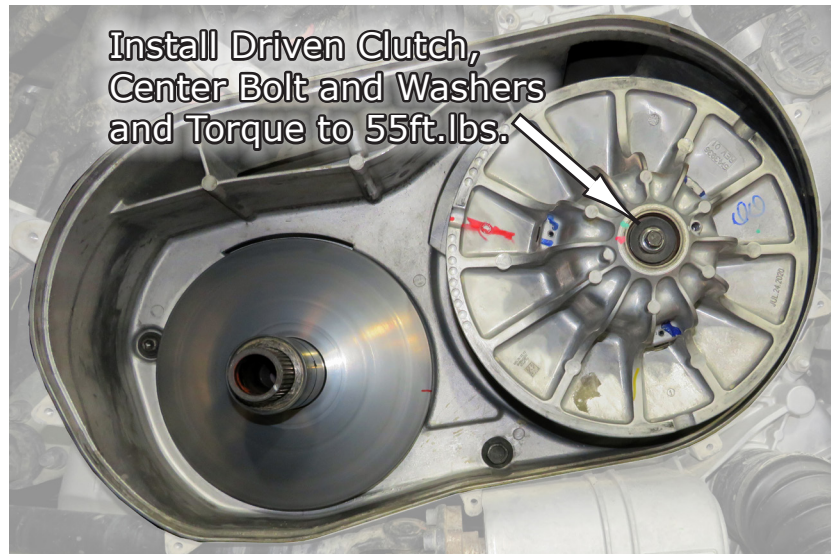

Fig.28

30. Next, replace the Drive Clutch onto the spindle and install the Center Retaining Bolt, and Torque to **140ft.lbs**, back off bolt 2 turns and then Re-torque to **118 ft.lbs.** See **Fig.29.**



Fig.29

31. Now install your belt back onto the machine. Be sure that the writing and numbers on the outside of the belt are oriented, or facing in the direction so that you can read them as you are facing the machine, or in the same direction it was in before you took it off. This will ensure proper function and wear.

Use Clutch Tool to spread sheaves apart while installing the belt. Then back out the set screw all the way or remove the clutch tool (if your tool has a threaded end) to relieve the clutch. Rotate the clutch 5-7 times to seat the belt into the clutch sheaves. The belt will adjust to the correct depth into the sheaves. No other adjustment needed. See **Fig.30**.



Fig.30

▪ After verifying that all items have been properly installed & torqued, start engine. Engagement should be between **1700-2200rpm** after initial engagement.

CAUTION: When clutches are fully shifted through the shift cycle, RPM can go up to **8500rpm** at top speed!

POSSIBLE ISSUE! Checking Transmission Alignment: Start unit without cover on. Shift between gears. If it is hard to shift, proceed to **FIX2** install instructions. **FIX2** kit (included in your kit) will only adjust alignment if the drive belt is touching the outer drive clutch sheave. If there are no hard-shifting issues, then it is OK to install clutch cover.

32. Once all the above checks out, now replace cover and the exit air breather hose, shock and shock guard etc.

NOTE: Re-torque drive clutch/driven clutch bolts to proper Polaris specs after 100 miles of operation. Failure to do so could cause future damage to clutches or injury to operator.

TECH TIPS:

1. Drain water out of clutch cover after washing unit or driving thru deep water before operating as this could cause a flat spot/damage belt and wear the drive clutch causing a clutch face groove/damage.
2. Clean clutches at least once a season for normal maintenance.
3. Under Severe conditions such as MUD BOG riding/racing, clean clutches daily.
4. Do not install partial kit as kit was designed to work correctly using all enclosed items.
5. Do not mix other company's parts with kit as this could cause damage/improper operation.

Torque Specs: Companies change specs, so verify any & all bolt tightening specs by checking with your Polaris Dealer, Service Manual, Owners Manual or Polaris Industries.

Liability Statement

SuperATV's® products are designed to best fit user's ATV/UTV under stock conditions. Adding, modifying, or fabricating any factory or aftermarket parts will void any warranty provided by SuperATV® and is not recommended. SuperATV's® products could interfere with other aftermarket accessories. If user has aftermarket products on machine, contact SuperATV® to verify that they will work together.

Although SuperATV® has thousands of satisfied customers, user should be aware that installing lift kits, long travel, or suspension kits, tires, etc. will change the ride of machine and may increase maintenance and part wear. Operating any off-road machine while, or after, consuming alcohol and/or drugs increases risk of bodily harm or death. No warranty or representation is made as to this product's ability to protect user from severe injury or death. SuperATV® urges operators and occupants to wear a helmet and appropriate riding gear at all times.

By purchasing and installing SuperATV® products, user agrees that should damages occur, SuperATV® will not be held responsible for loss of time, use, labor fees, replacement parts, or freight charges. SuperATV®, nor any 3rd party, will not be held responsible for any direct, indirect, incidental, special, or consequential damages that result from any product purchased from SuperATV®. The total liability of seller to user for all damages, losses, and causes of action, if any, shall not exceed the total purchase price paid for the product that gave rise to the claim.

SuperATV® will warranty only parts provided by SuperATV®. Any damage or problems with OEM housings, bearings, seals, or other manufacturers' products will not be covered by SuperATV®. SuperATV® parts and products are not warranted if item was not installed properly, misused, or modified.

Installing, adding, modifying, or fabricating any factory or aftermarket product to your ATV/UTV may violate certain local, state, and federal laws. Be advised that laws vary depending on town, city, county, state, etc. Use of certain products on public streets, roads, or highways may be in violation law. The Buyer is solely and exclusively legally and personally responsible for any violation of the law by the installation or use of the product. You must abide by all local, state, and federal laws, including but not limited to vehicle safety, traffic laws, and ordinances. It is your responsibility to know the laws and how they apply to you.

The Buyer is responsible to fully understand the capability and limitations of his/her vehicle according to manufacturer specifications, warnings and instructions and agrees to hold SuperATV® harmless from any damage resulting from failure to adhere to such specifications, warnings and/ or instructions. The Buyer is also responsible to obey all applicable federal, state, and local laws and ordinances when operating his/her vehicle while using this product, and the Buyer agrees to hold SuperATV® harmless from any violation thereof.

If you have any problems or questions on this kit, contact us by email at [Superatv.com](mailto:Sales@superatv.com).

Need help with your installation?



sales@superatv.com



www.superatv.com



1-855-743-3427



8:00am - 9:00pm EST M-Th
8:00am - 7:00pm EST Friday
9:00am - 2:00pm EST Saturday



Like SuperATV on Facebook to keep up to date on new products!