

INSTALLATION INSTRUCTIONS
Snorkel Kit: for Polaris RZR XP[®] 1000

- Do not discard packaging until product has been successfully installed.
- Secure Tubing away from hot and/or rotating components.

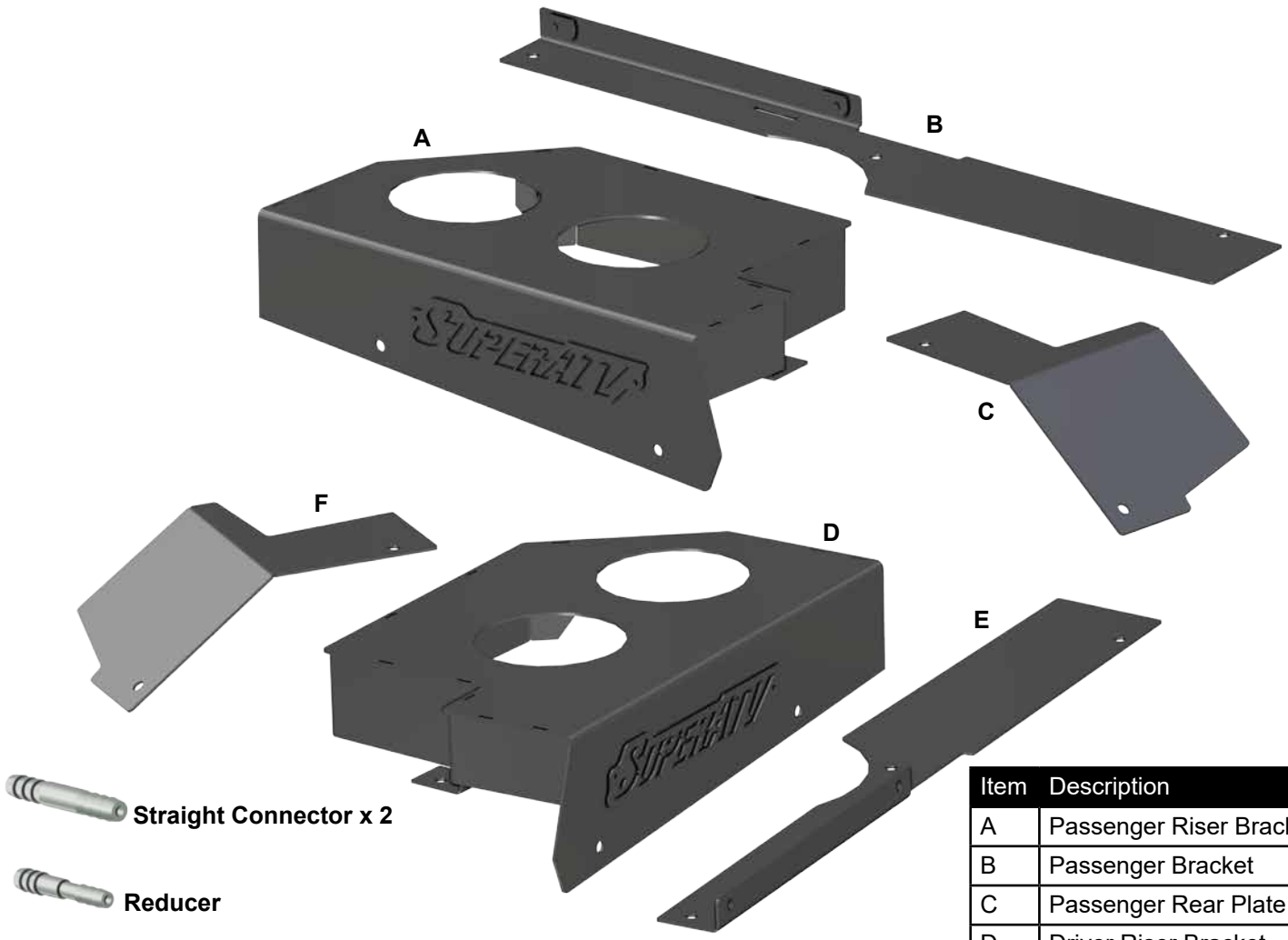

 Straight Connector x 2

 Reducer

 Air Intake Plug

 Small Wire Tie x 10

 Large Wire Tie x 5

Item	Description
A	Passenger Riser Bracket
B	Passenger Bracket
C	Passenger Rear Plate
D	Driver Riser Bracket
E	Driver Bracket
F	Driver Rear Plate



Clamp x 3

- Clutch Puller, not included, will be needed.
- SuperATV recommends removing Bellows before extended amounts of high speed riding.

(disregard remaining)
 (Kit Contents continue on following page)

Need help with your installation?

 sales@superatv.com
  www.superatv.com

 1-855-743-3427
  8:00am - 8:00pm EST M-Th
 8:00am - 7:00pm EST Friday
 9:00am - 2:00pm EST Saturday

Read instructions and view illustrations before beginning.

Thank You
 For Choosing
SUPERATV.COM[®]

(Kit Contents continued)

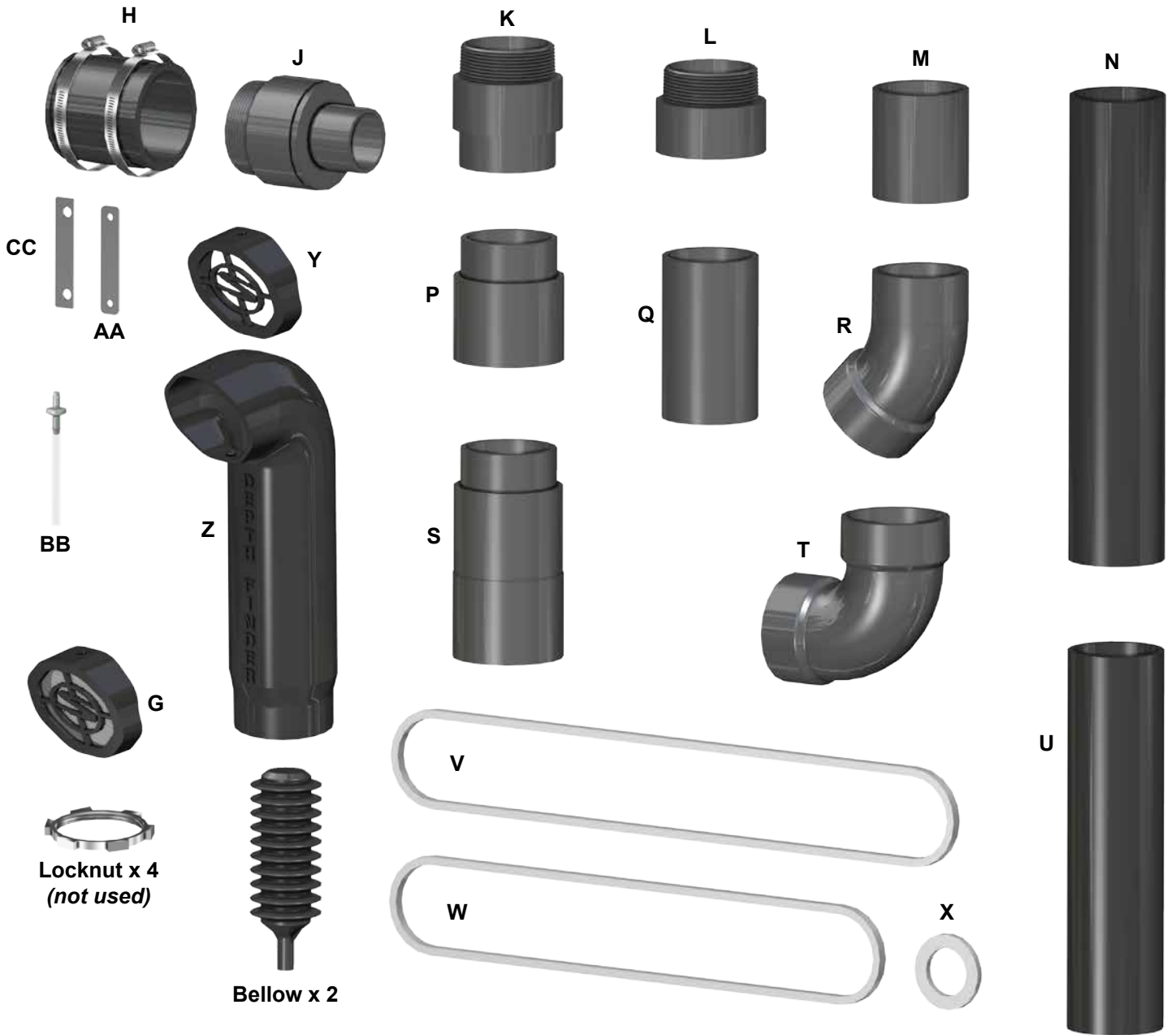

(disregard any remaining hardware)

Item	Description	Item	Description
G	Faceplate x 3	T	90° Elbow x 2
H	Rubber Connector x 3	U	13-3/4" Pipe
J	Riser Pipe Assembly 1	V	Clutch Housing Gasket
K	Riser Pipe Assembly 2 x 2	W	Air Box Gasket
L	Threaded Connector	X	Clutch Backing Plate Gasket
M	3" Pipe x 2	Y	Faceplate (no mesh)
N	17" Pipe	Z	Snorkle Riser x 4
P	Snorkle Riser Pipe Assembly x 2	AA	Solenoid Bracket
Q	6" Pipe	BB	Fuel Vent Hose x 2
R	45° Elbow x 3	CC	Support Plate x 2
S	Riser Pipe Assembly 3 x 2		

(Kit Contents continued)



T-Fitting



Elbow Reducer

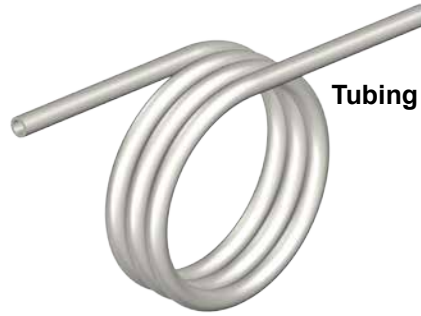

Tubing

Liability Statement

SuperATV's® products are designed to best fit user's ATV/UTV under stock conditions. Adding, modifying, or fabricating any factory or aftermarket parts will void any warranty provided by SuperATV® and is not recommended. SuperATV's® products could interfere with other aftermarket accessories. If user has aftermarket products on machine, contact SuperATV® to verify that they will work together.

Although SuperATV® has thousands of satisfied customers, user should be aware that installing lift kits, long travel, or suspension kits, tires, etc. will change the ride of machine and may increase maintenance and part wear. Operating any off-road machine while, or after, consuming alcohol and/or drugs increases risk of bodily harm or death. No warranty or representation is made as to this product's ability to protect user from severe injury or death. SuperATV® urges operators and occupants to wear a helmet and appropriate riding gear at all times.

By purchasing and installing SuperATV® products, user agrees that should damages occur, SuperATV® will not be held responsible for loss of time, use, labor fees, replacement parts, or freight charges. SuperATV®, nor any 3rd party, will not be held responsible for any direct, indirect, incidental, special, or consequential damages that result from any product purchased from SuperATV®. The total liability of seller to user for all damages, losses, and causes of action, if any, shall not exceed the total purchase price paid for the product that gave rise to the claim.

SuperATV® will warranty only parts provided by SuperATV®. Any damage or problems with OEM housings, bearings, seals, or other manufacturers' products will not be covered by SuperATV®. SuperATV® parts and products are not warranted if item was not installed properly, misused, or modified.

Installing, adding, modifying, or fabricating any factory or aftermarket product to your ATV/UTV may violate certain local, state, and federal laws. Be advised that laws vary depending on town, city, county, state, etc. Use of certain products on public streets, roads, or highways may be in violation law. The Buyer is solely and exclusively legally and personally responsible for any violation of the law by the installation or use of the product. You must abide by all local, state, and federal laws, including but not limited to vehicle safety, traffic laws, and ordinances. It is your responsibility to know the laws and how they apply to you.

The Buyer is responsible to fully understand the capability and limitations of his/her vehicle according to manufacturer specifications, warnings and instructions and agrees to hold SuperATV® harmless from any damage resulting from failure to adhere to such specifications, warnings and/ or instructions. The Buyer is also responsible to obey all applicable federal, state, and local laws and ordinances when operating his/her vehicle while using this product, and the Buyer agrees to hold SuperATV® harmless from any violation thereof.

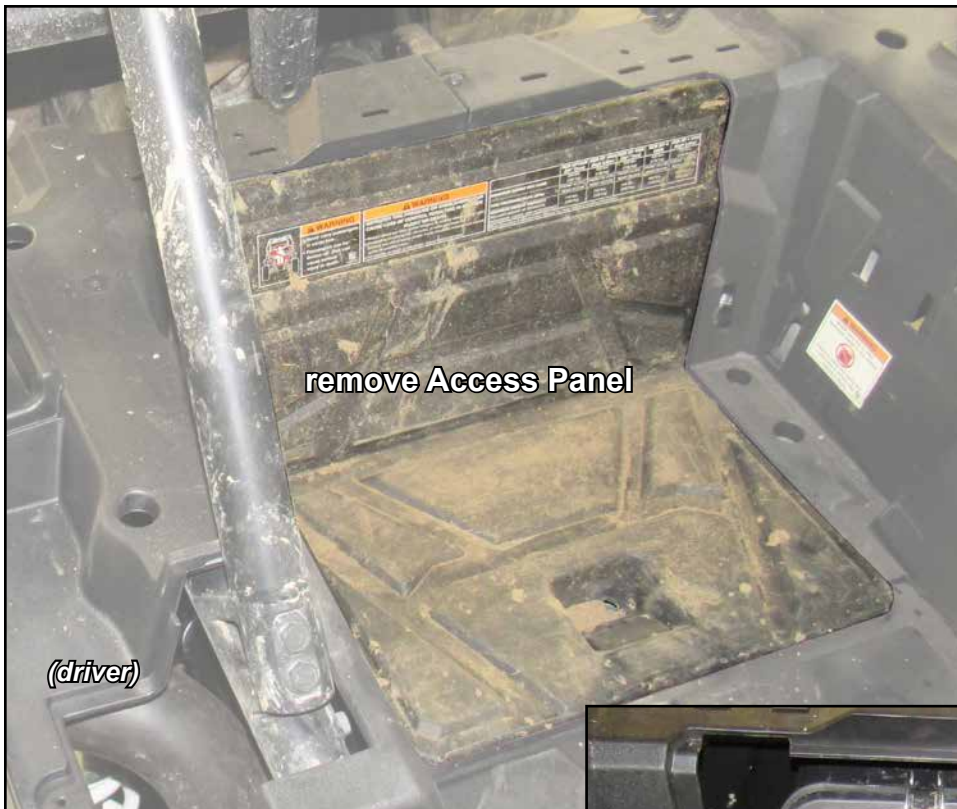

remove Access Panel

(driver)



remove Airbox Cover
and Filter



replace stock Gasket with provided Airbox Gasket

- Drill a Ø3/8" hole into Airbox Cover and install Elbow Reducer.

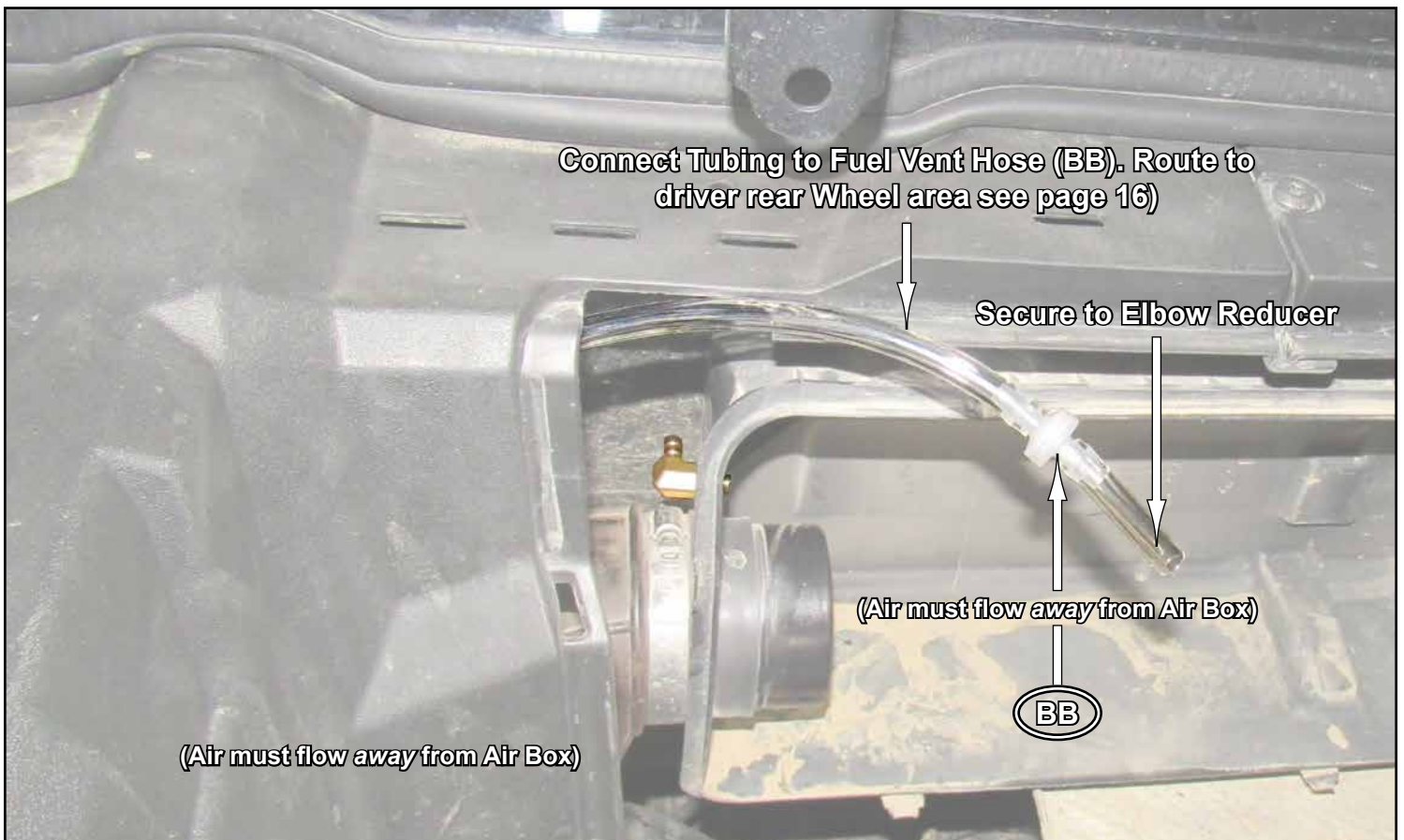

- Blow through Valve; air should be coming out opposite end.
- Remove from mouth and insert end (from mouth) onto Tube.



- Install Clip Nut to Solenoid Bracket (AA).



- Install Clip Nut to Solenoid Bracket (AA).



- Install Solenoid to Solenoid Bracket (AA). Secure Bracket with hardware shown.



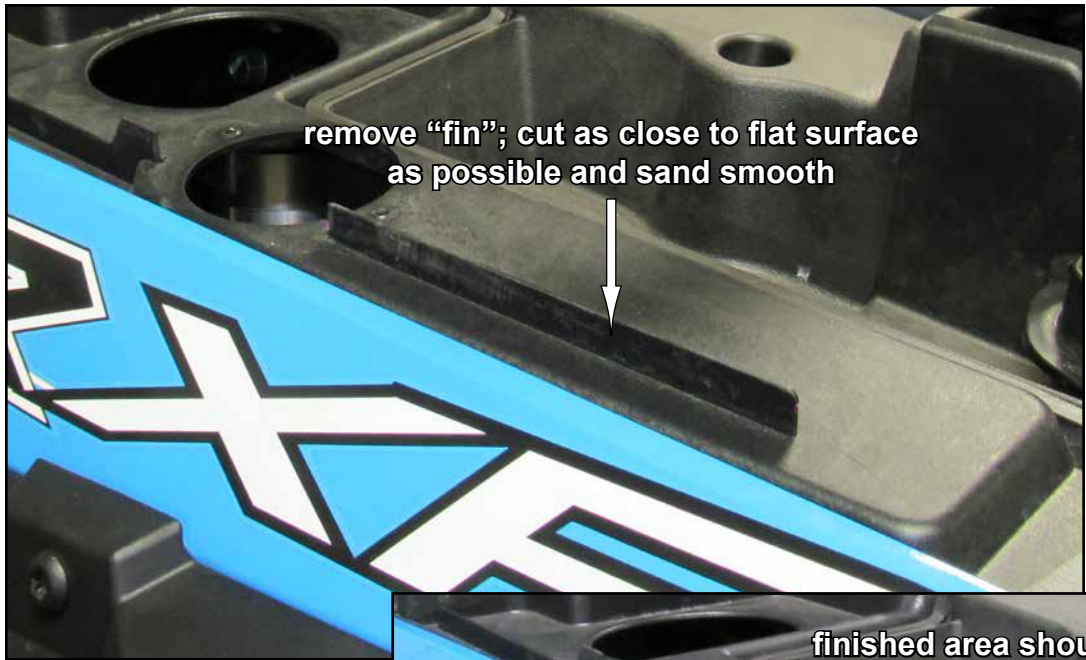

- Install Driver Bracket (E) with hardware shown.

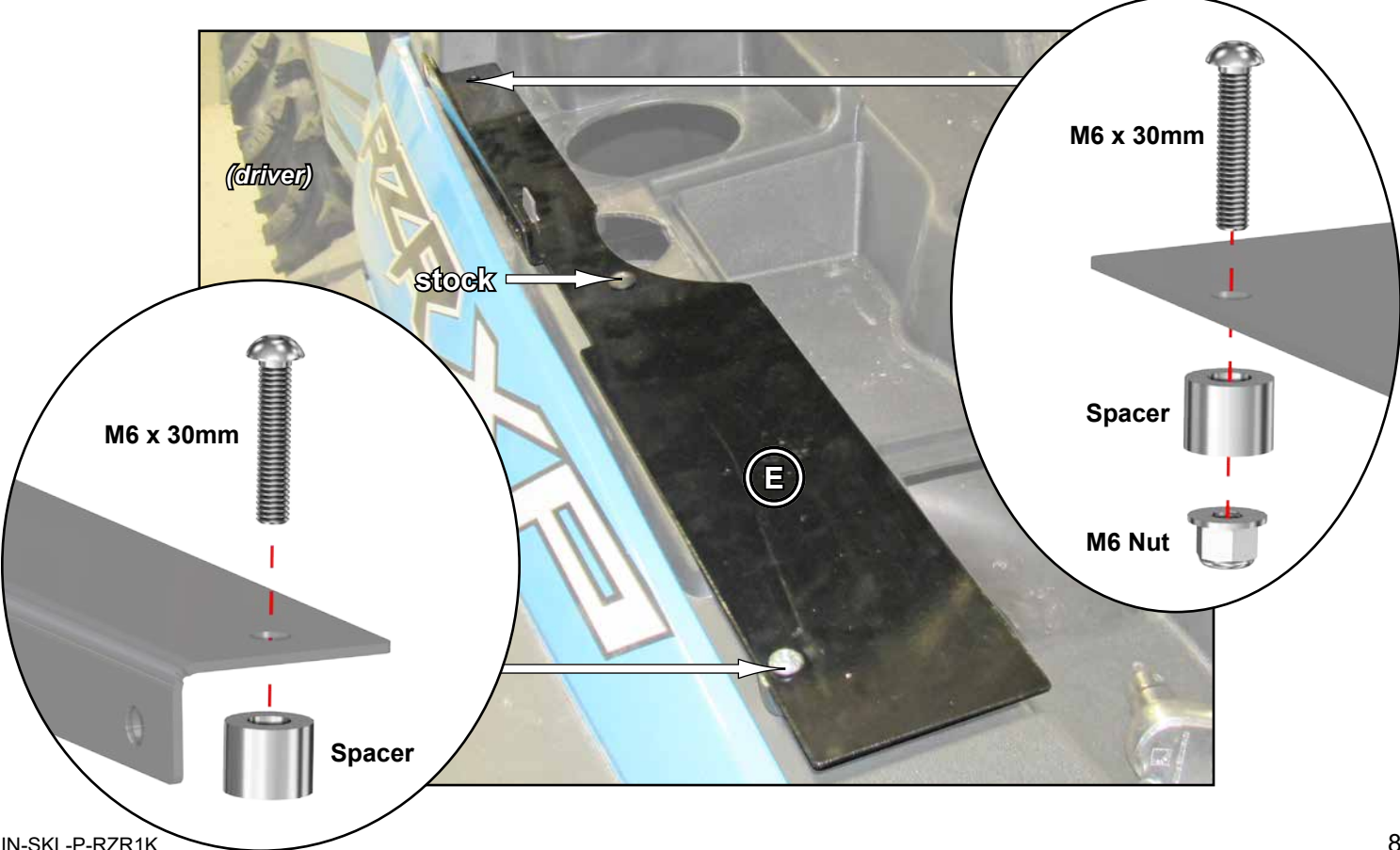

- Install Passenger Bracket (B) with hardware shown.

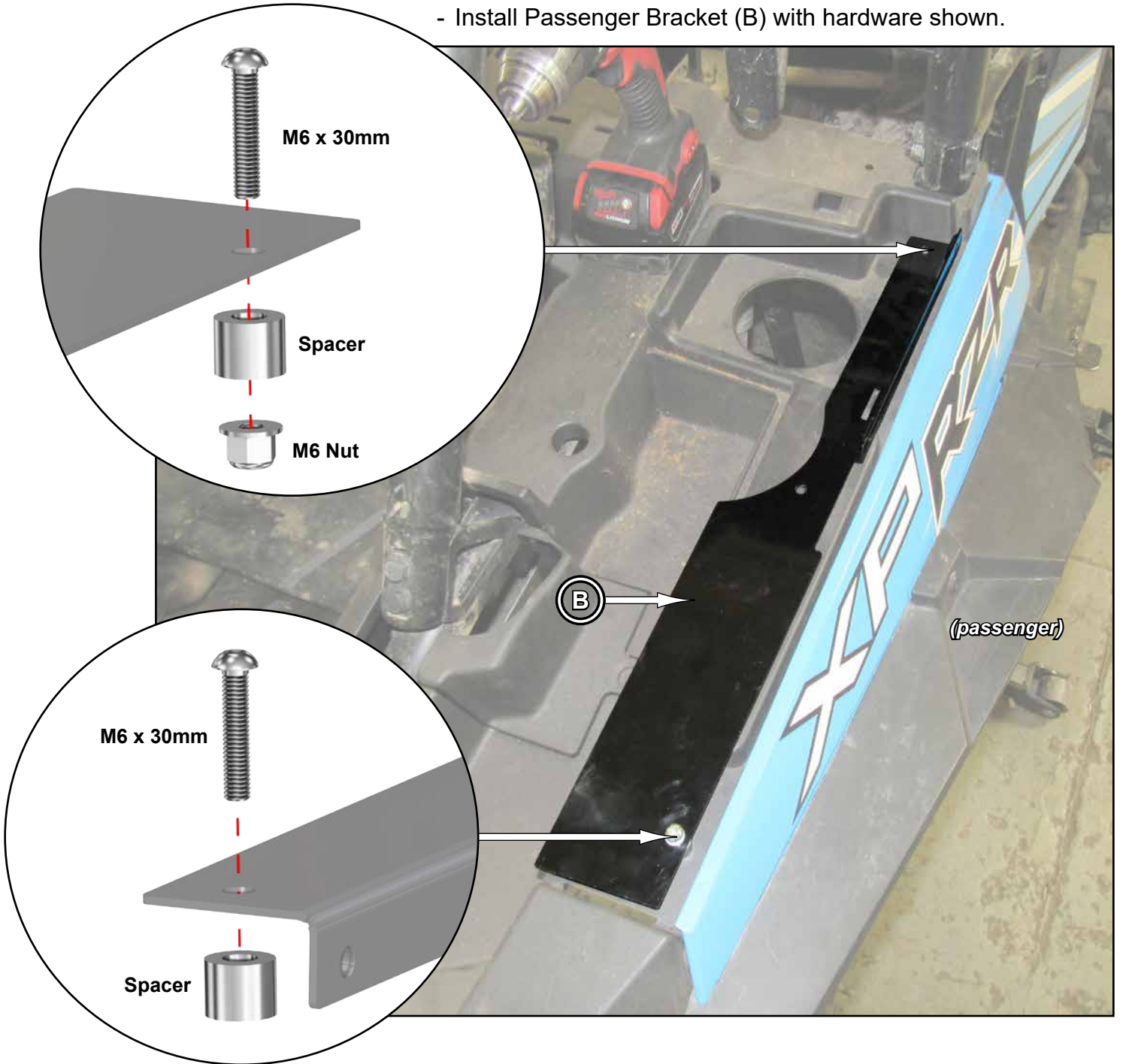

- Temporarily install Passenger Riser Bracket (A).
- Insert 6" Pipe (Q) through Passenger Riser Bracket (A).

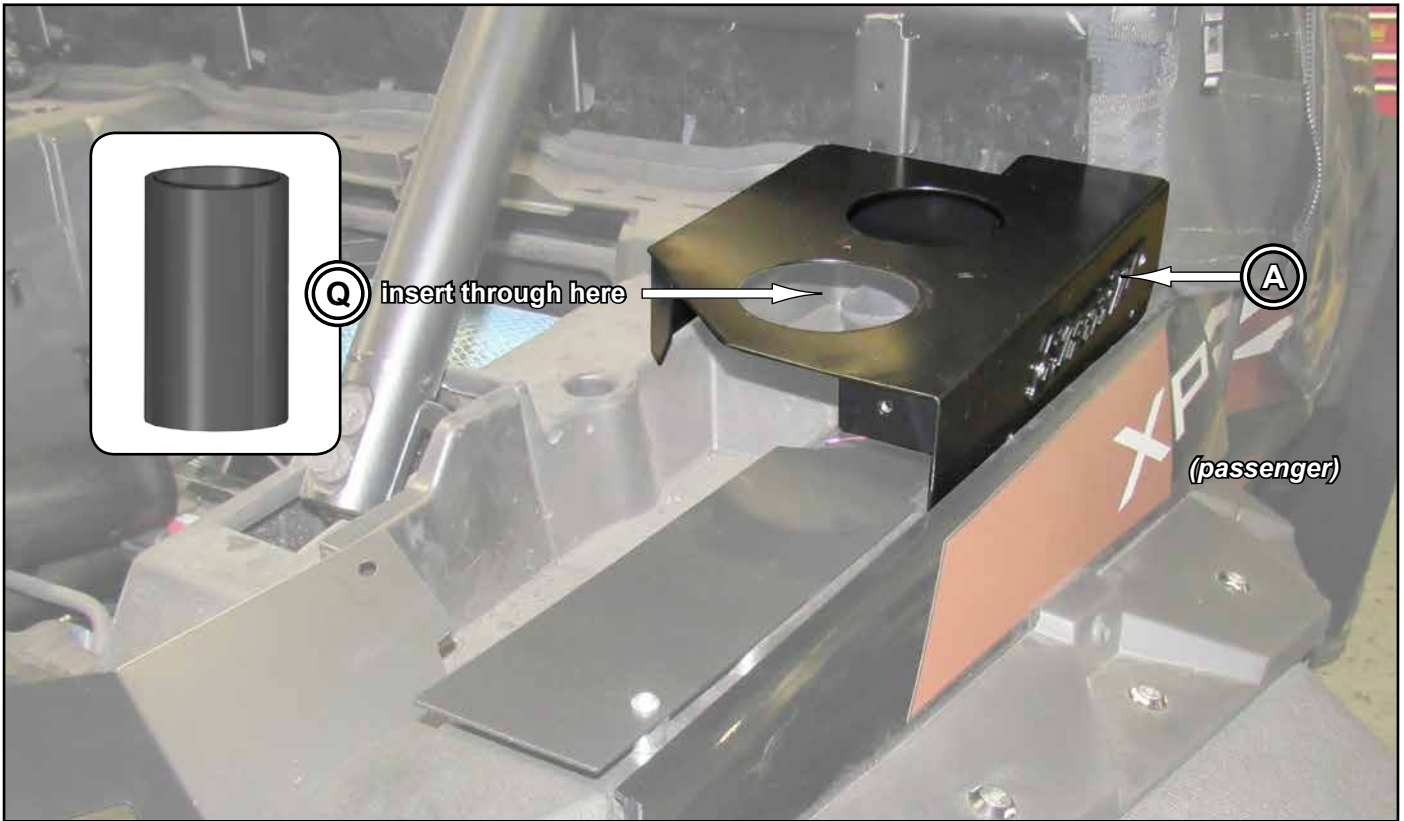

- Mark 6" Pipe (Q) outline onto plastic.
- Remove Pipe and Passenger Riser Bracket.

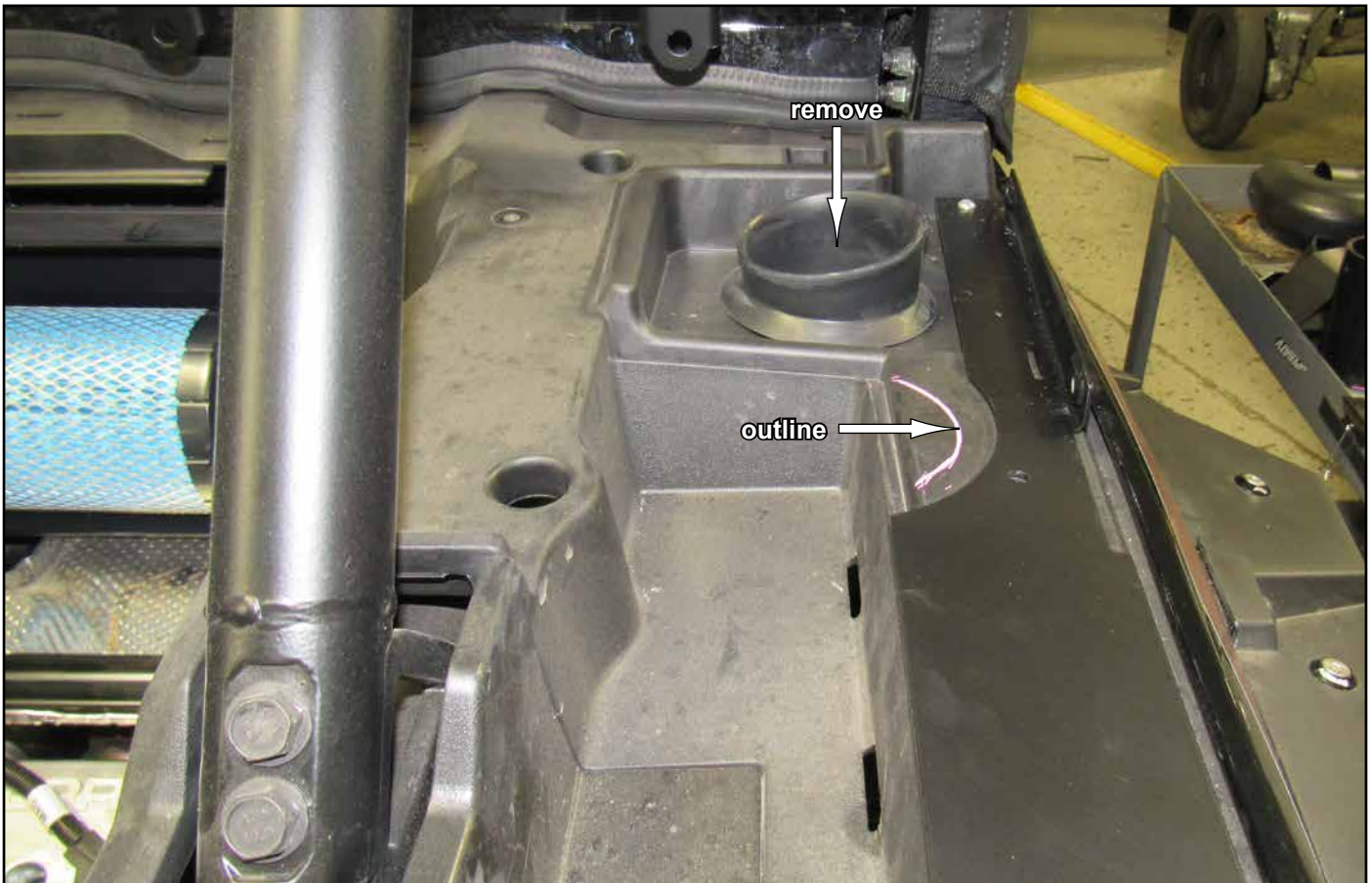

- Use a Ø3" hole saw (not included) and cut through plastic. STOP when saw reaches area shown.



- From inside fenderwell, remove remaining plastic to complete initial cut. SuperATV recommends a jigsaw or similar tool.



- Continue with Ø3" hole saw (not included) and finish cut through plastic.



repeat steps for driver side

Clutch Removal

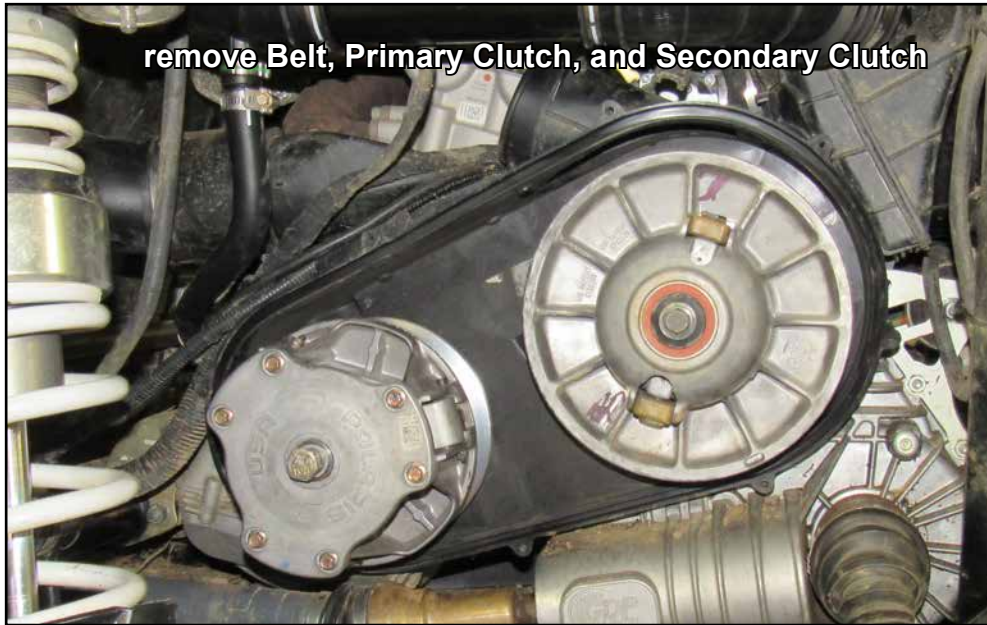
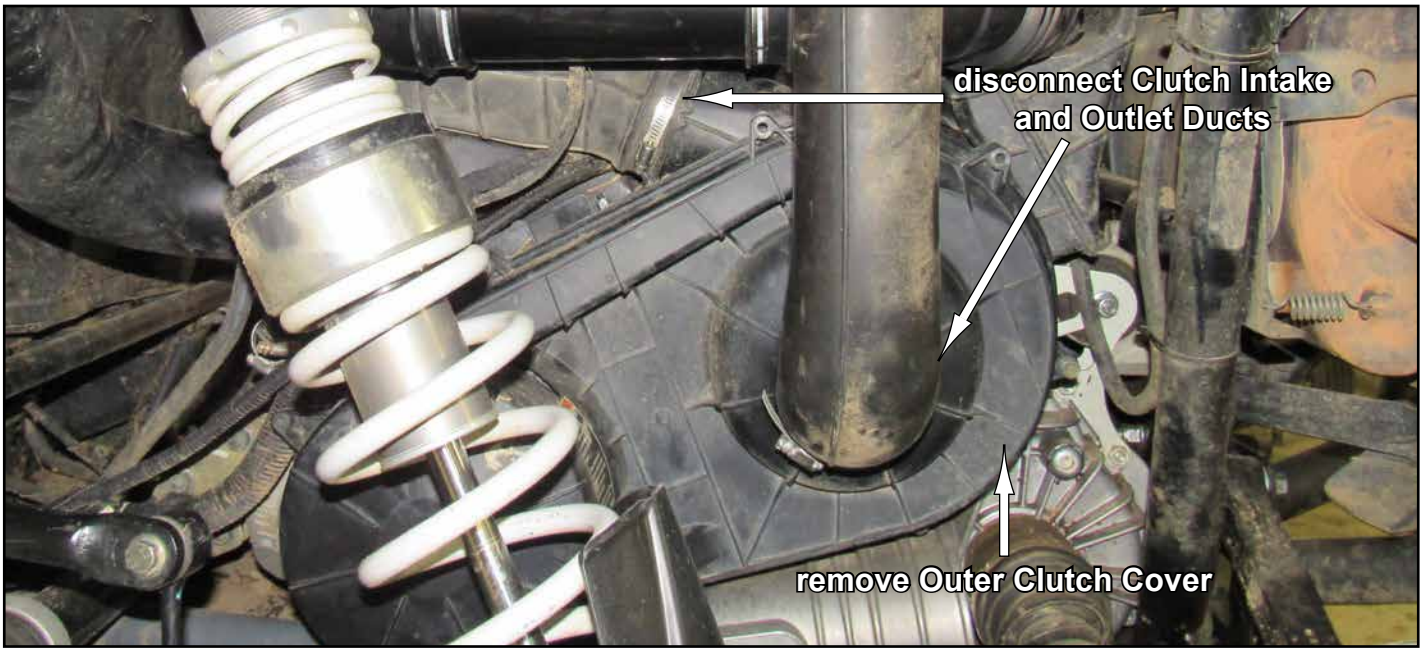

Clutch Housing Modifications



- remove Ducts
- apply RTV 100% Silicone
- reinstall Ducts

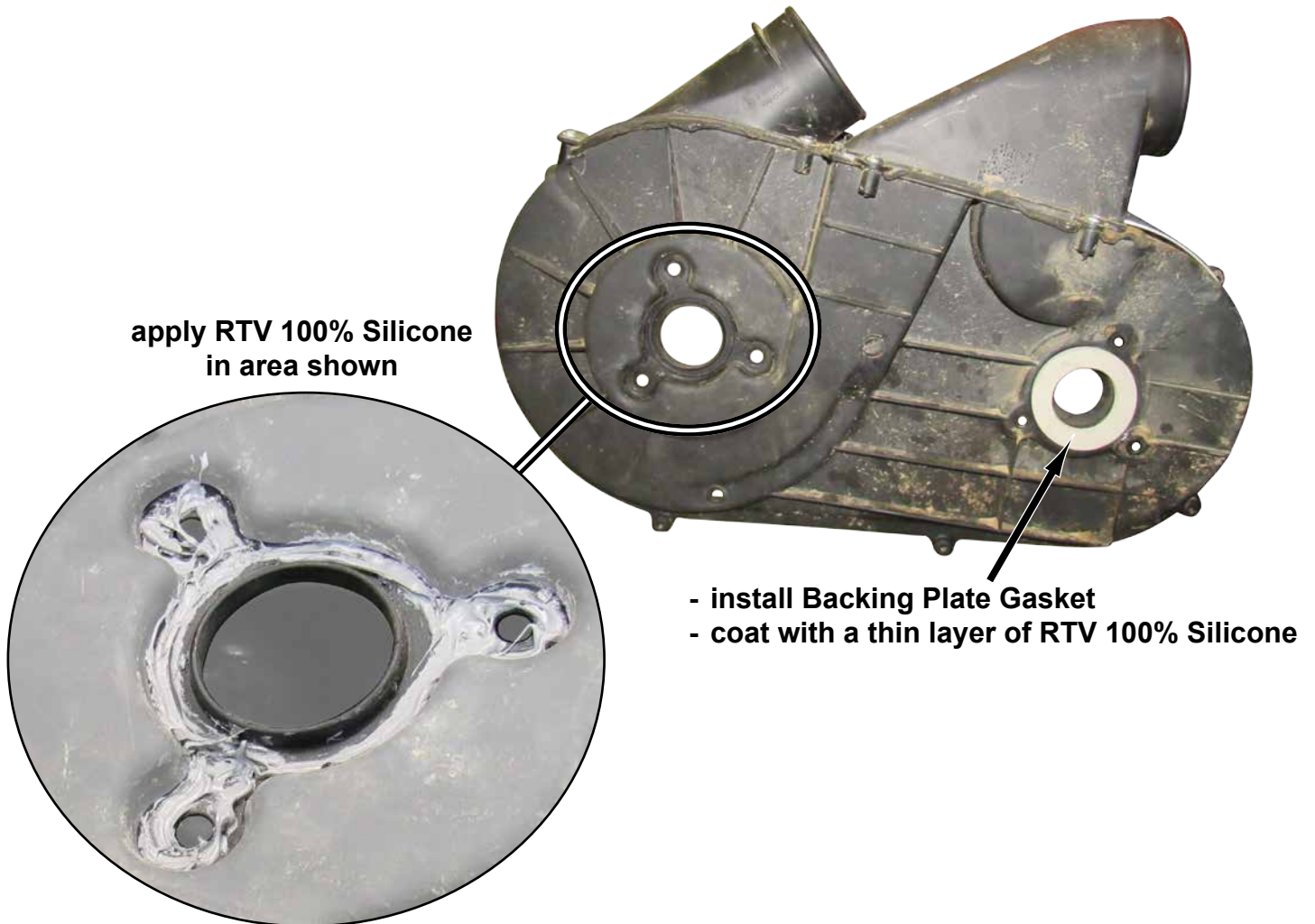

apply RTV 100% Silicone
in area shown

- install Backing Plate Gasket
- coat with a thin layer of RTV 100% Silicone

Front Differential Vent



- Connect Bellow to stock Hose and secure tubing to Frame with Wire Tie.



Fuel Vent



- Blow through Valve; air should be coming out opposite end.
- Remove from mouth and insert end (from mouth) onto Tube.

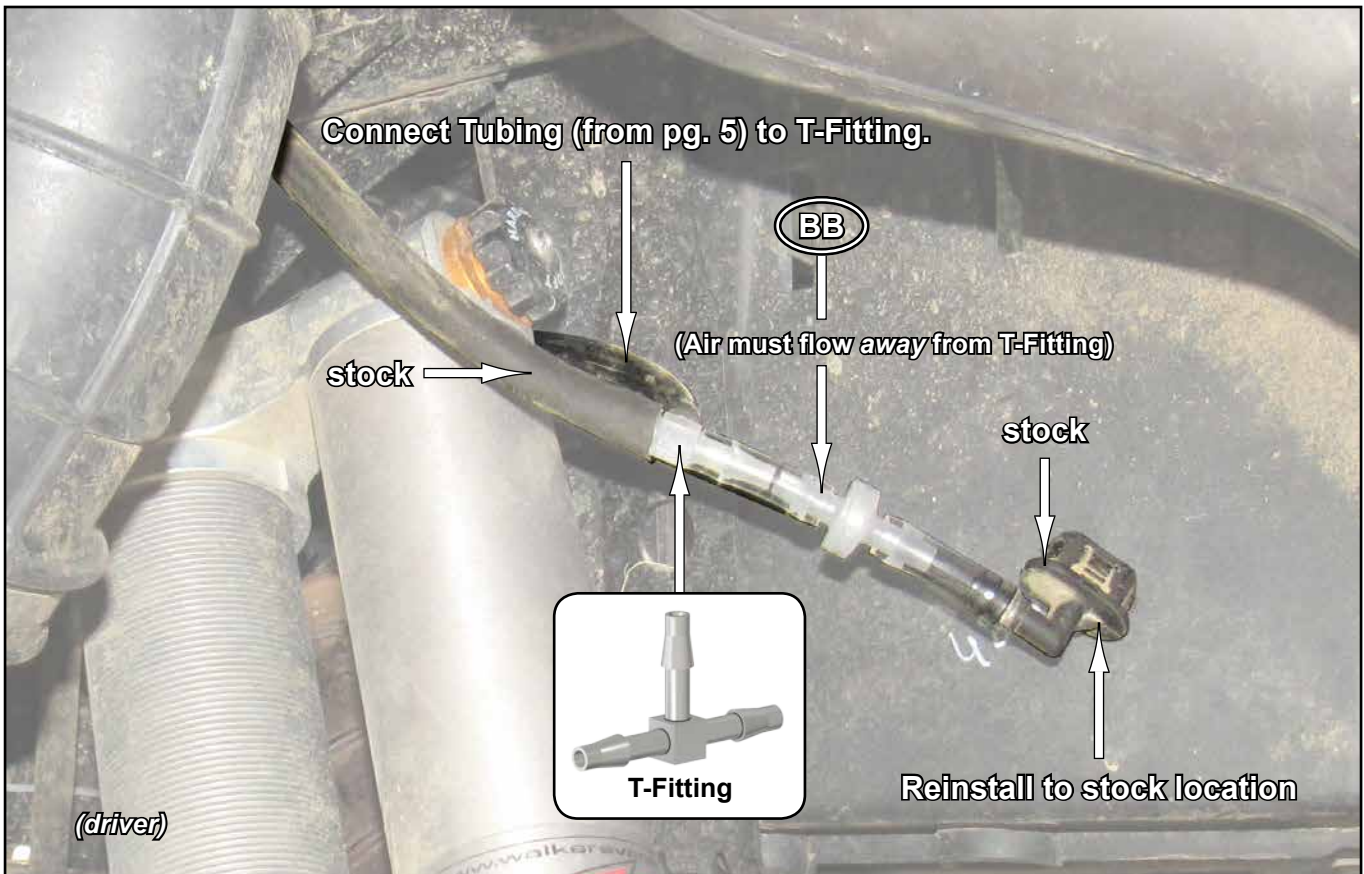

Transmission Vent

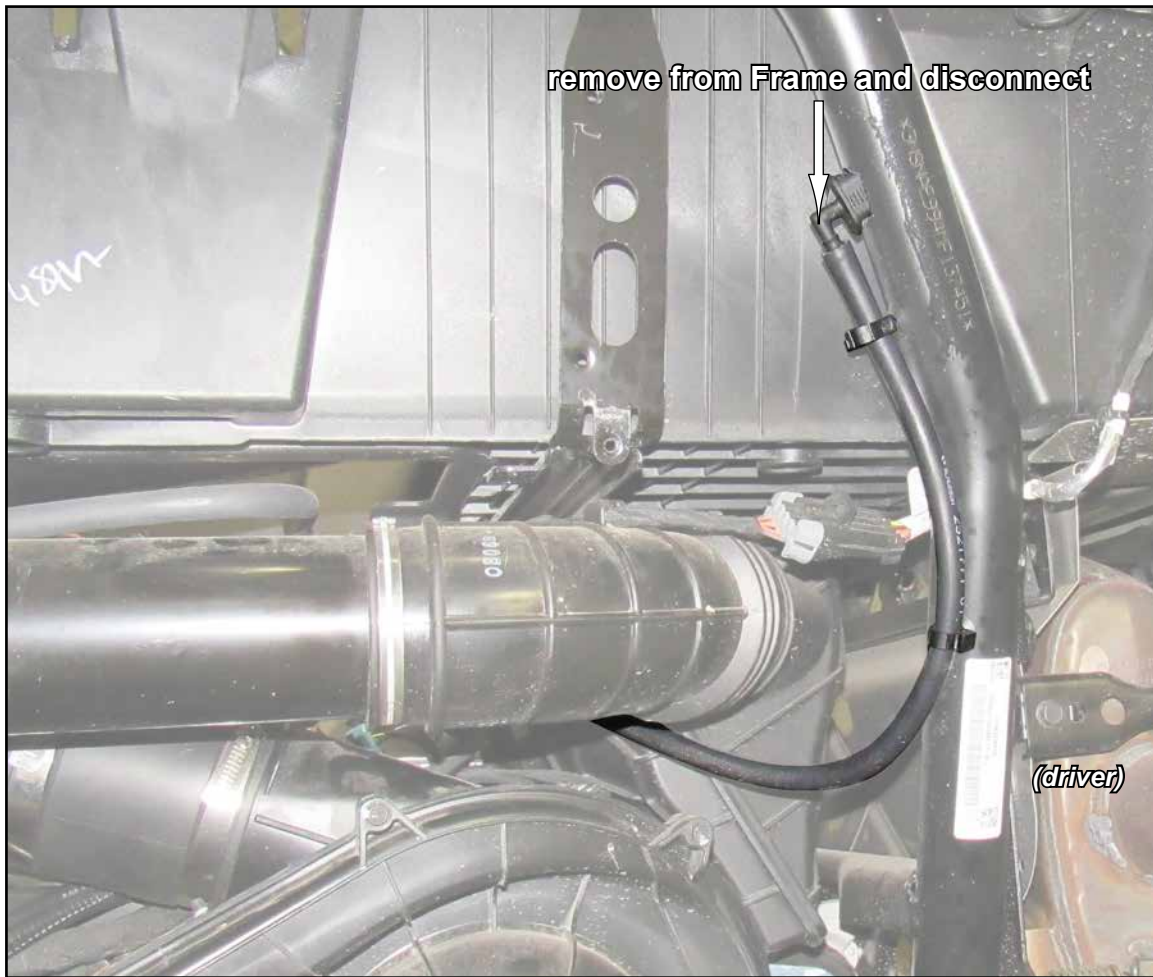

- Connect Bellow to stock Hose and secure to Frame.

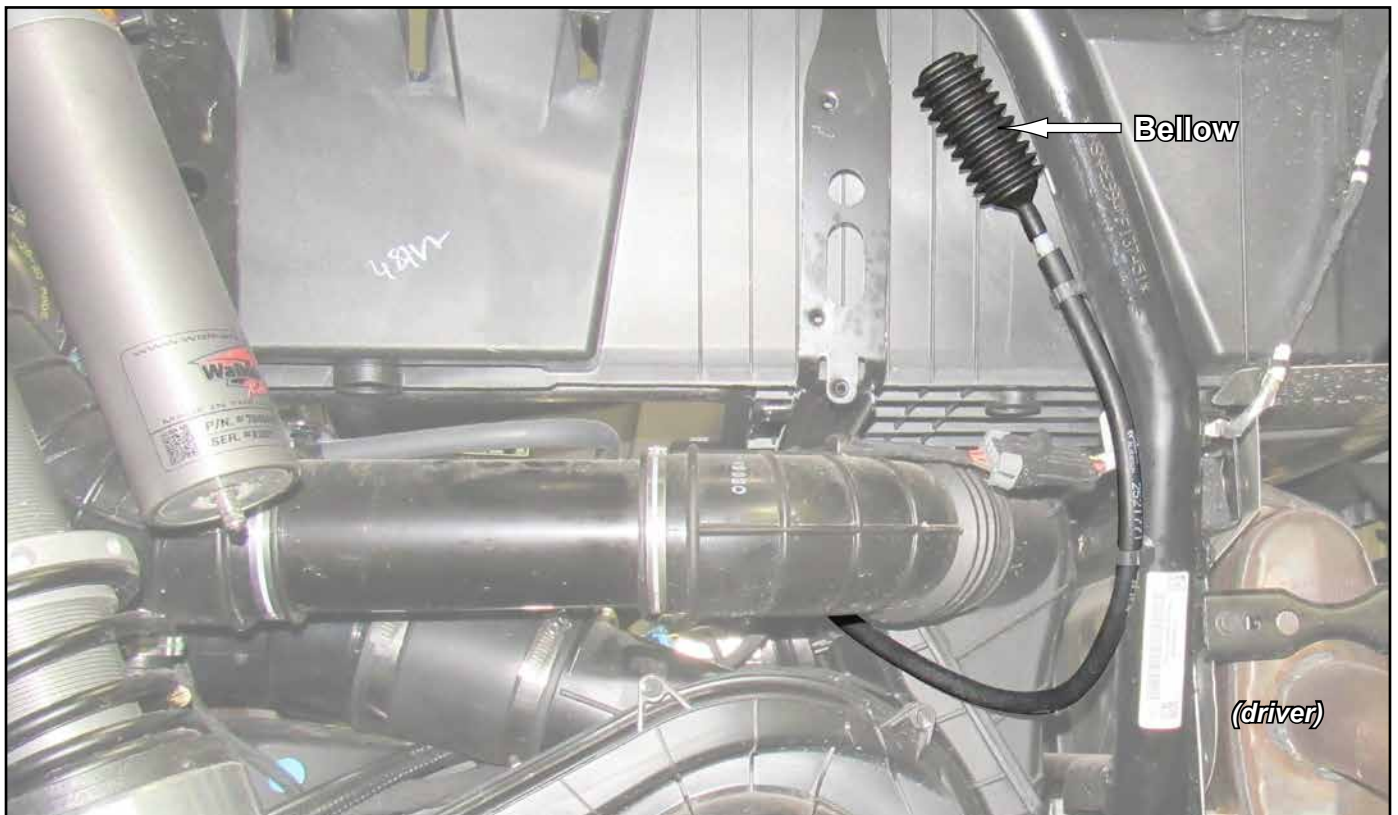

- Reinstall stock Clutch Intake Hose.



- Feed stock Clutch Intake Hose through new hole and secure to Riser Pipe Assembly 1 (J) with stock Clamp.

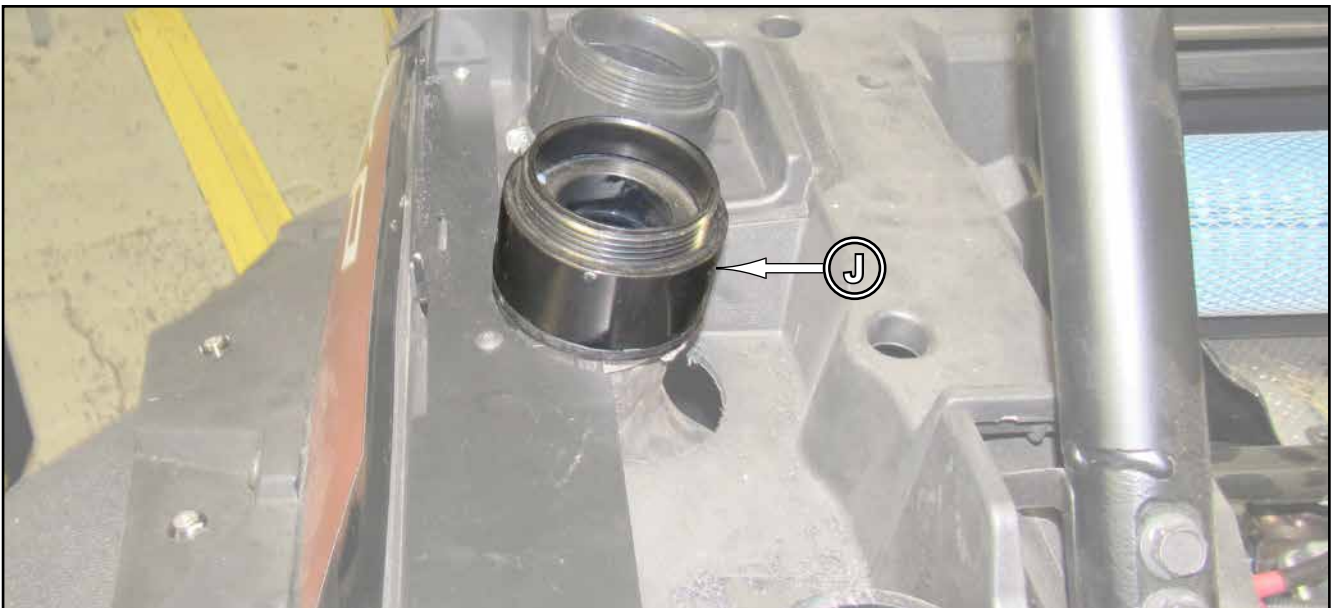

- Secure Belt Intake Hose to Riser Pipe Assembly 2 (K) with Clamp.
- Use a lubricant on Hose to ease installation.





- Install Driver Riser Bracket (D) to Driver Bracket (E) with hardware shown.
- Secure Riser Pipe Assembly 3 (S) and Snorkle Riser Pipe Assembly (P) to previously installed Riser Pipe Assemblies (J)(K).

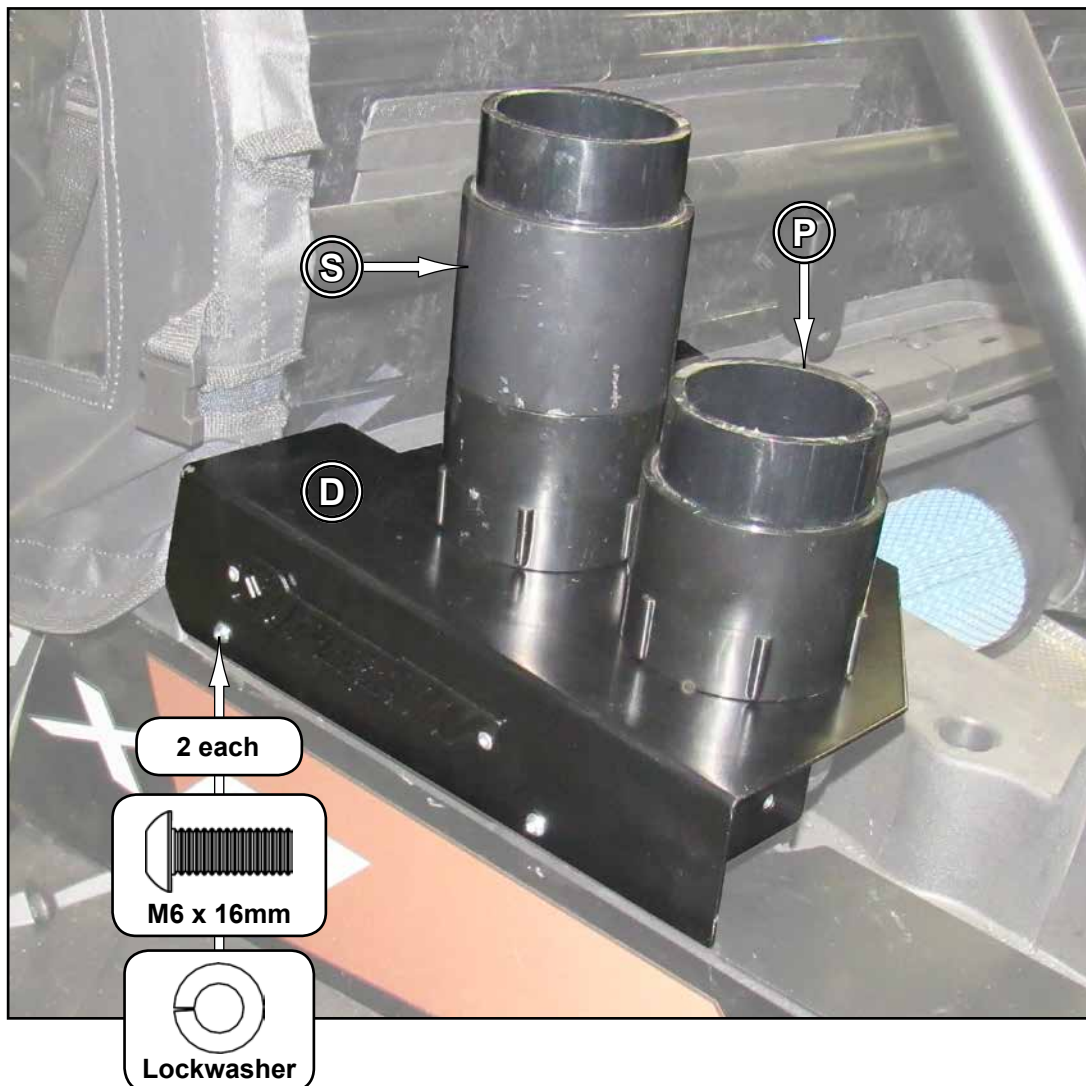



measure back 2-3/4"
and cut as shown



(finished cut)

- Reinstall stock Air Intake Hose.
- Replace stock Drain Plug with provided Air Intake Plug.



- Secure Air Intake Hose to Riser Pipe Assembly 2 (K) with Clamp.
- Use a lubricant on Hose to ease installation.



Belt Exhaust Assembly - Left

- Assemble Connectors shown; do not glue Pipes or Elbows at this time.

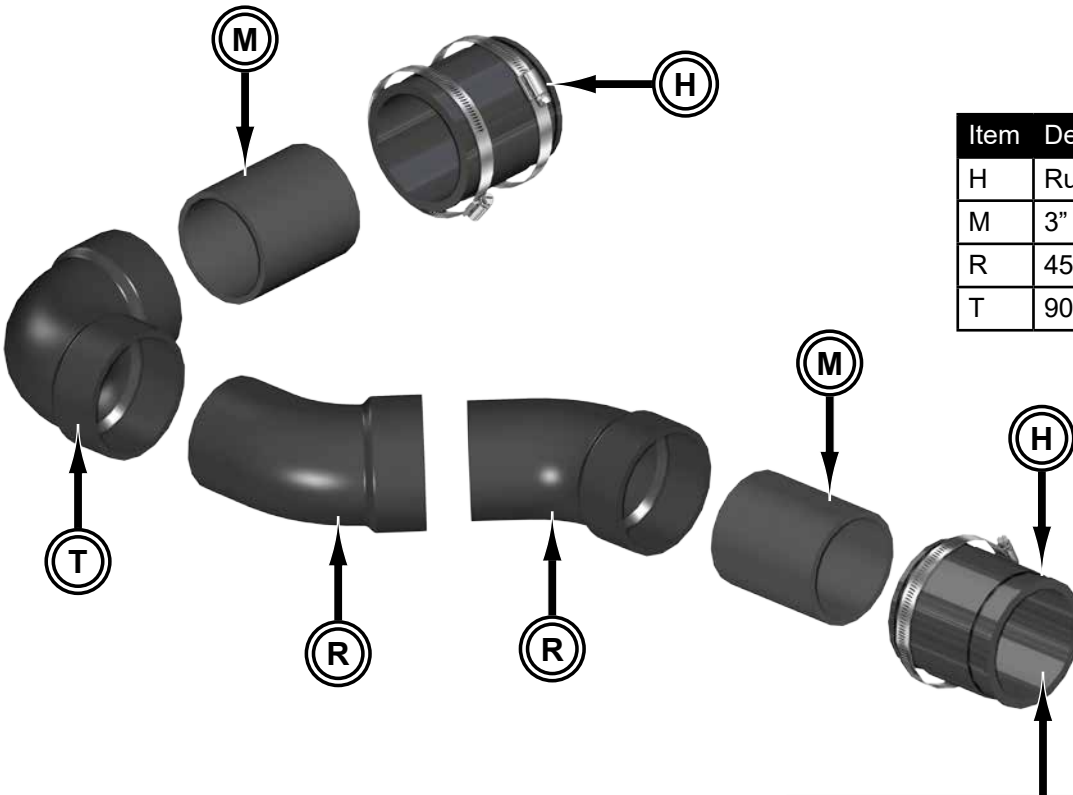

Item	Description
H	Rubber Connector x 2
M	3" Pipe x 2
R	45° Elbow x 2
T	90° Elbow

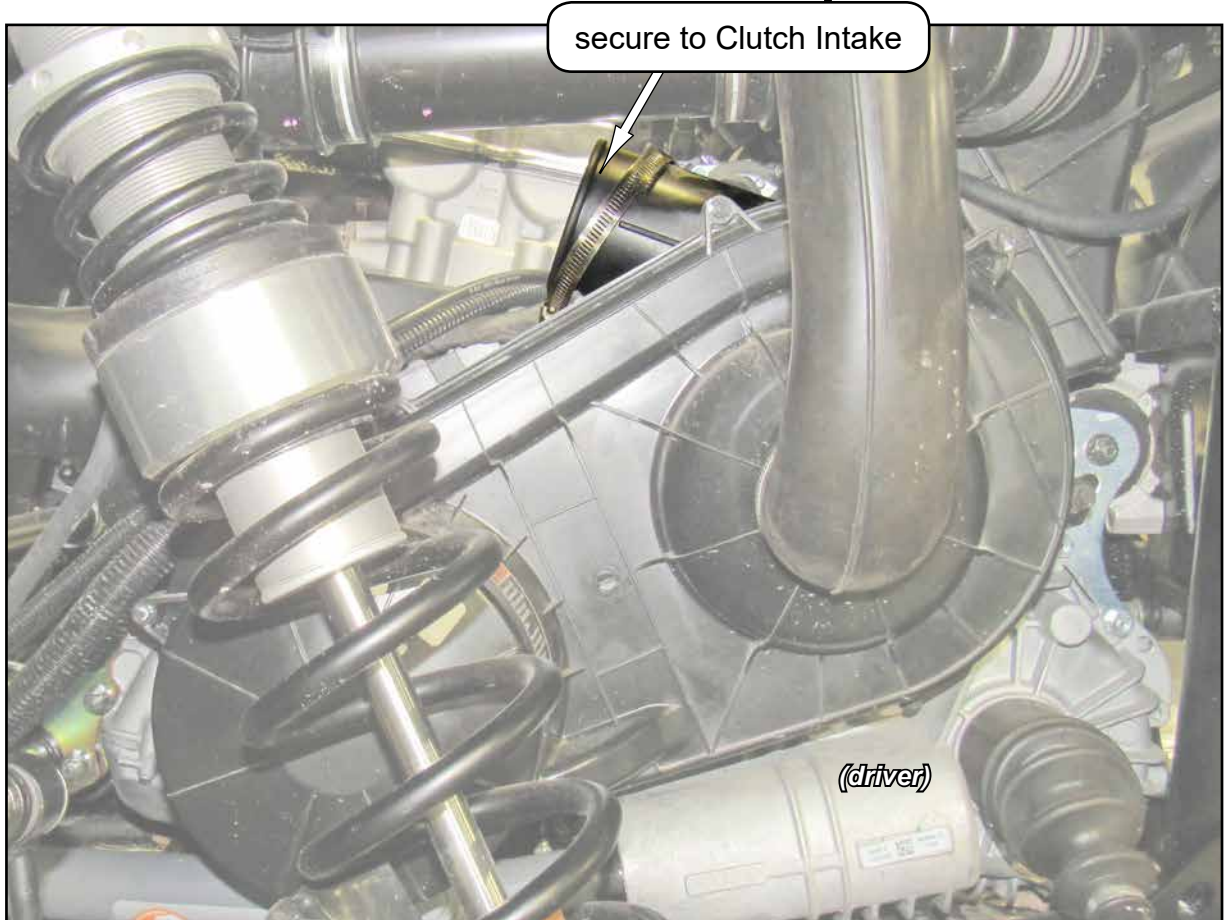

Belt Exhaust Assembly - Right

- Assemble Connectors shown; do not glue any components at this time.



secure to Rubber Connector (H)

Item	Description
H	Rubber Connector
L	Threaded Connector
N	17" Pipe
Q	6" Pipe
R	45° Elbow
T	90° Elbow
U	13-3/4" Pipe

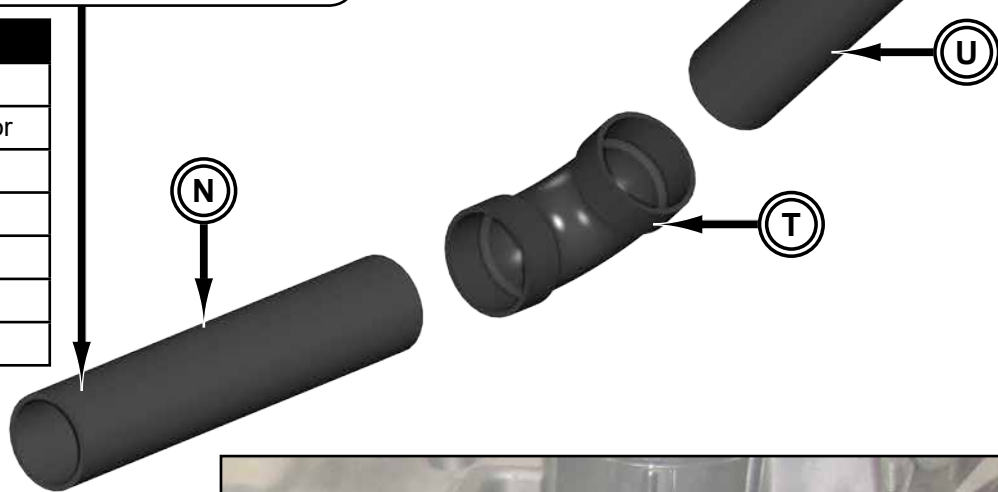

- After aligning all components of Belt Exhaust assembly, mark locations for plastic components requiring glue.
- Carefully remove Belt Assemblies and glue plastic components.



- Reinstall Belt Assemblies to machine.



- Install Passenger Riser Bracket (A) to Passenger Bracket (B) with hardware shown.
- Secure Riser Pipe Assembly 3 (S) and Snorkle Riser Pipe Assembly (P) to previously installed Riser Pipe Assemblies.

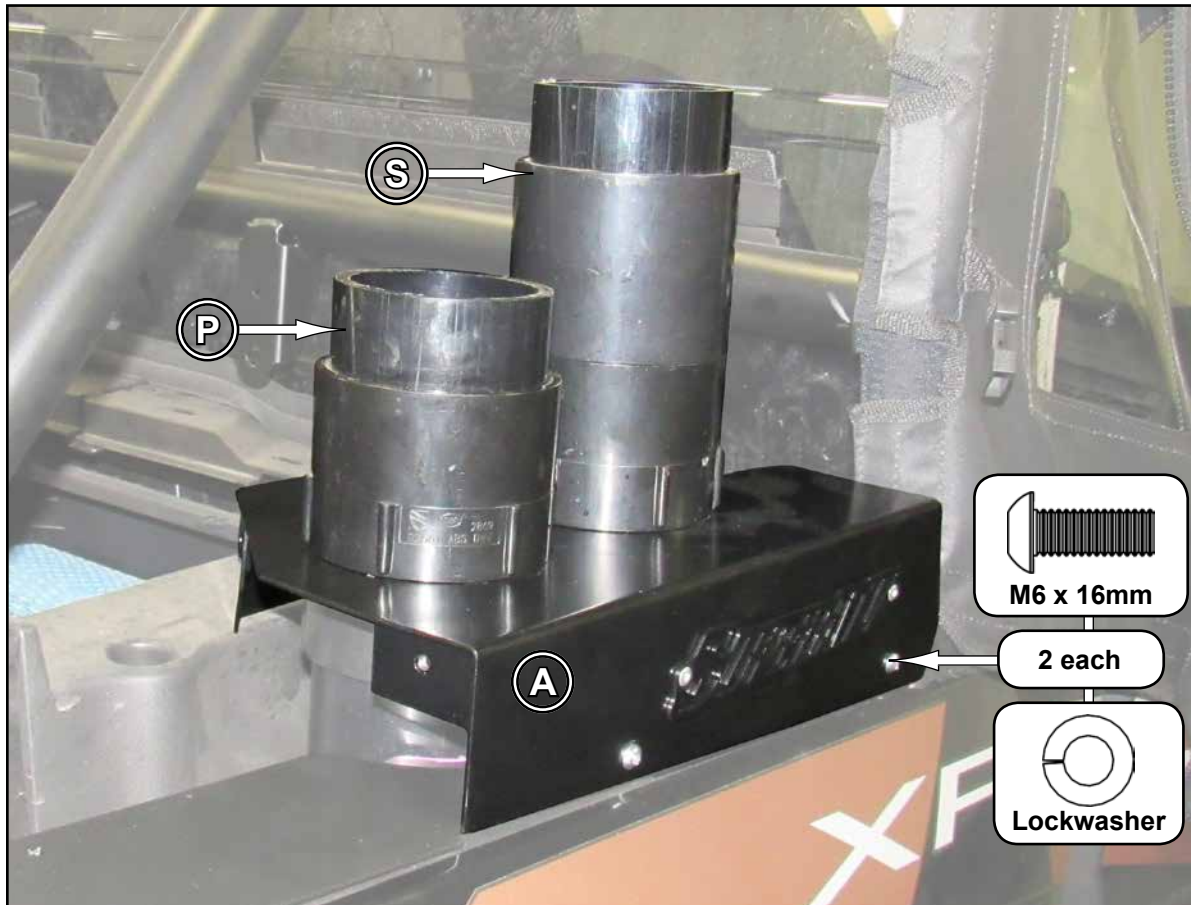

- Install Faceplates to Snorkel Risers (Z) with hardware shown.

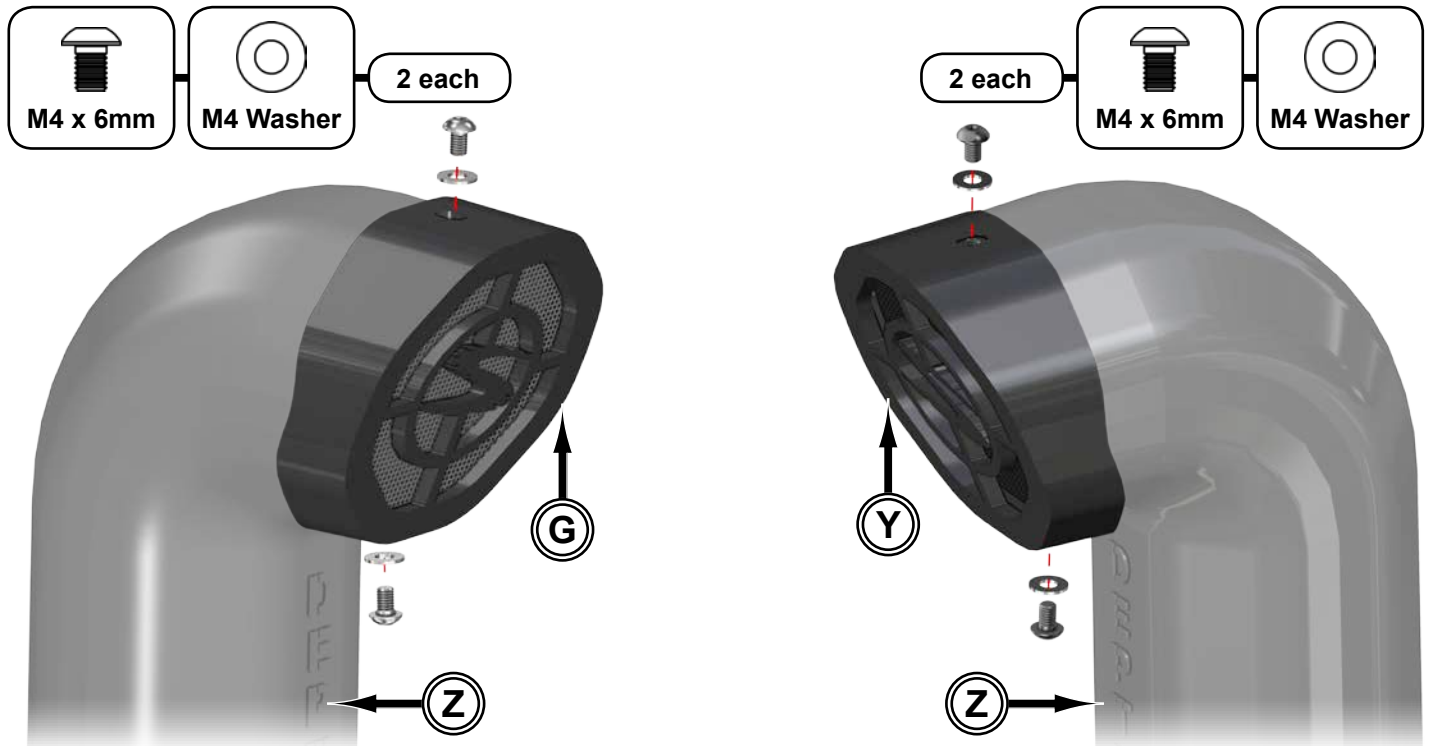

- Apply black RTV 100% Silicone to Riser Pipe Assemblies (Z) and install.

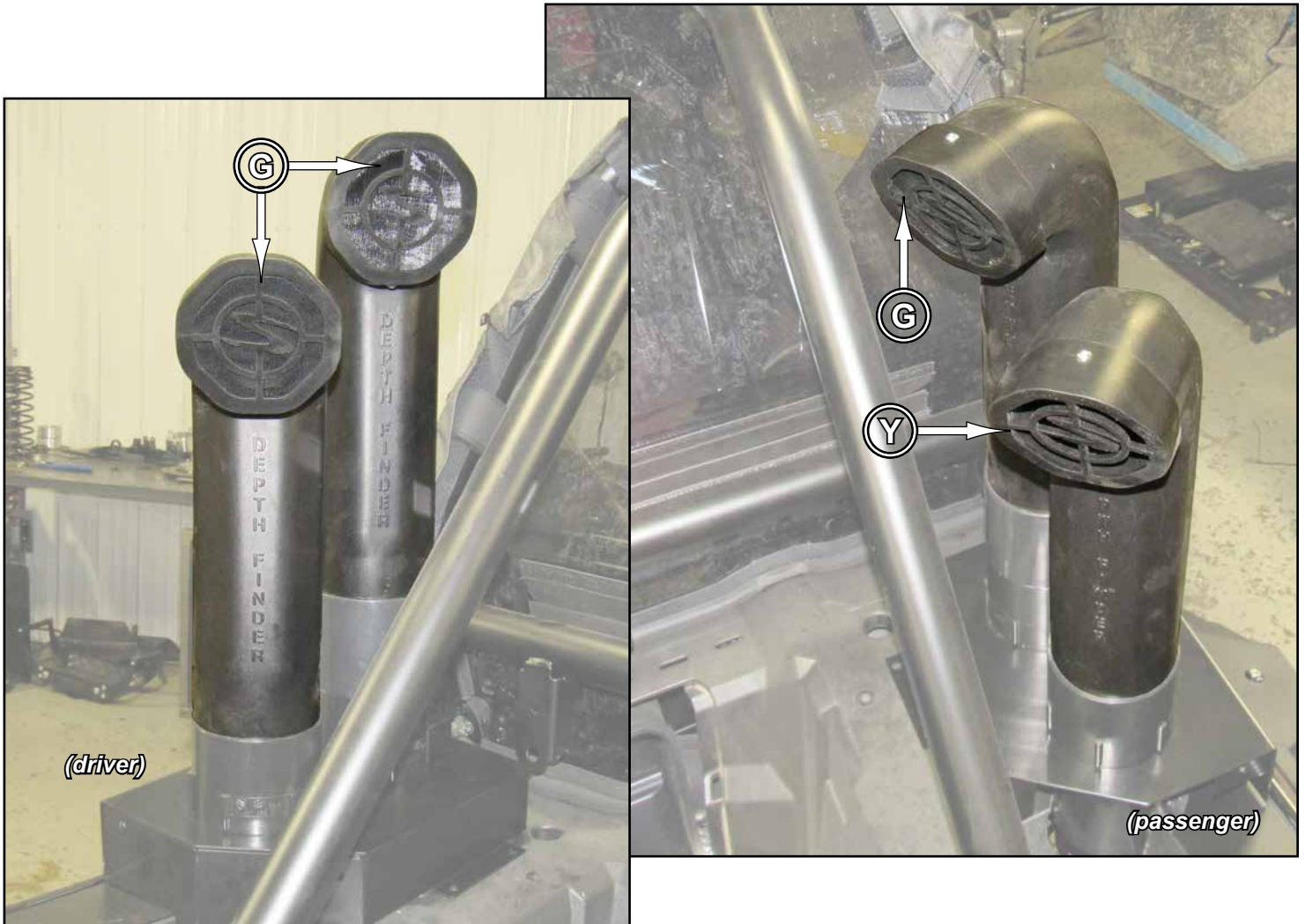

- Install Clip Nuts to Support Plates (CC).

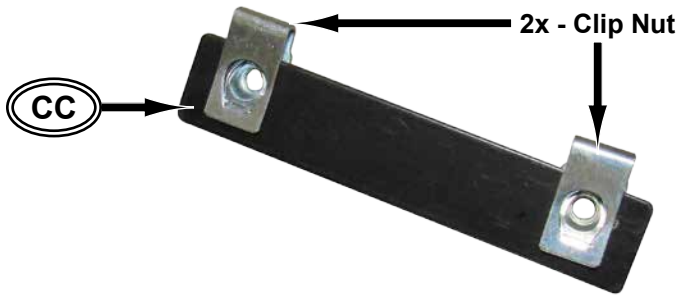

- Secure Passenger Riser Bracket (A) to plastic and Support Plate (CC) with hardware shown.
- Repeat for Driver Riser Bracket (D).

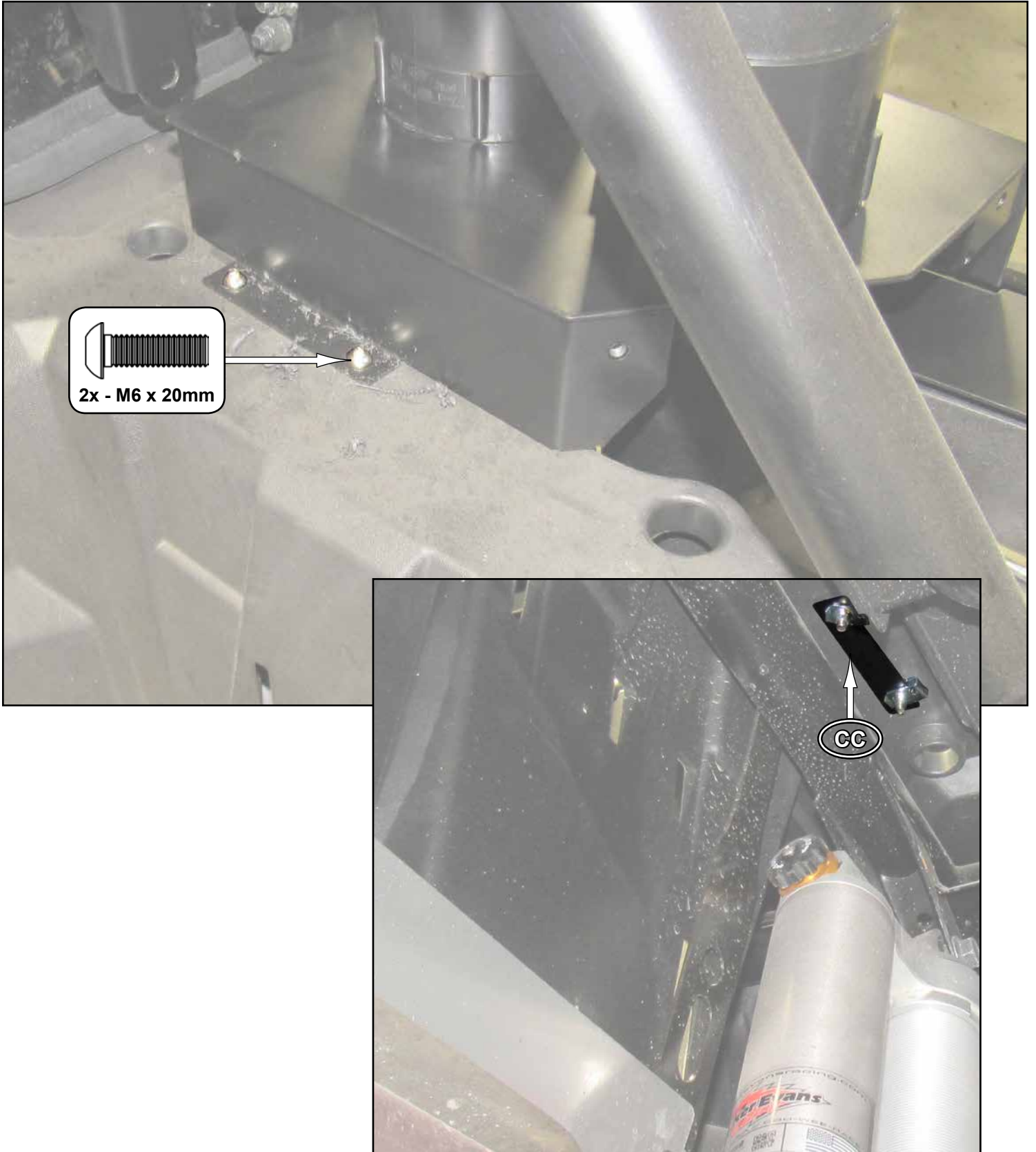

- Secure Passenger Rear Plate (C) to Passenger Riser Bracket (A) with hardware shown.
- Repeat for Driver Rear Plate (F).

