

(kit contents continue on following page)

Item	Description	Item	Description
A	Upper A-Arm, Right	E	Tie Rod Kit
B	Lower A-Arm, Right	F	Right Front Shock Bracket
C	Upper A-Arm, Left	G	Left Front Shock Bracket
D	Lower A-Arm, Left		

Need help with your installation?

 sales@superatv.com
 www.superatv.com

 1-855-743-3427
  8:00am - 8:00pm EST M-Th
 8:00am - 7:00pm EST Friday
 9:00am - 2:00pm EST Saturday

Read instructions and view illustrations before beginning.

Thank You
For Choosing
SUPERATV.COM[®]

(kit contents continued)

Item	Description	Qty
H	Brake Line Clamp	2
J	Brake Line Clip	8
K	Grease Fitting	8
L	Brake Lines <i>(See Chart)</i>	-
M	Left Swingarm	1
N	Right Swingarm	1
Q	Spacer	2

Brake Lines (L)

Location	Length (Approx)
Right Rear	43-5/16"
Front Right	30"
Front Left	40"

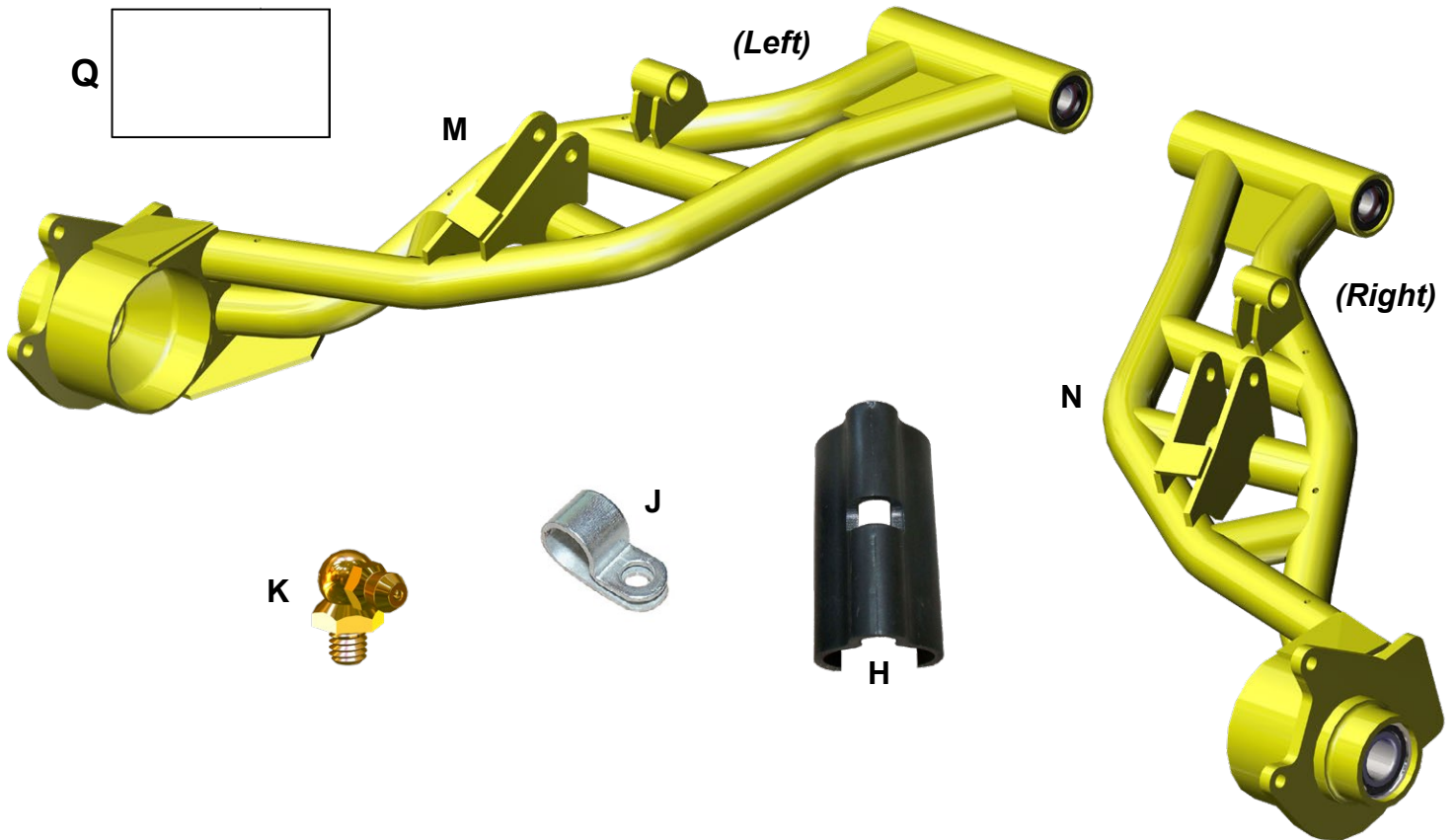

(some hardware may remain after installation)

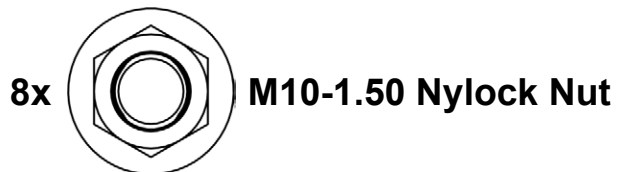
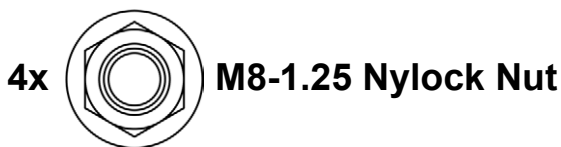

Front Removal: *Keep all components removed from machine.*

- Raise front of machine off ground and secure with jack stands.
- Remove Inner Fenders and hardware from Front Guard Plate.
- Remove Shocks.
- Remove Brake Lines and Calipers.
- Remove Tie Rods from Knuckles and Pitman Arm.
- Remove A-Arms from Frame.
- Remove Axles.

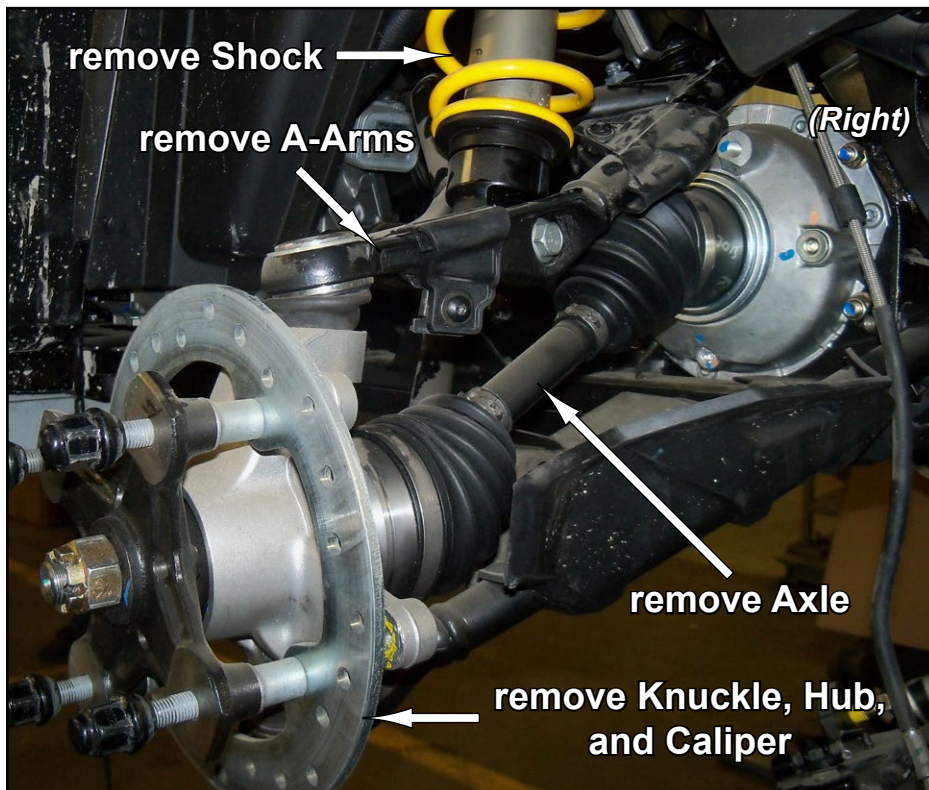
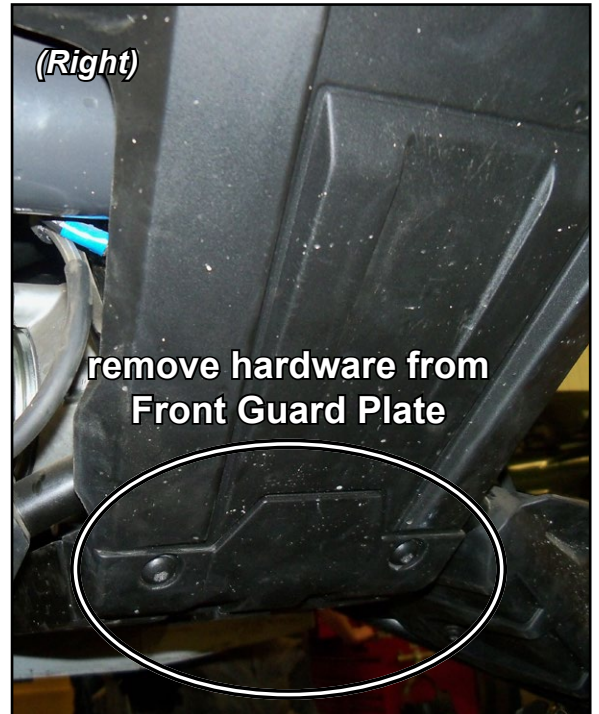
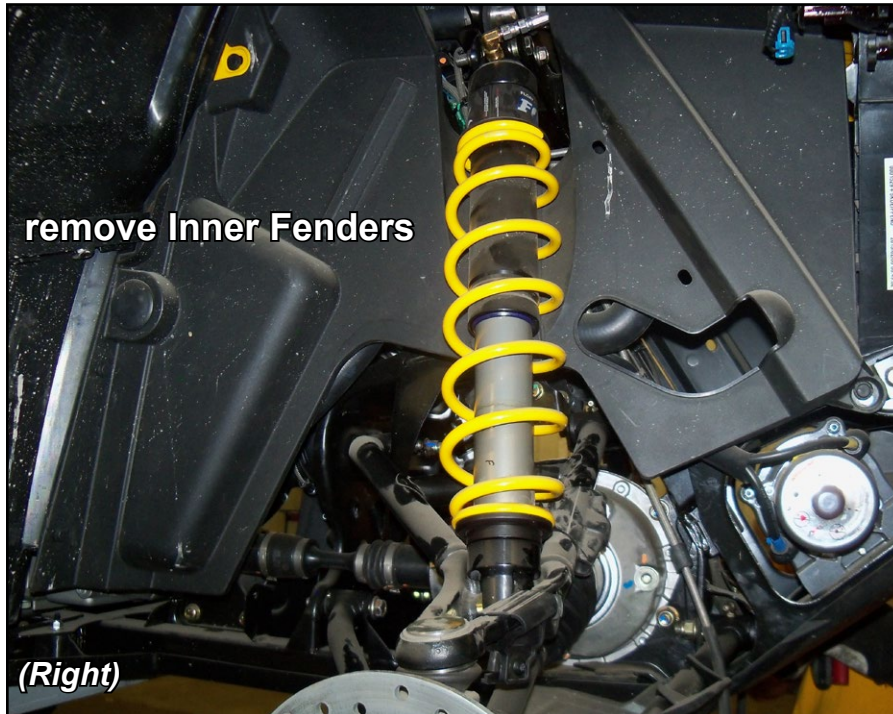

(Front Removal continue illustrations on following page)

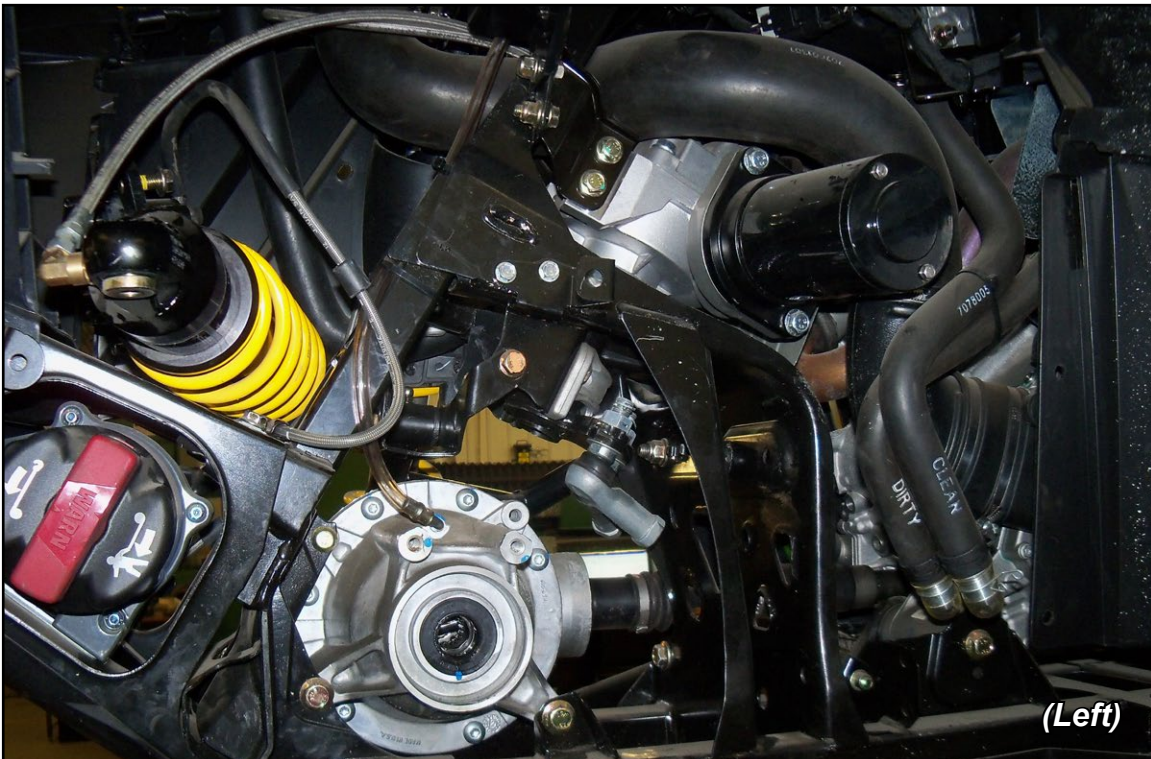
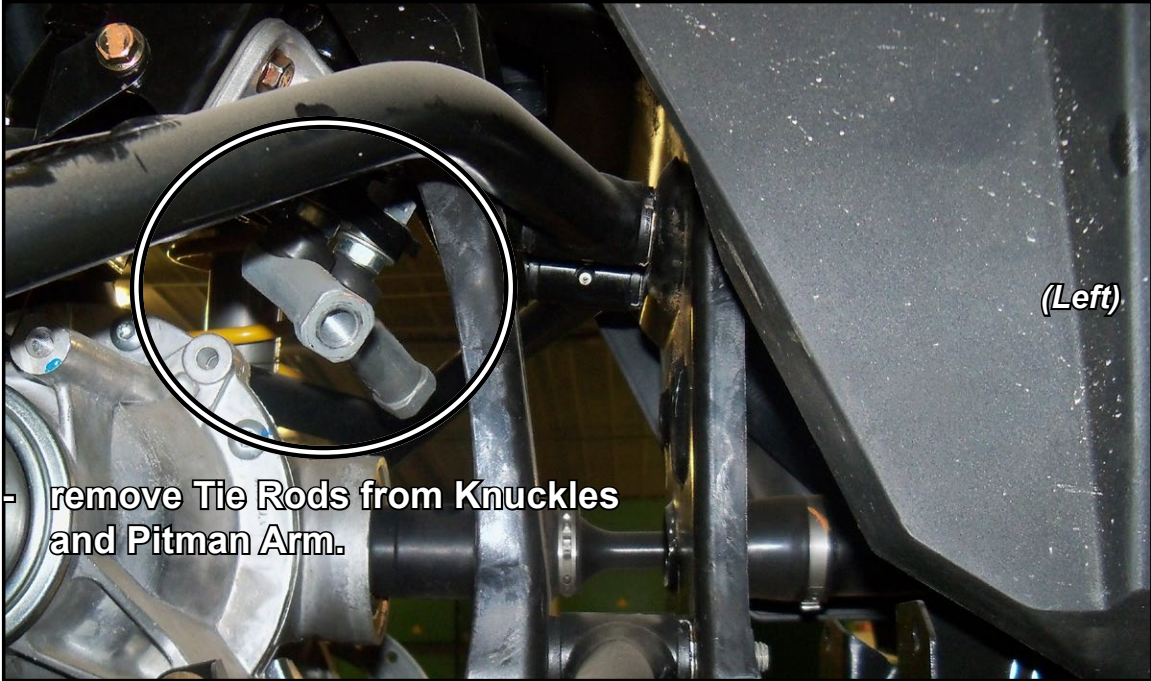
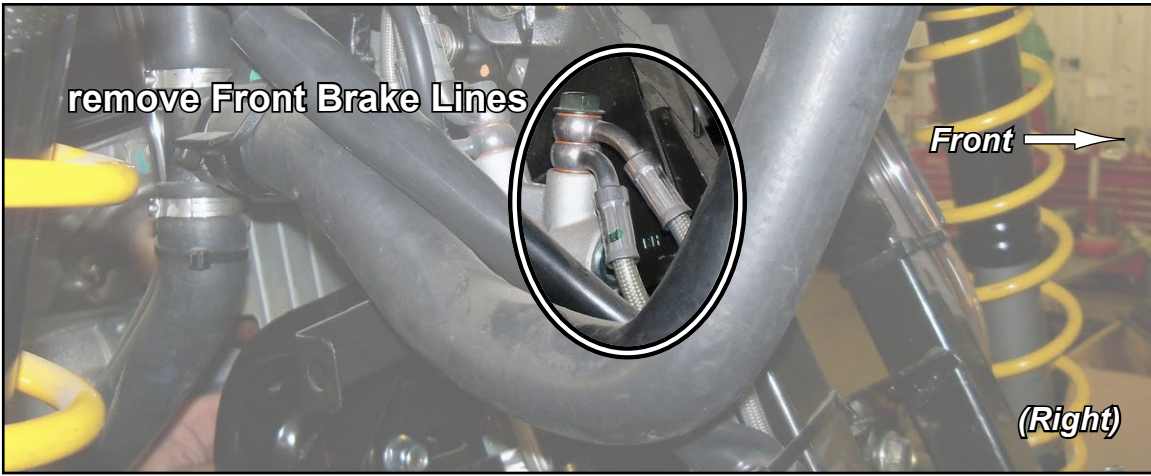

Front A-Arms Preparation

- If not present, install Grease Fittings (K) into A-Arms (A-D).
- Install stock Bushings, Wear Plates, and Cushions to new A-Arms.
- Transfer stock Ball Joints to new A-Arms.
- Adjust Pivot Blocks in Lower A-Arms (B)(D).
- Set A-Arms aside.

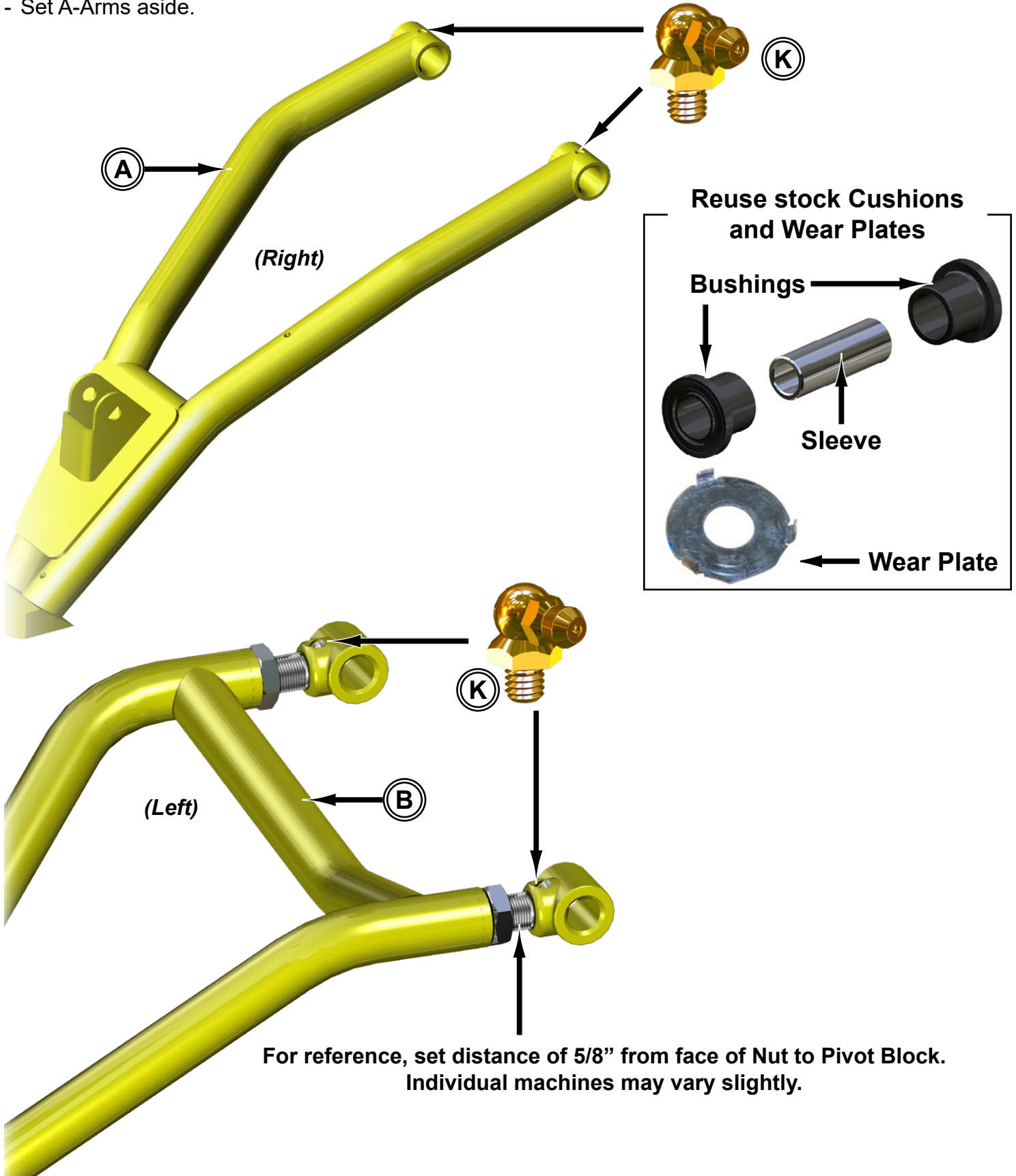

Front Installation: *Do not tighten hardware completely unless noted.*

- Remove hardware shown and install Front Shock Brackets (F)(G) with hardware shown.

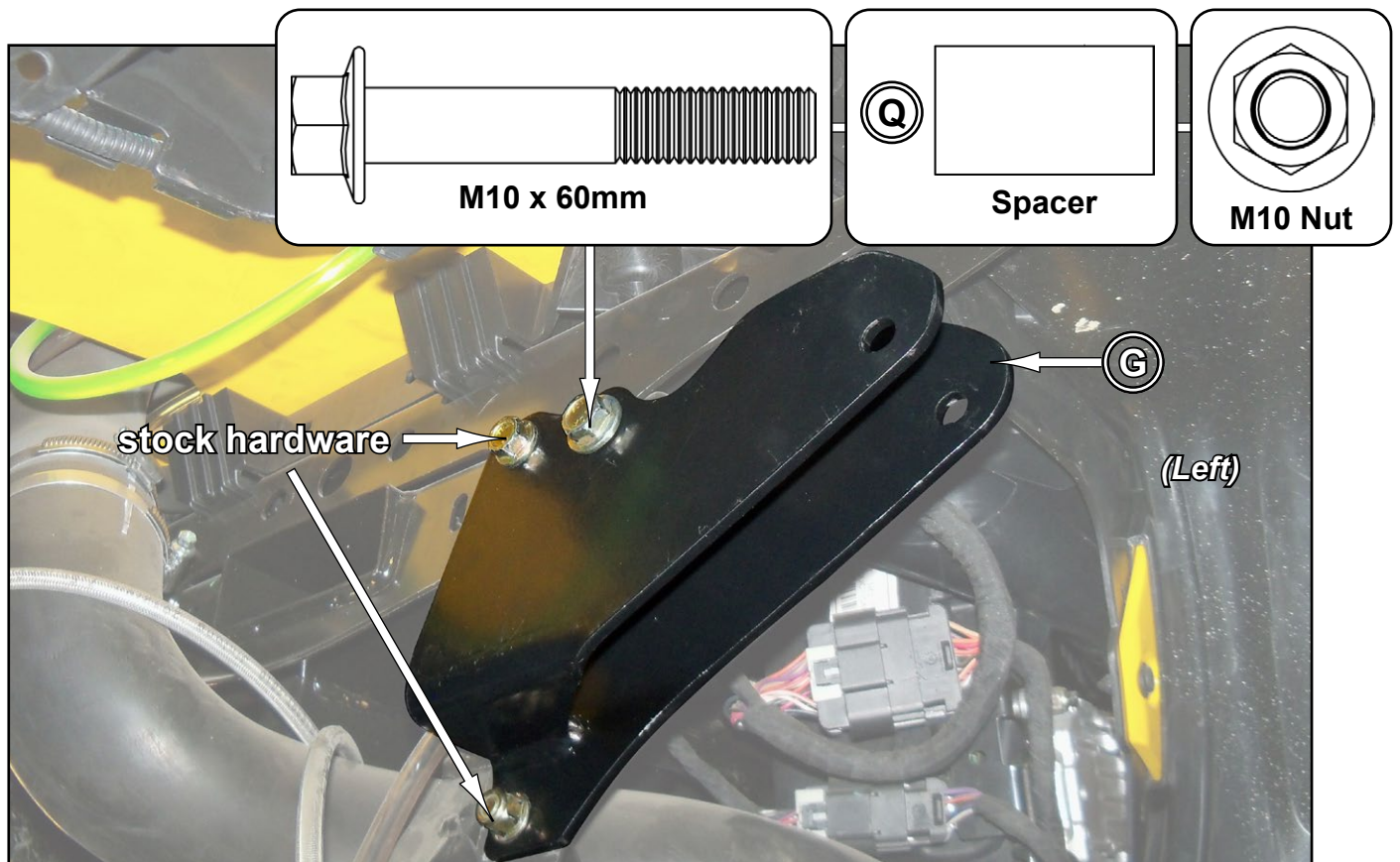
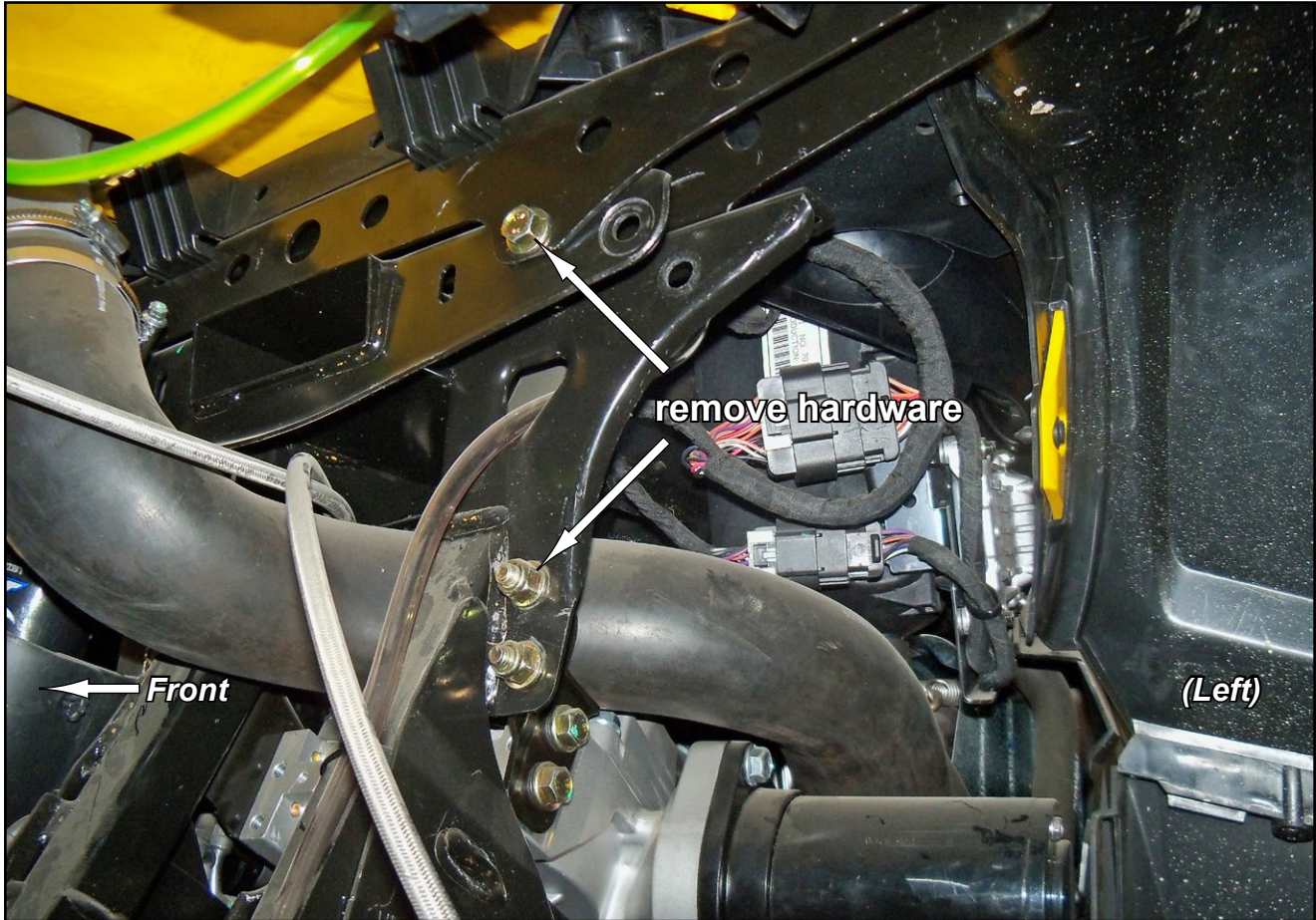

Front Installation continued:

- Install A-Arms (A-D) to Frame with stock hardware. SuperATV recommends using Loc-Tite on Nuts when installing.
- Install new Axles.



- Repeat steps for opposite.
- Install new Tie Rods (E) to Knuckles and Pitman Arm. See following page.

Tie Rod installation

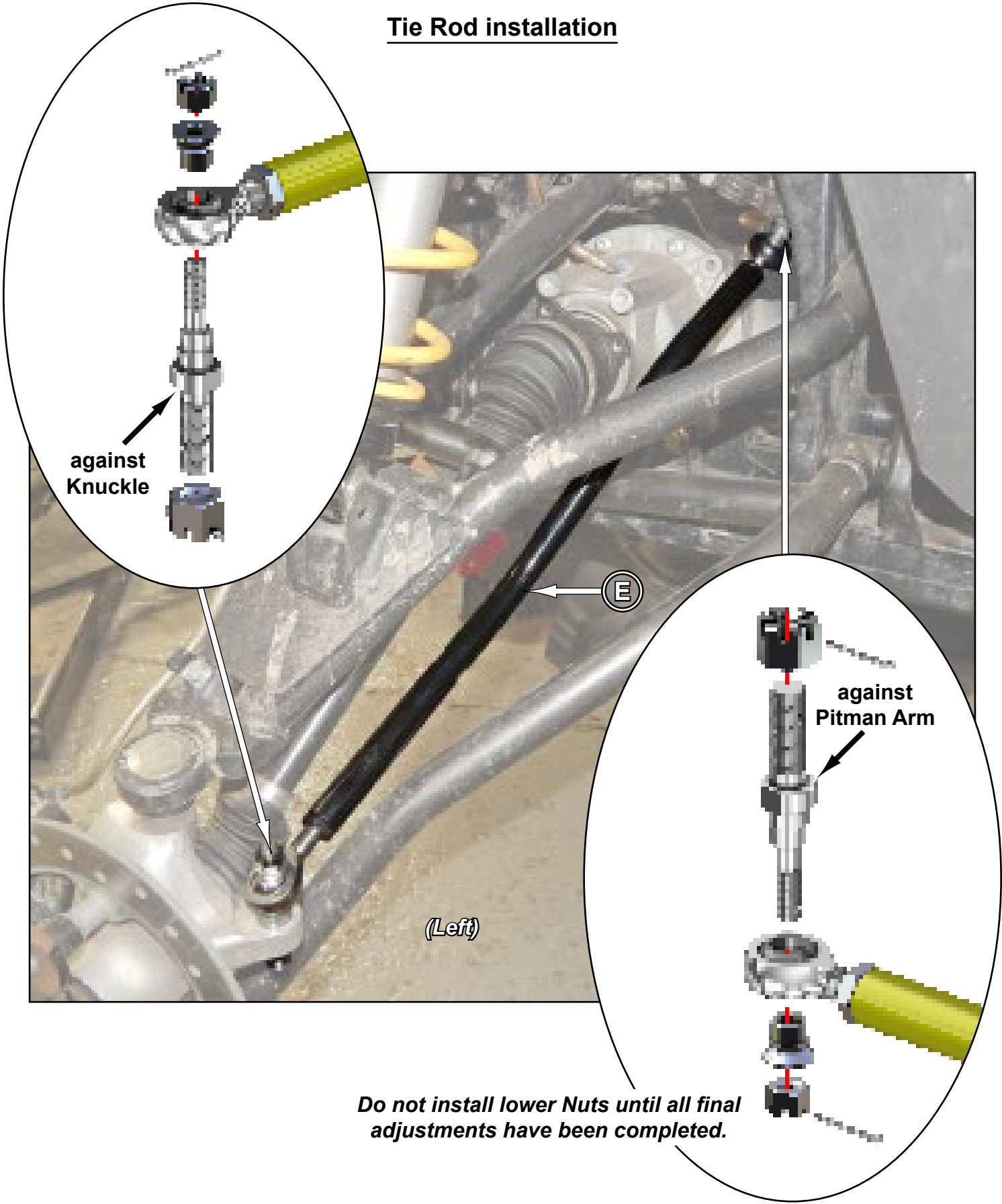

Front Installation continued:

- Install Shocks to Front Shock Brackets (F)(G) with hardware shown. Secure to Upper A-Arms (A)(C) with stock hardware.

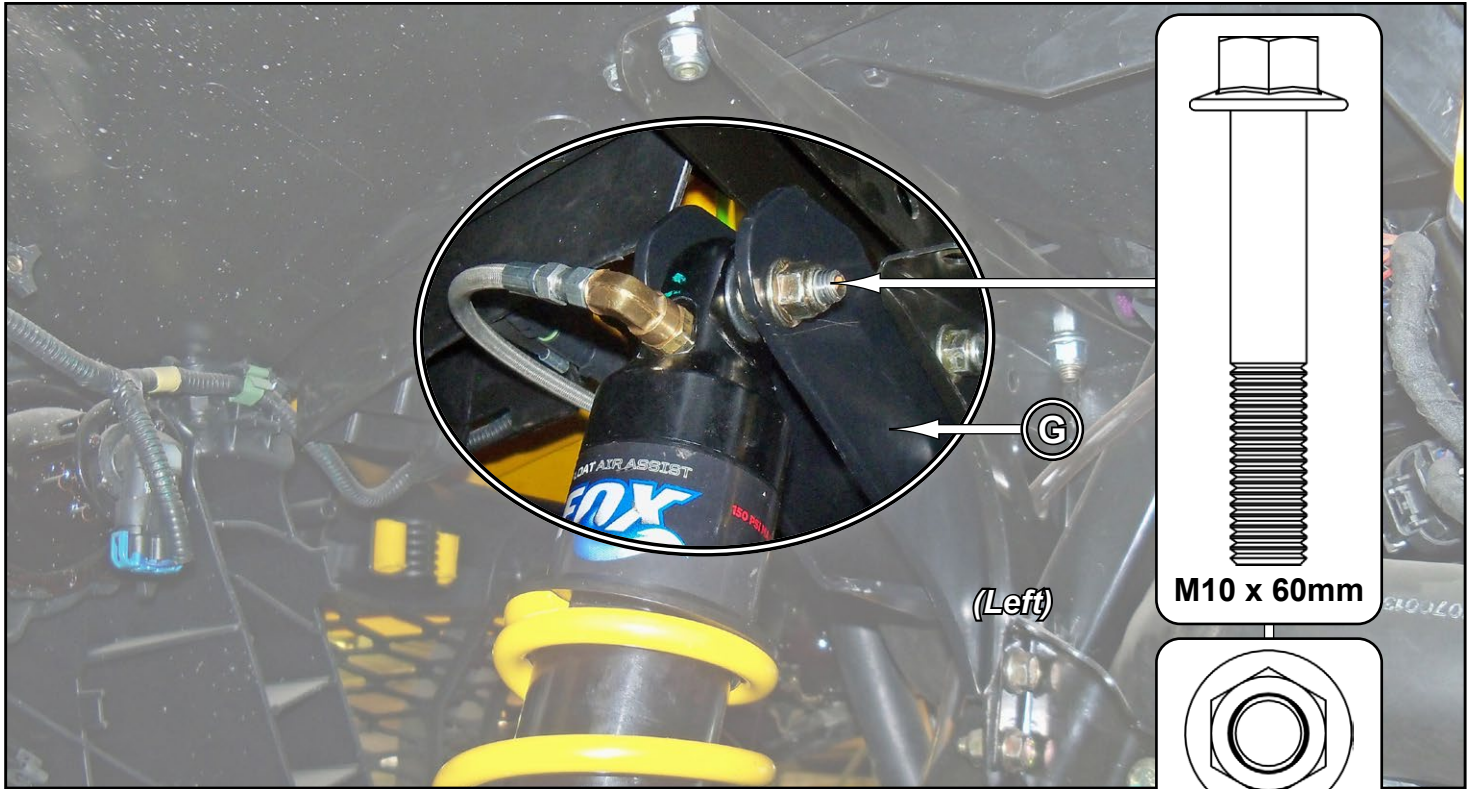

M10 x 60mm

M10 Nut

- Install Front Brake Lines:
- Follow stock routing when installing.
- Brake Line Fitting does not require mounting hardware; use a Wire-Tie if desired.
- Secure to Upper A-Arms with Brake Line Clips (J), Brake Line Clamps (H), and provided hardware.
- Ensure no binding or interference can occur when in use.

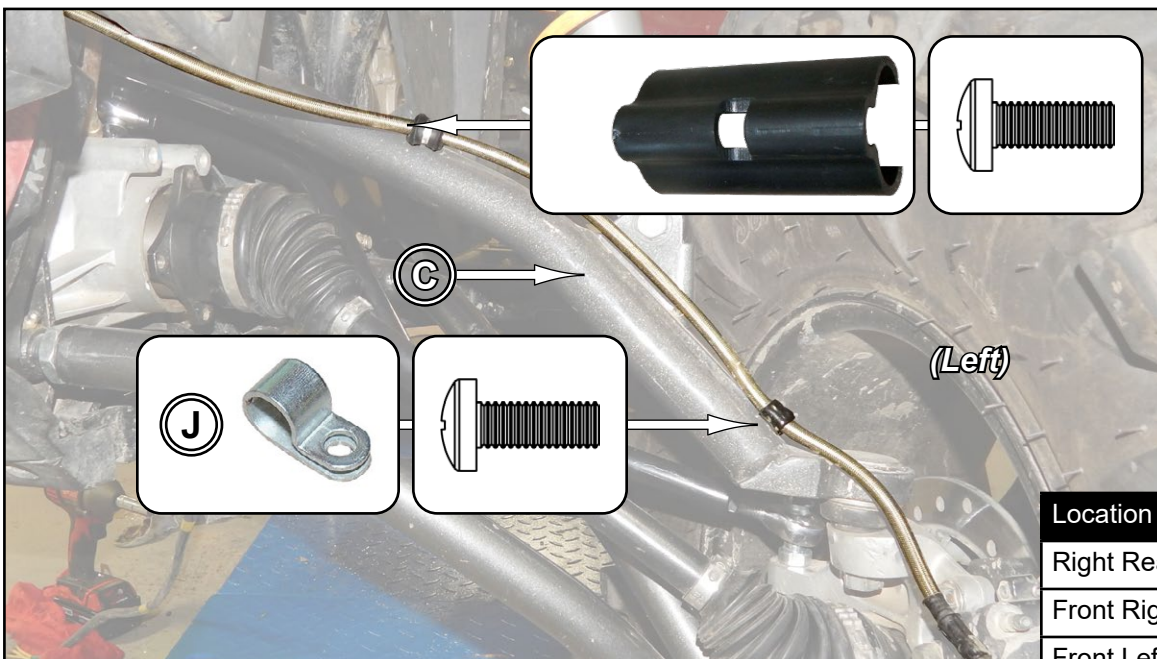

Location	Length (Approx)
Right Rear	43-5/16"
Front Right	30"
Front Left	40"

- Reinstall necessary components and tighten all hardware completely.

Rear Removal: *Keep all components removed from machine.*

- Raise rear of machine off ground and secure with jack stands.
- Remove Wheels, Caliper, and Brake Line.
- From Swing Arms remove Shocks and Swaybar Linkages.
- Remove Swing Arms. (Only **outer** most Spacers will be used when installing new Swing Arms. Ball Bearings, Seals, and inner Spacers are included and pre-assembled in new Swing Arms).
- Leave Axial Pivot in place.
- Remove Axles.

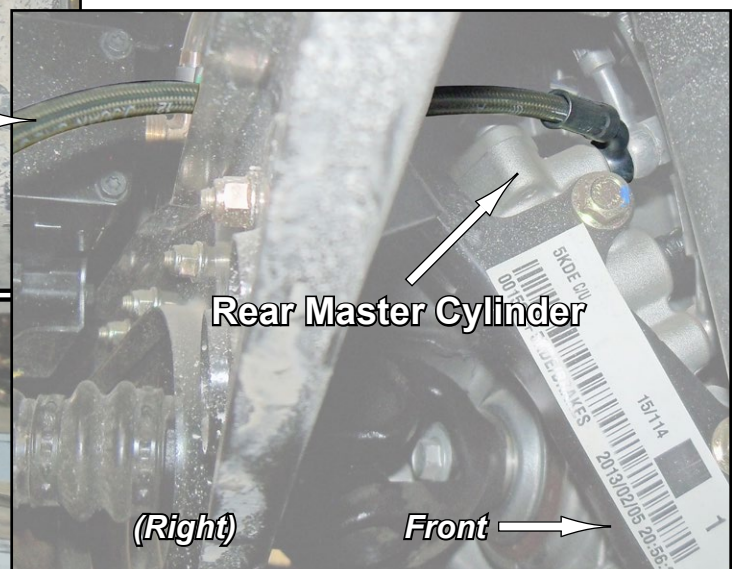
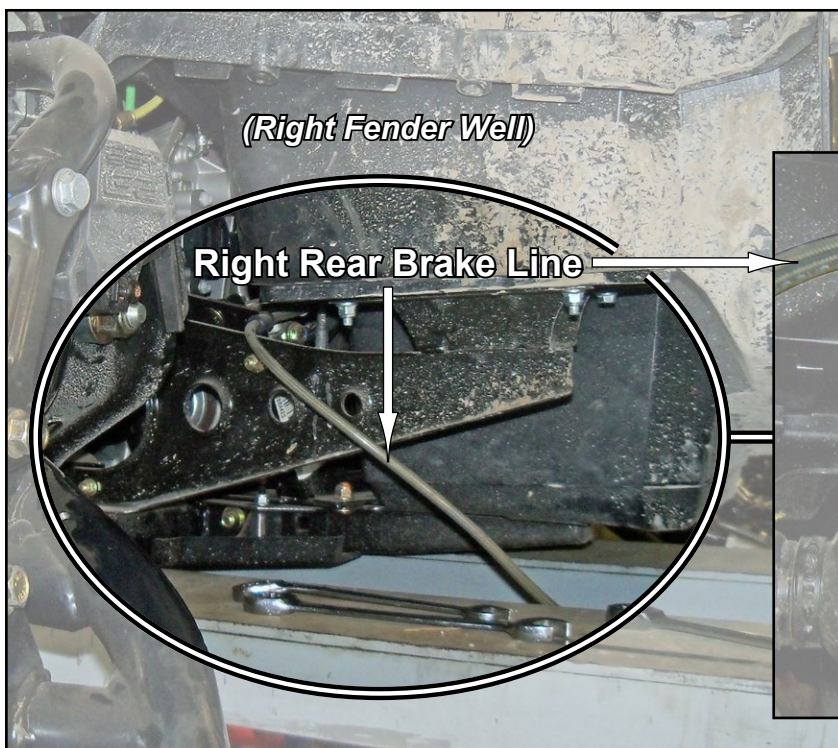
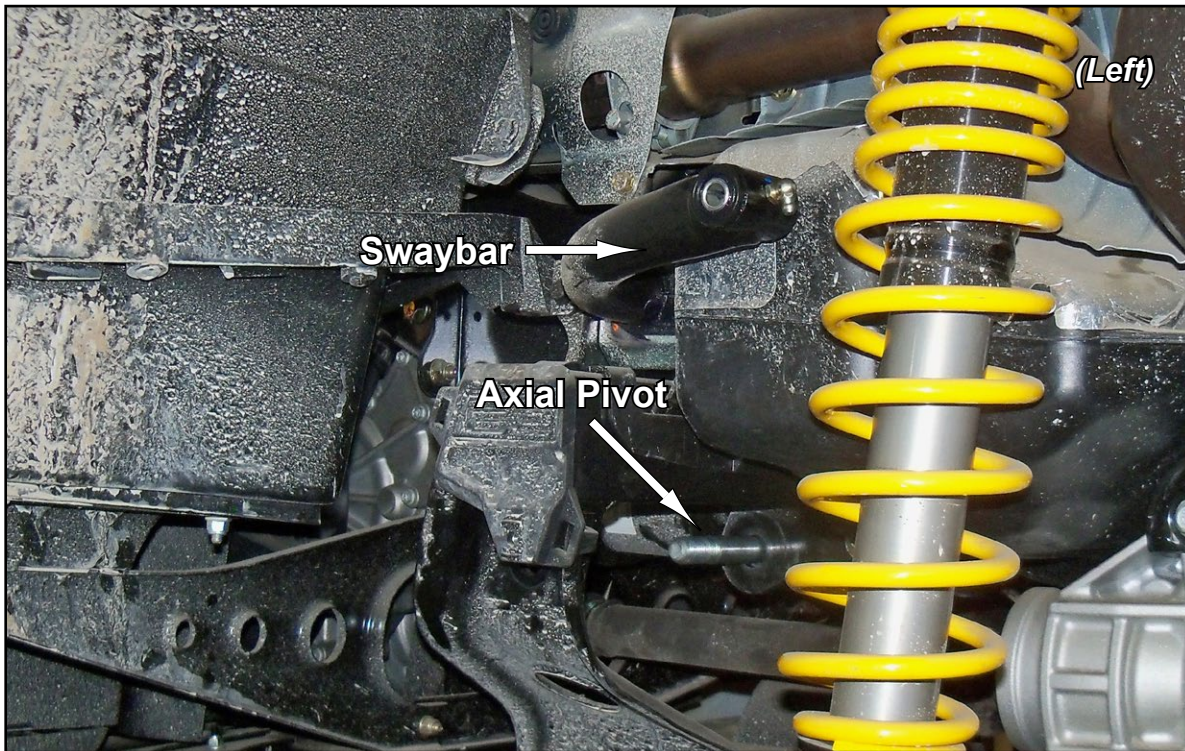

Rear Installation: *Do not tighten hardware completely unless noted.*

- Install new Axles.
- Install Swing Arms (M)(N) onto Axial Pivot and secure with stock hardware and Outer Spacers.
- Reinstall Sway Bar Linkages and Shocks to Swing Arms (M)(N) with stock hardware. SuperATV recommends using Loc-Tite on Nuts when installing.

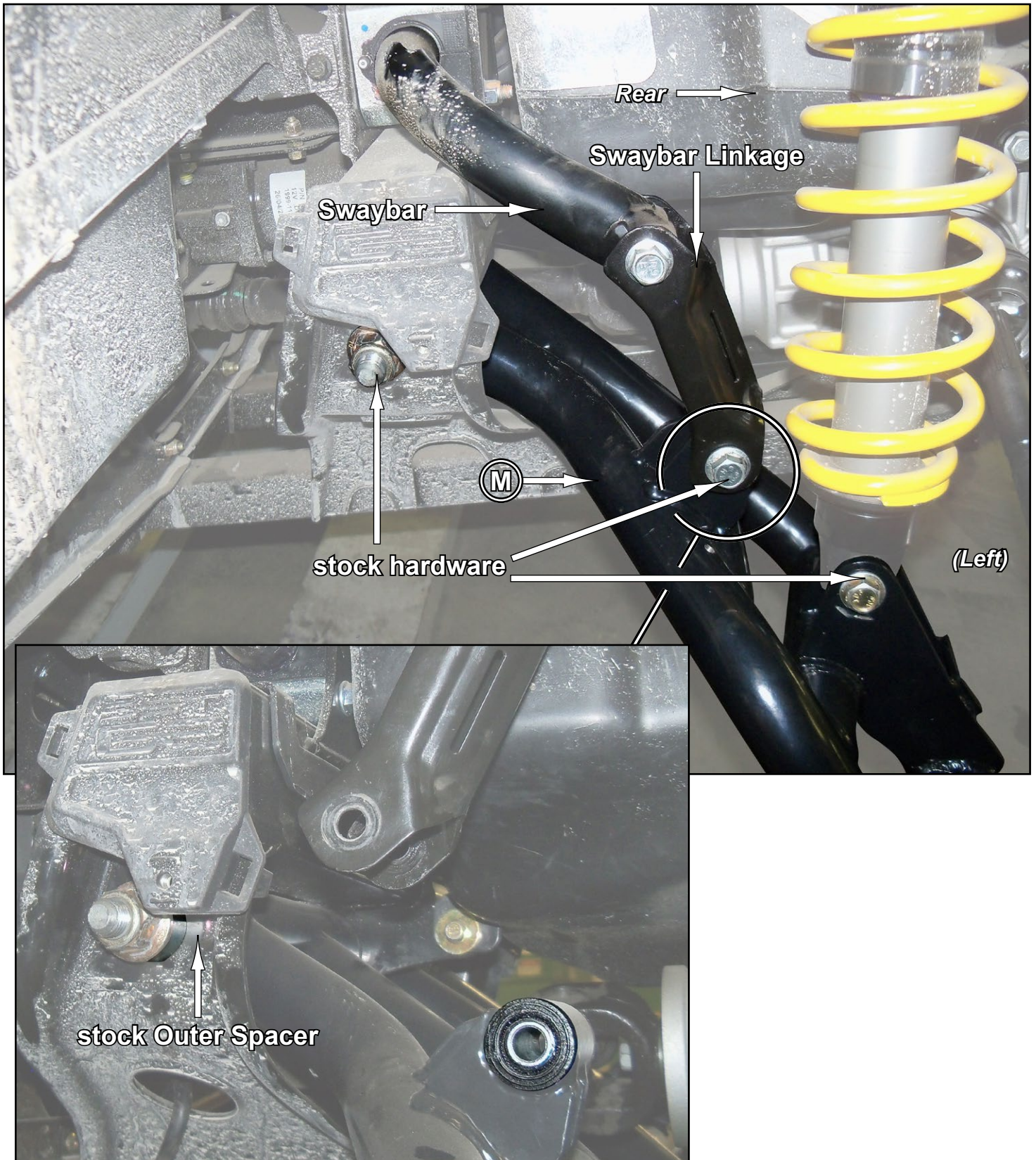

- Install Rear Brake Lines:
- Follow stock routing when installing.
- Secure to Swing Arm (N) with Brake Line Clips (J) with provided hardware.
- Ensure no binding or interference can occur when in use.

Location	Length (Approx)
Right Rear	43-5/16"
Front Right	30"
Front Left	40"

Rear Brake Lines have different style fittings at each end.

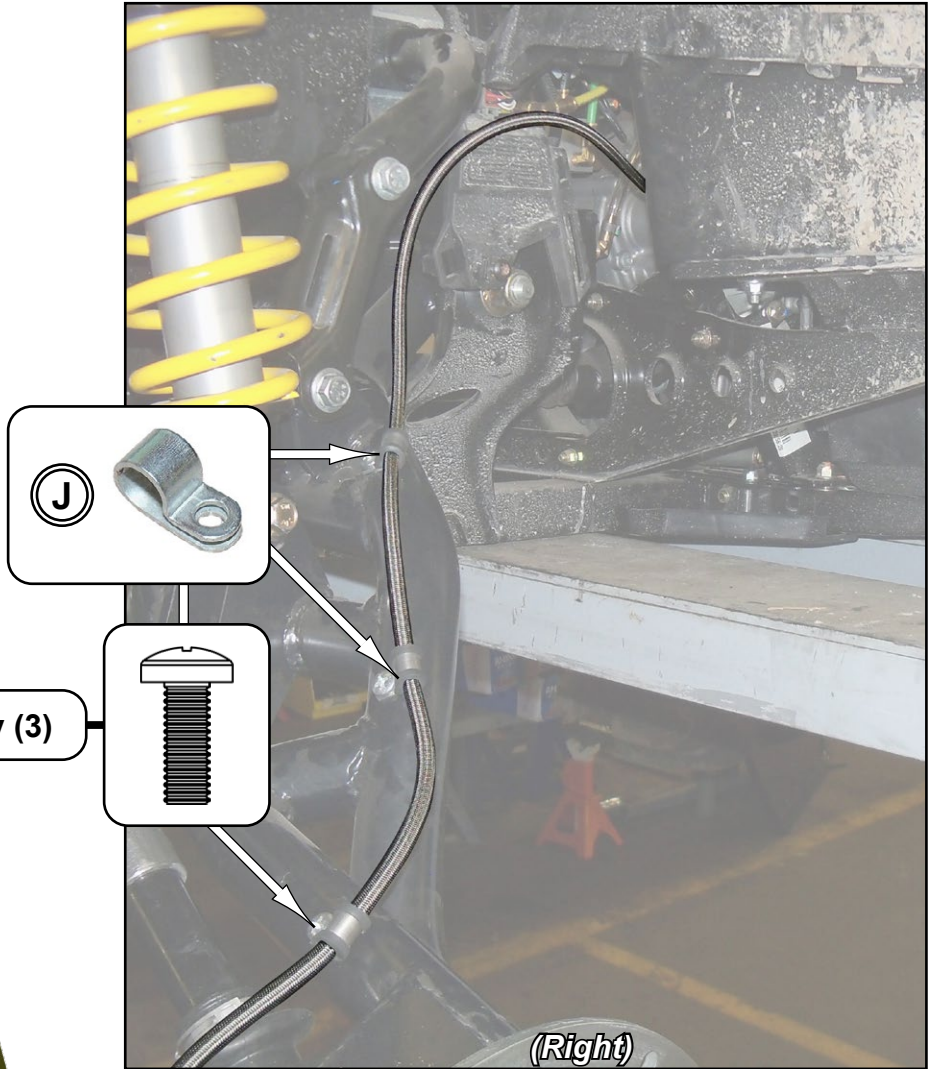
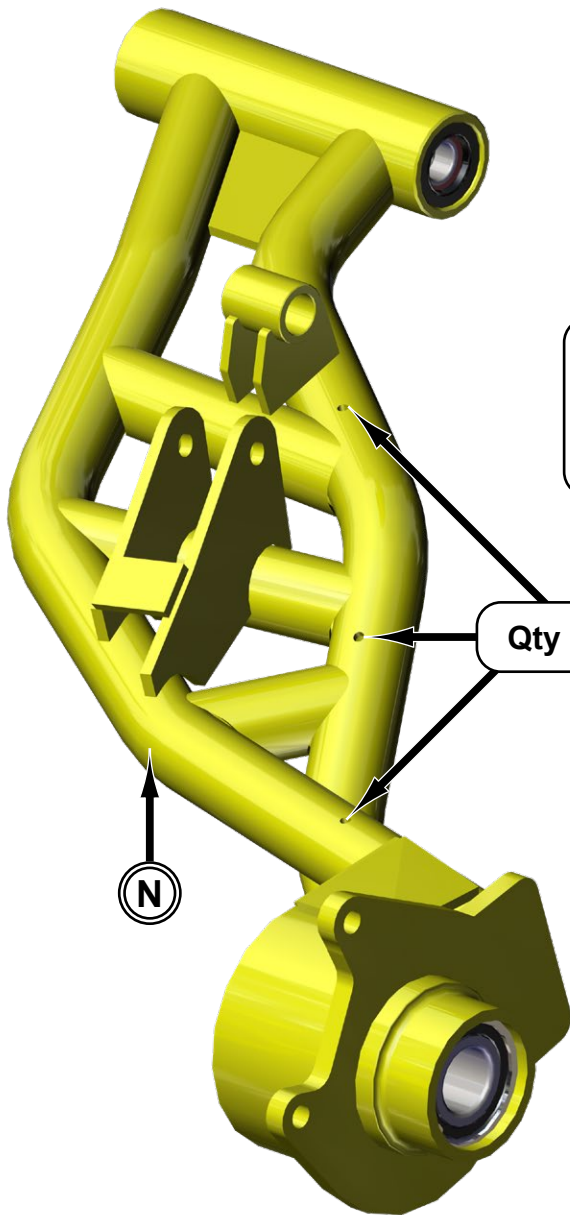

- Reinstall necessary components with stock hardware.
- Tighten all hardware completely.
- Replace Brake Fluid and bleed Brake Lines.

CAMBER

- Tires must have equal air pressure before making adjustments.
- Adjustments to be made after all suspension components have been completely assembled.
- Tires must not be in contact with ground when making adjustments.
- Perform adjustments in small increments.



Adjusting Camber:

- Remove A-Arms from Frame and turn Pivot Blocks to adjust camber. Reinstall Arms.
- Lower machine and settle suspension components by rolling machine back and forth several feet at a time.
- Check settings and make small adjustments as needed.
- Each time an adjustment is made, machine must be rolled back and forth to settle suspension components.
- Once desired setting is achieved, tighten hardware completely. Loc-tite on Nuts is recommended.

A NEGATIVE CAMBER SETTING OF 1° to 2° IS RECOMMENDED.

LOWER:

Too much positive camber: adjust Pivot Blocks **OUT**.

Too much negative camber: adjust Pivot Blocks **IN**.

note: 2 full turns is 1°

UPPER A-ARMS:

Too much positive camber: adjust Pivot Blocks **IN**.

Too much negative camber: adjust Pivot Blocks **OUT**.

note: 2 full turns is 1°

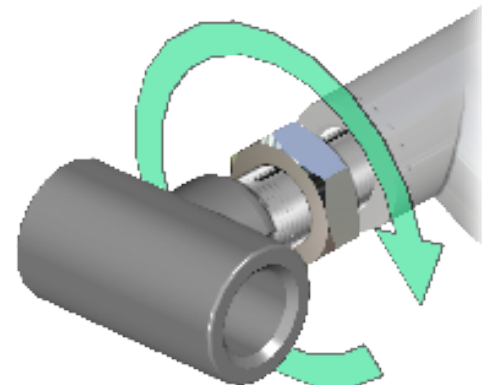

Liability Statement

SuperATV's® products are designed to best fit user's ATV/UTV under stock conditions. Adding, modifying, or fabricating any factory or aftermarket parts will void any warranty provided by SuperATV® and is not recommended. SuperATV's® products could interfere with other aftermarket accessories. If user has aftermarket products on machine, contact SuperATV® to verify that they will work together.

Although SuperATV® has thousands of satisfied customers, user should be aware that installing lift kits, long travel, or suspension kits, tires, etc. will change the ride of machine and may increase maintenance and part wear. Operating any off-road machine while, or after, consuming alcohol and/or drugs increases risk of bodily harm or death. No warranty or representation is made as to this product's ability to protect user from severe injury or death. SuperATV® urges operators and occupants to wear a helmet and appropriate riding gear at all times.

By purchasing and installing SuperATV® products, user agrees that should damages occur, SuperATV® will not be held responsible for loss of time, use, labor fees, replacement parts, or freight charges. SuperATV®, nor any 3rd party, will not be held responsible for any direct, indirect, incidental, special, or consequential damages that result from any product purchased from SuperATV®. The total liability of seller to user for all damages, losses, and causes of action, if any, shall not exceed the total purchase price paid for the product that gave rise to the claim.

SuperATV® will warranty only parts provided by SuperATV®. Any damage or problems with OEM housings, bearings, seals, or other manufacturers' products will not be covered by SuperATV®. SuperATV® parts and products are not warrantied if item was not installed properly, misused, or modified.

Installing, adding, modifying, or fabricating any factory or aftermarket product to your ATV/UTV may violate certain local, state, and federal laws. Be advised that laws vary depending on town, city, county, state, etc. Use of certain products on public streets, roads, or highways may be in violation law. The Buyer is solely and exclusively legally and personally responsible for any violation of the law by the installation or use of the product. You must abide by all local, state, and federal laws, including but not limited to vehicle safety, traffic laws, and ordinances. It is your responsibility to know the laws and how they apply to you.

The Buyer is responsible to fully understand the capability and limitations of his/her vehicle according to manufacturer specifications, warnings and instructions and agrees to hold SuperATV® harmless from any damage resulting from failure to adhere to such specifications, warnings and/ or instructions. The Buyer is also responsible to obey all applicable federal, state, and local laws and ordinances when operating his/her vehicle while using this product, and the Buyer agrees to hold SuperATV® harmless from any violation thereof.