

**INSTALLATION INSTRUCTIONS**  
**3" - 5" Adjustable Lift Kit:**  
**for Polaris RZR<sup>®</sup> XP 1000**

Item	Description
A	Front Bracket
B	Rear Bracket, Passenger
C	Rear Bracket, Driver
D	Rear Spring Spacer x 2

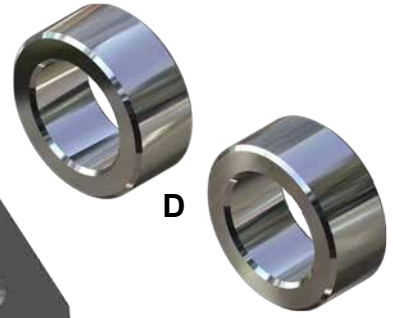
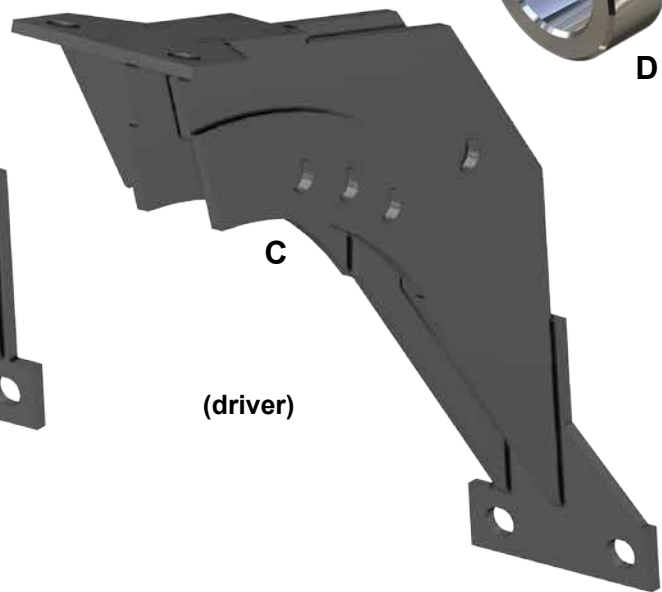
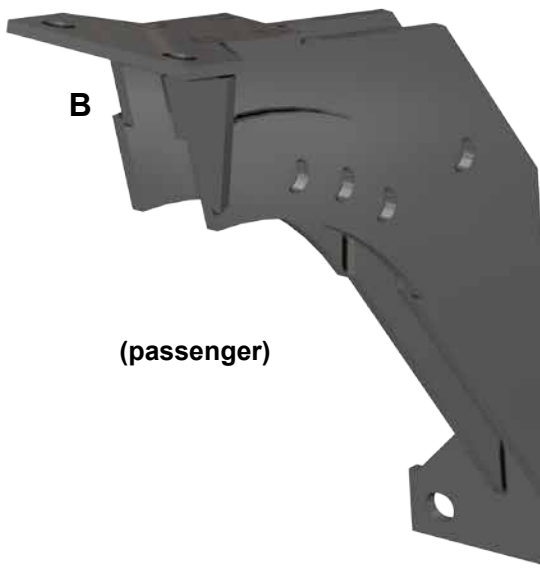
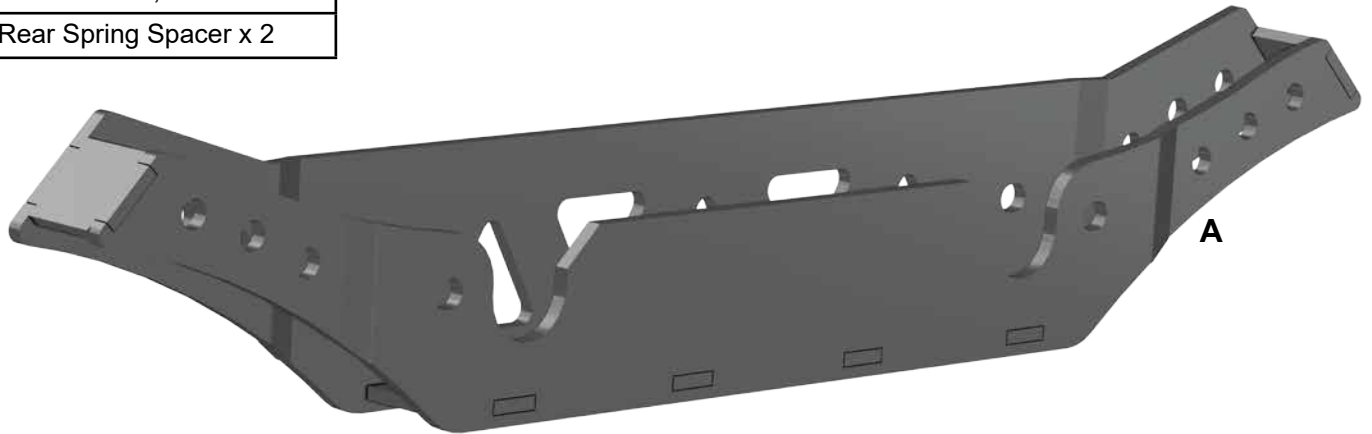

**Need help with your installation?**

 [sales@superatv.com](mailto:sales@superatv.com)
 [www.superatv.com](http://www.superatv.com)

 1-855-743-3427
  8:00am - 8:00pm EST M-Th  
 8:00am - 7:00pm EST Friday  
 9:00am - 2:00pm EST Saturday

Read instructions and view illustrations before beginning.

*Thank You*  
*For Choosing*  
**SUPERATV**.COM<sup>®</sup>

**Removal:** *Keep all components removed from machine.*

- Lift machine and secure on jack stands. Remove Wheels.
- Remove Front Shocks from Shock Mount.
- Unclip Wire Harness' from Shock Mount.
- Reroute Vent Hose away from Shock Mount.

*After Front Bracket (A) has been installed, reinstall above components in a suitable location.*

- Disconnect Rear Intakes and move out of way. Reconnect upon completion of installation.
- Remove Rear Shocks.

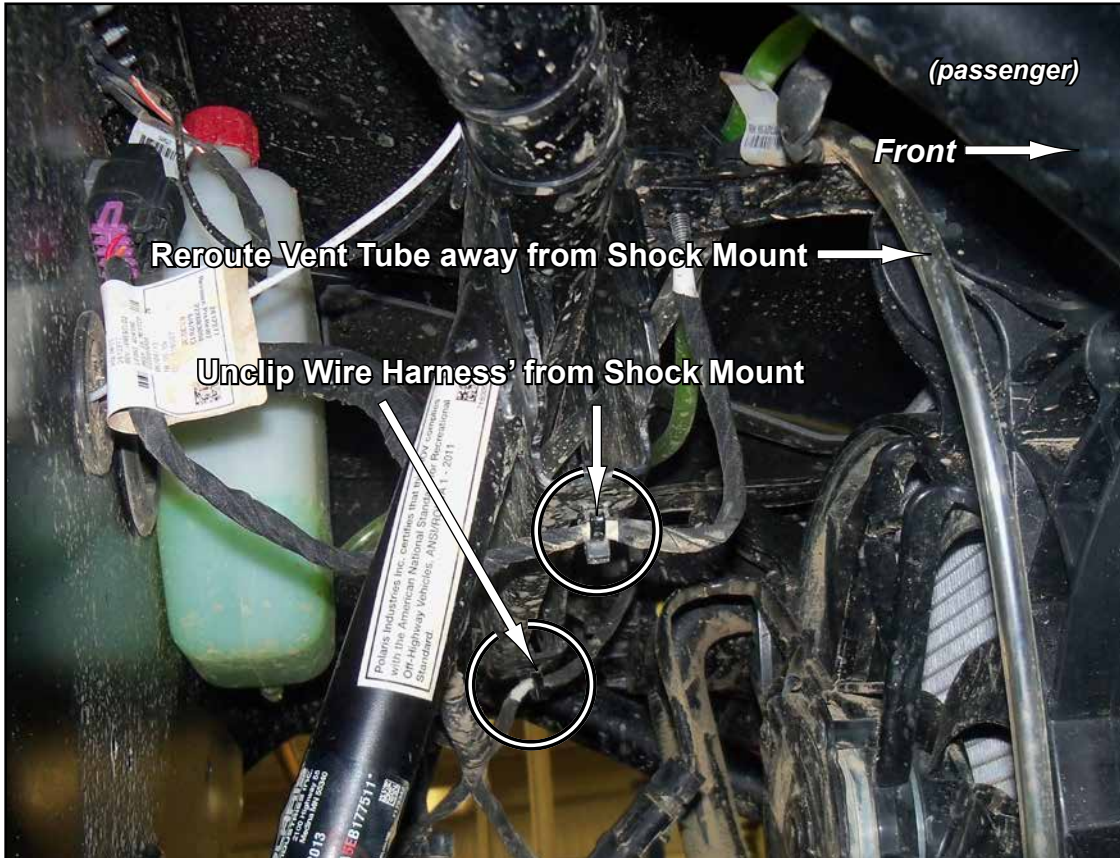

**Front Bracket:** *Do not tighten hardware completely unless noted.*

- Install Front Bracket (A) over stock Shock Mount.
- Insert Spacers and secure components with hardware shown.
- Determine amount of lift, and install Shocks to Front Bracket (A) with hardware shown.
- Tighten all hardware completely.

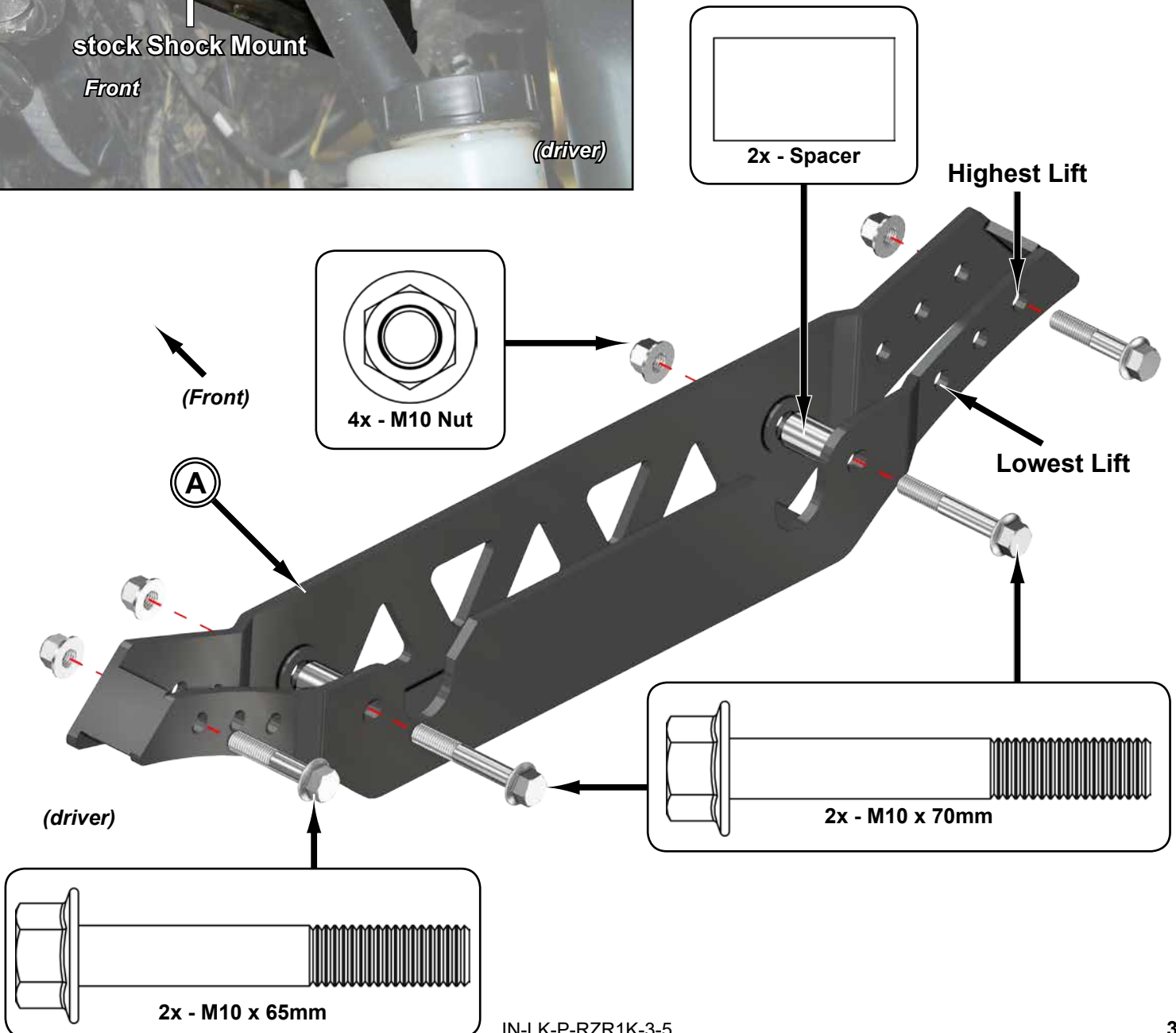
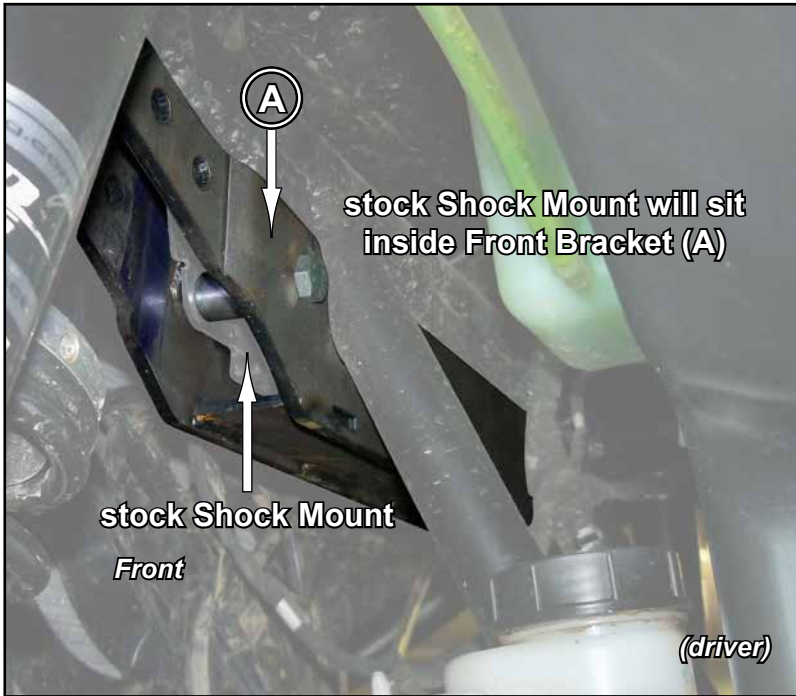

**Rear Brackets:** Do not tighten hardware completely unless noted.

- Install Rear Brackets (B-C) into stock Shock Mounts.
- Secure to stock Shock Mount with hardware shown.
- Install U-Bolts around Frame and secure to Rear Brackets (B-C) with Nylock Nuts.

**Go to Page 5 and install Rear Spring Spacers**

- Determine amount of lift, and install Shocks to Rear Brackets (B-C) with hardware shown. Install to A-Arms with stock hardware.
- Tighten all hardware completely.

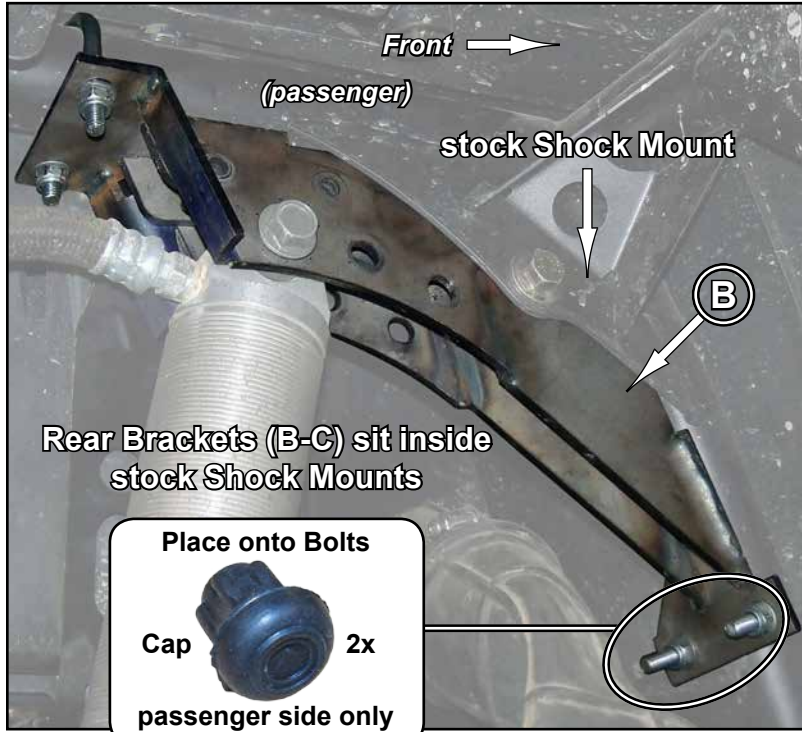

⚠ Due to manufacturer variations in Frame, slight drilling may be required. ⚠

Holes in Rear Brackets (B-C) and Shock Mounts to be in-line. Drill out holes, as needed, in Rear Brackets (B-C). Ø15mm max.

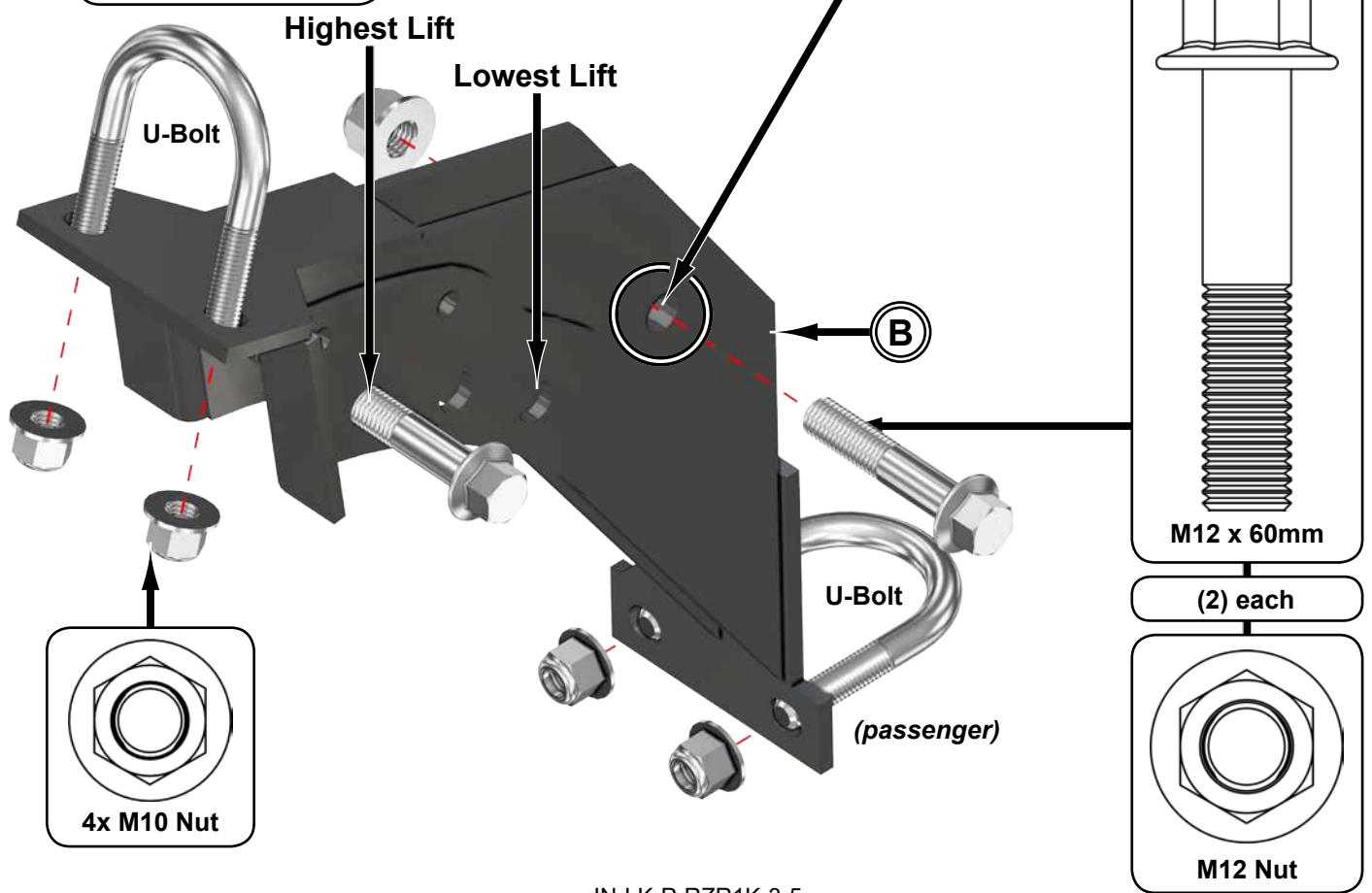

**Rear Spring Spacers (D);** SuperATV recommends using a lubricant on threads of Shock when adjusting Nut.

**Step 1:**

Use a Spanner Wrench to adjust Nut.

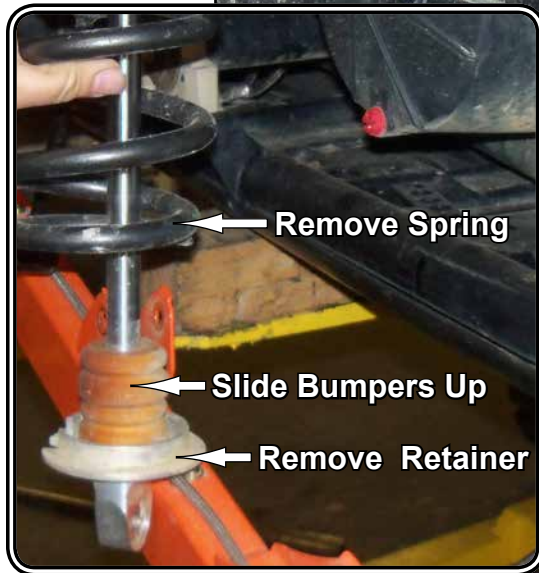
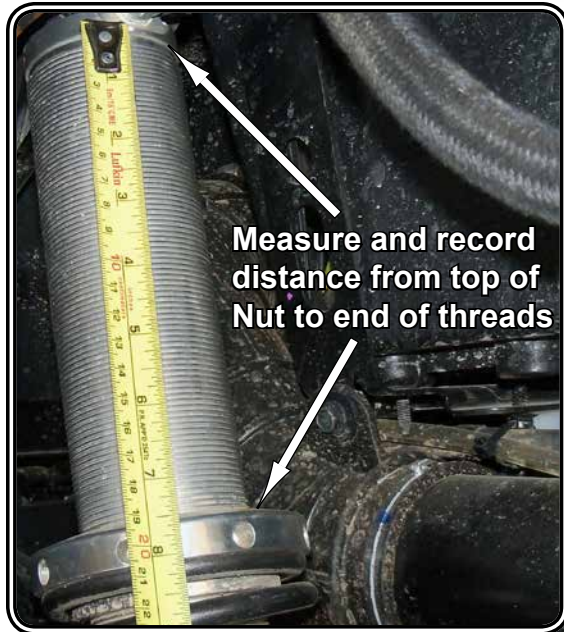

**Step 2:**

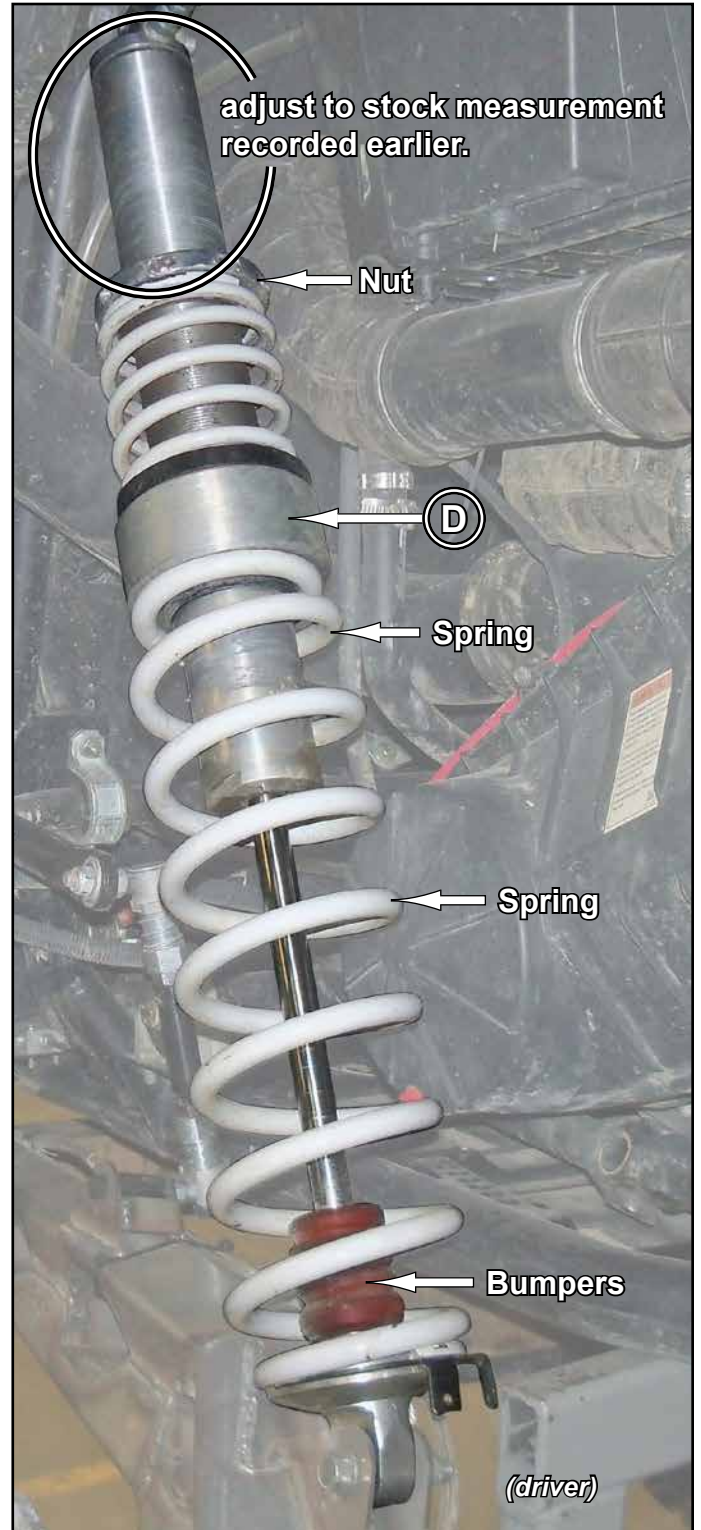

**Liability Statement**

SuperATV's® products are designed to best fit user's ATV/UTV under stock conditions. Adding, modifying, or fabricating any factory or aftermarket parts will void any warranty provided by SuperATV® and is not recommended. SuperATV's® products could interfere with other aftermarket accessories. If user has aftermarket products on machine, contact SuperATV® to verify that they will work together.

Although SuperATV® has thousands of satisfied customers, user should be aware that installing lift kits, long travel, or suspension kits, tires, etc. will change the ride of machine and may increase maintenance and part wear. Operating any off-road machine while, or after, consuming alcohol and/or drugs increases risk of bodily harm or death. No warranty or representation is made as to this product's ability to protect user from severe injury or death. SuperATV® urges operators and occupants to wear a helmet and appropriate riding gear at all times.

By purchasing and installing SuperATV® products, user agrees that should damages occur, SuperATV® will not be held responsible for loss of time, use, labor fees, replacement parts, or freight charges. SuperATV®, nor any 3rd party, will not be held responsible for any direct, indirect, incidental, special, or consequential damages that result from any product purchased from SuperATV®. The total liability of seller to user for all damages, losses, and causes of action, if any, shall not exceed the total purchase price paid for the product that gave rise to the claim.

SuperATV® will warranty only parts provided by SuperATV®. Any damage or problems with OEM housings, bearings, seals, or other manufacturers' products will not be covered by SuperATV®. SuperATV® parts and products are not warrantied if item was not installed properly, misused, or modified.

Installing, adding, modifying, or fabricating any factory or aftermarket product to your ATV/UTV may violate certain local, state, and federal laws. Be advised that laws vary depending on town, city, county, state, etc. Use of certain products on public streets, roads, or highways may be in violation law. The Buyer is solely and exclusively legally and personally responsible for any violation of the law by the installation or use of the product. You must abide by all local, state, and federal laws, including but not limited to vehicle safety, traffic laws, and ordinances. It is your responsibility to know the laws and how they apply to you.

The Buyer is responsible to fully understand the capability and limitations of his/her vehicle according to manufacturer specifications, warnings and instructions and agrees to hold SuperATV® harmless from any damage resulting from failure to adhere to such specifications, warnings and/ or instructions. The Buyer is also responsible to obey all applicable federal, state, and local laws and ordinances when operating his/her vehicle while using this product, and the Buyer agrees to hold SuperATV® harmless from any violation thereof.