

INSTALLATION INSTRUCTIONS
7" - 10" Adjustable Lift Kit:
for Polaris RZR[®] XP 1000

A Press or Ball Joint tool is required to remove and install Ball Joints.

Item	Description
A	Upper A-Arm, Passenger
B	Upper A-Arm, Driver
C	Lower A-Arm, Passenger
D	Lower A-Arm, Driver
H	Rear Spring Spacer x 2

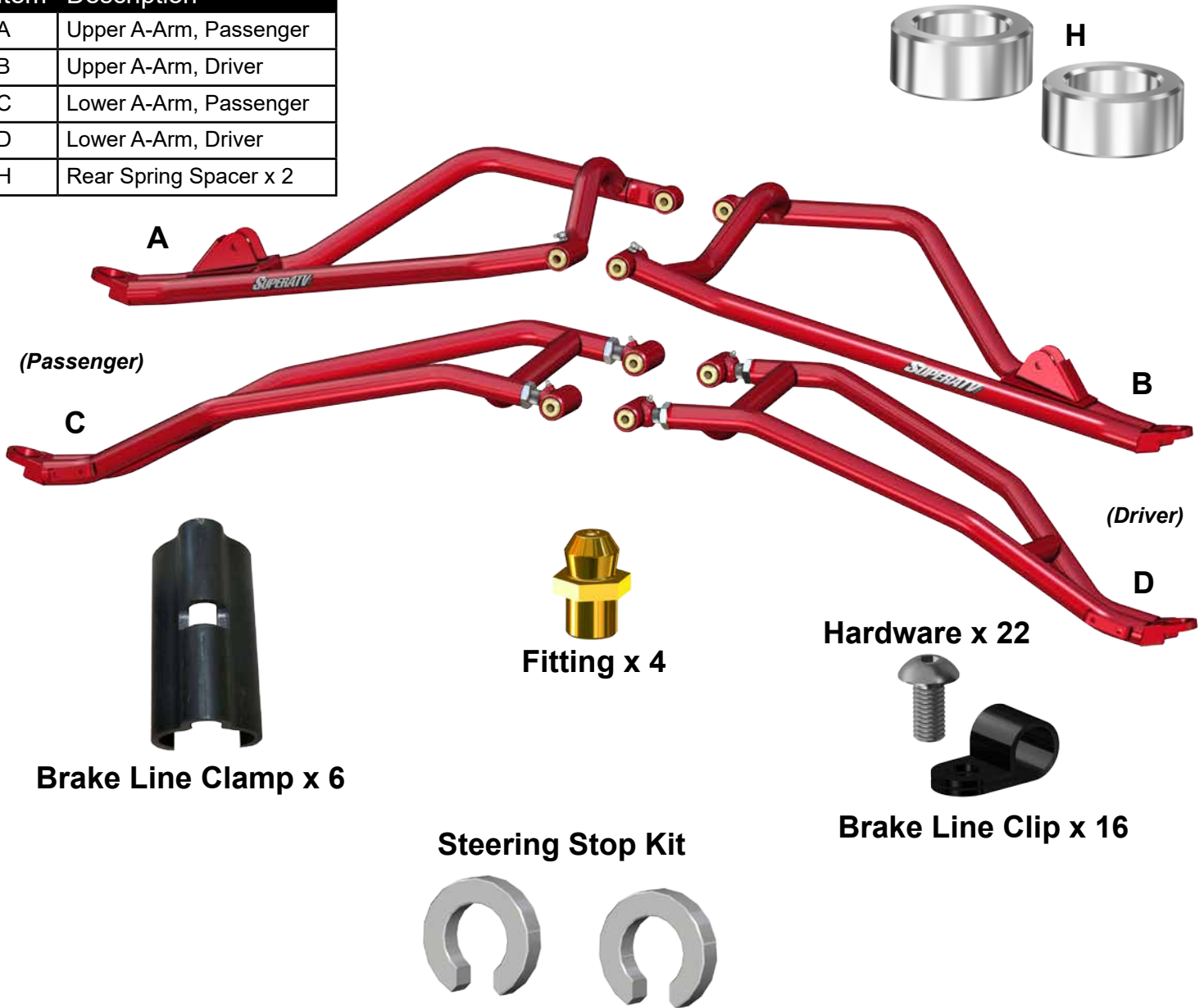

(Kit contents continue on following pages)

Need help with your installation?

✉ sales@superatv.com 🖥 www.superatv.com

☎ 1-855-743-3427 🕒 8:00am - 8:00pm EST M-Th
 8:00am - 7:00pm EST Friday
 9:00am - 2:00pm EST Saturday

Read instructions and view illustrations before beginning.

Thank You
For Choosing
SUPERATV.COM[®]

(Kit contents continued)

Item	Description
J	Front Lift Bracket



Brake Lines (M)

Location	Length (Approx)
Right Rear	90"
Right Front	50"
Left Rear	58"
Left Front	42"

Front Brake Lines have same style fittings at each end.



Item	Description
R	Trailing Arm, Passenger
S	Hub Mount, Passenger
T	Trailing Arm, Driver
U	Hub Mount, Driver

(Kit contents continued)

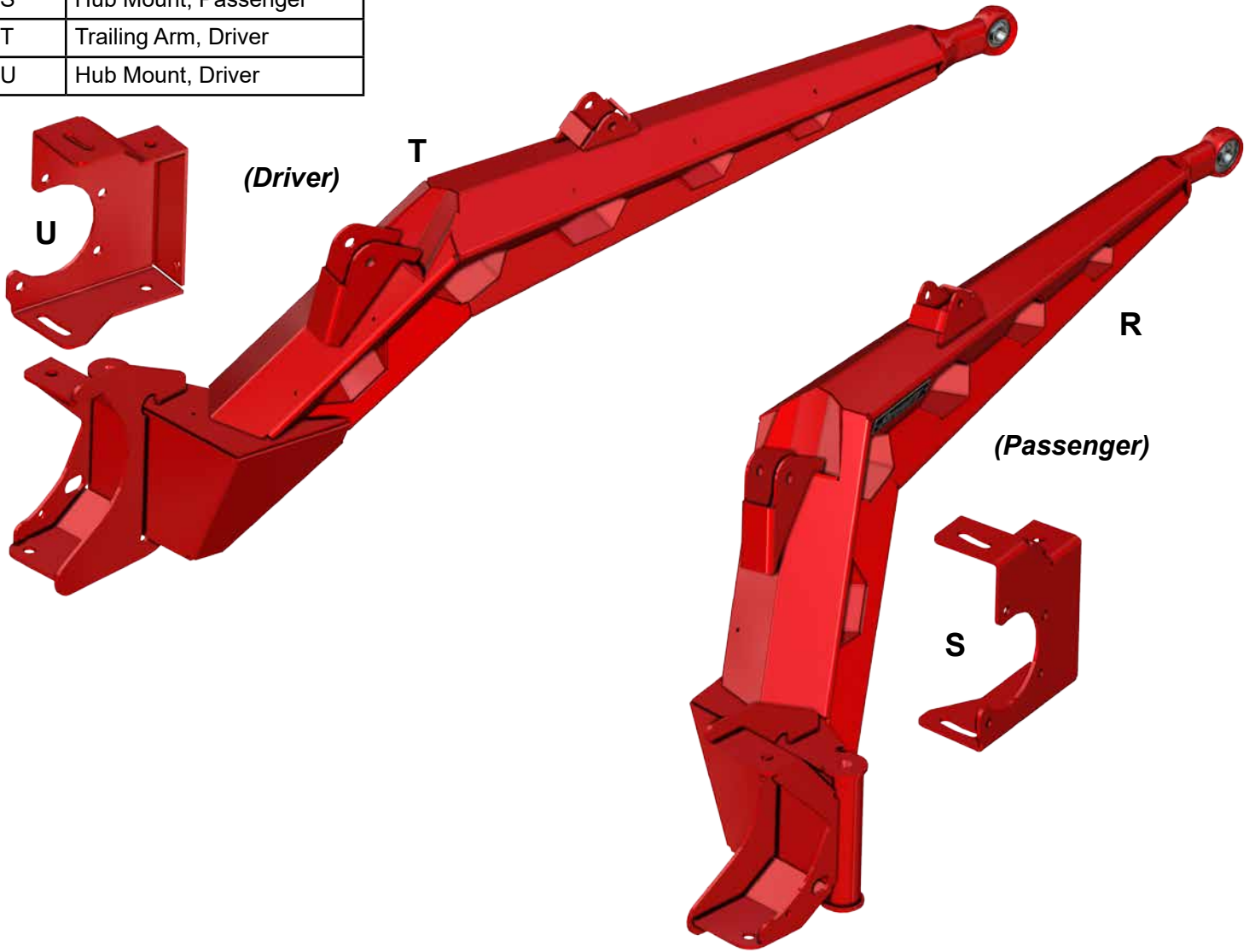

Front components shown must be removed; *Keep all components removed from machine.*

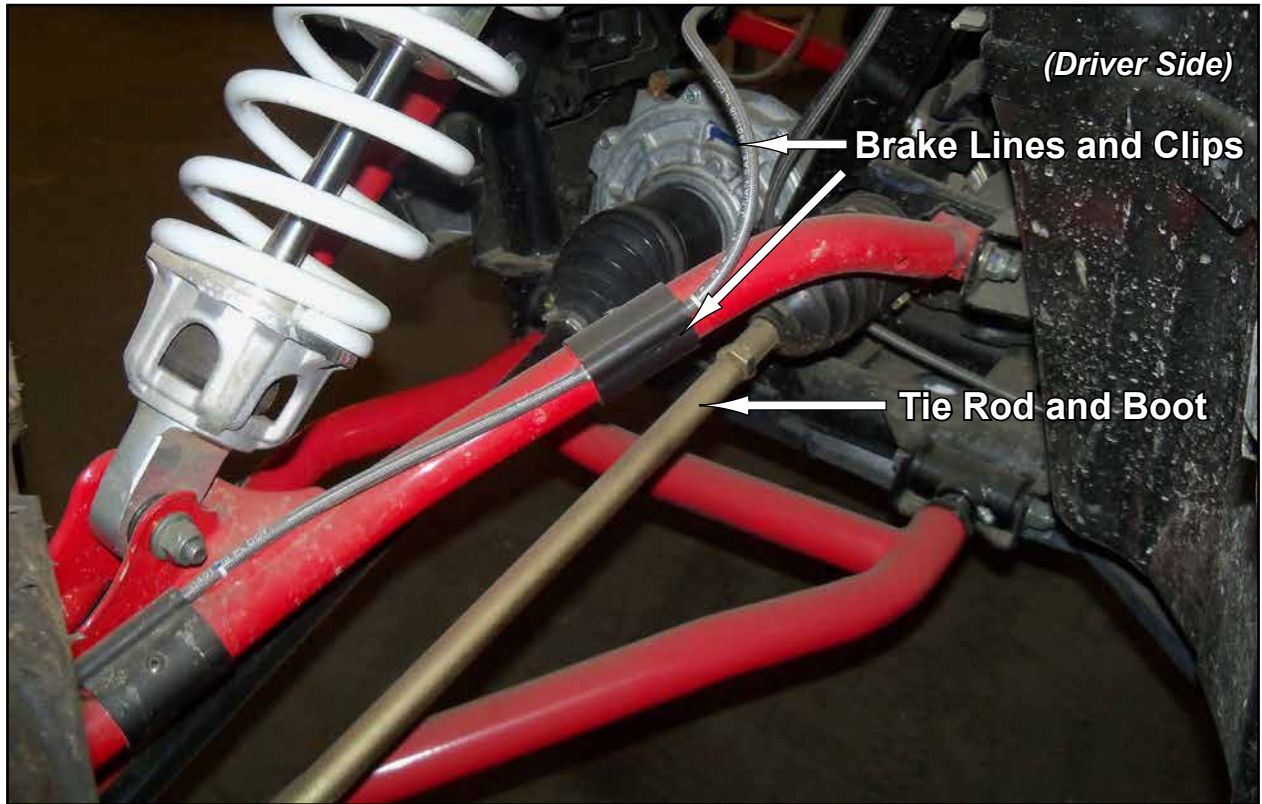
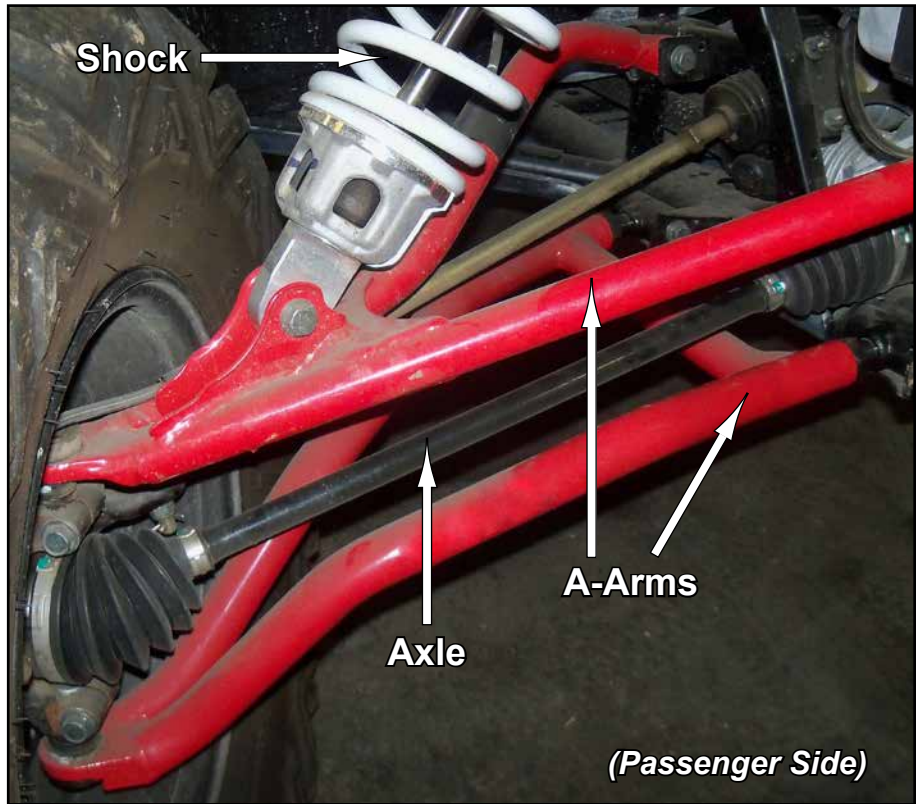
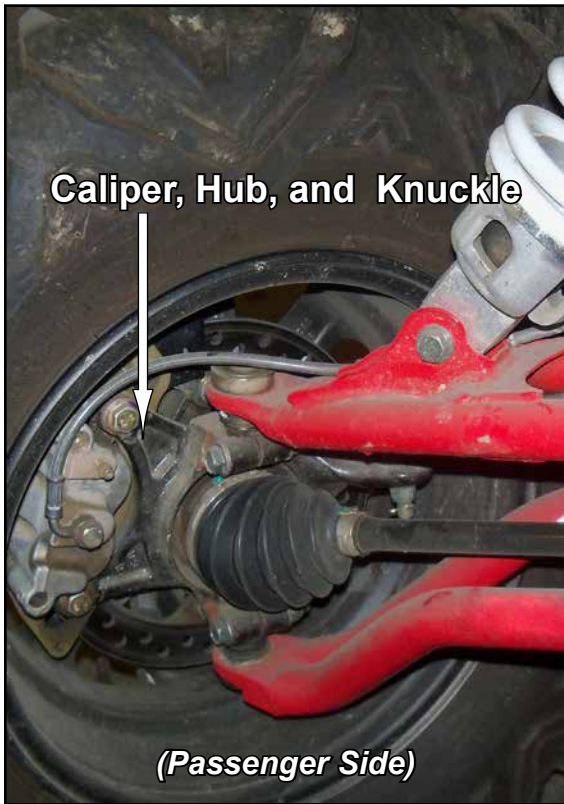

Vent Tube Rerouting:

- Unclip Wire Harness' from Shock Mount.
- Reroute Vent Tube away from Shock Mount.
- **After** Front Bracket (J) has been installed, reinstall above components in a suitable location.



Steering Stop Installation: *Rack and Pinion shown off machine for clarity*

- Install Steering Stop onto Rack and Pinion shaft; repeat for opposite side.
- Do not reinstall stock Boots.

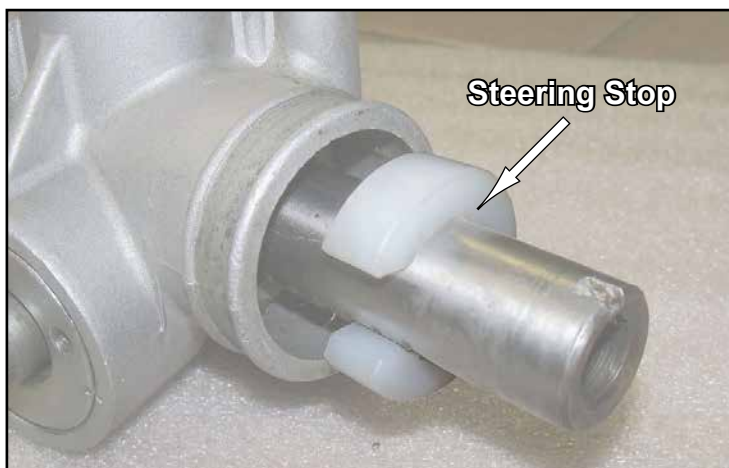

—— see Z-Bend Tie Rod instructions and install ——



install stock Ball Joints

PIVOT BLOCK SETTINGS

- Place new A-Arms onto a flat surface and verify dimension shown.
- *Negative 1° camber setting is achieved when Pivot Blocks are set to this dimension.*
- See last page for additional camber information.

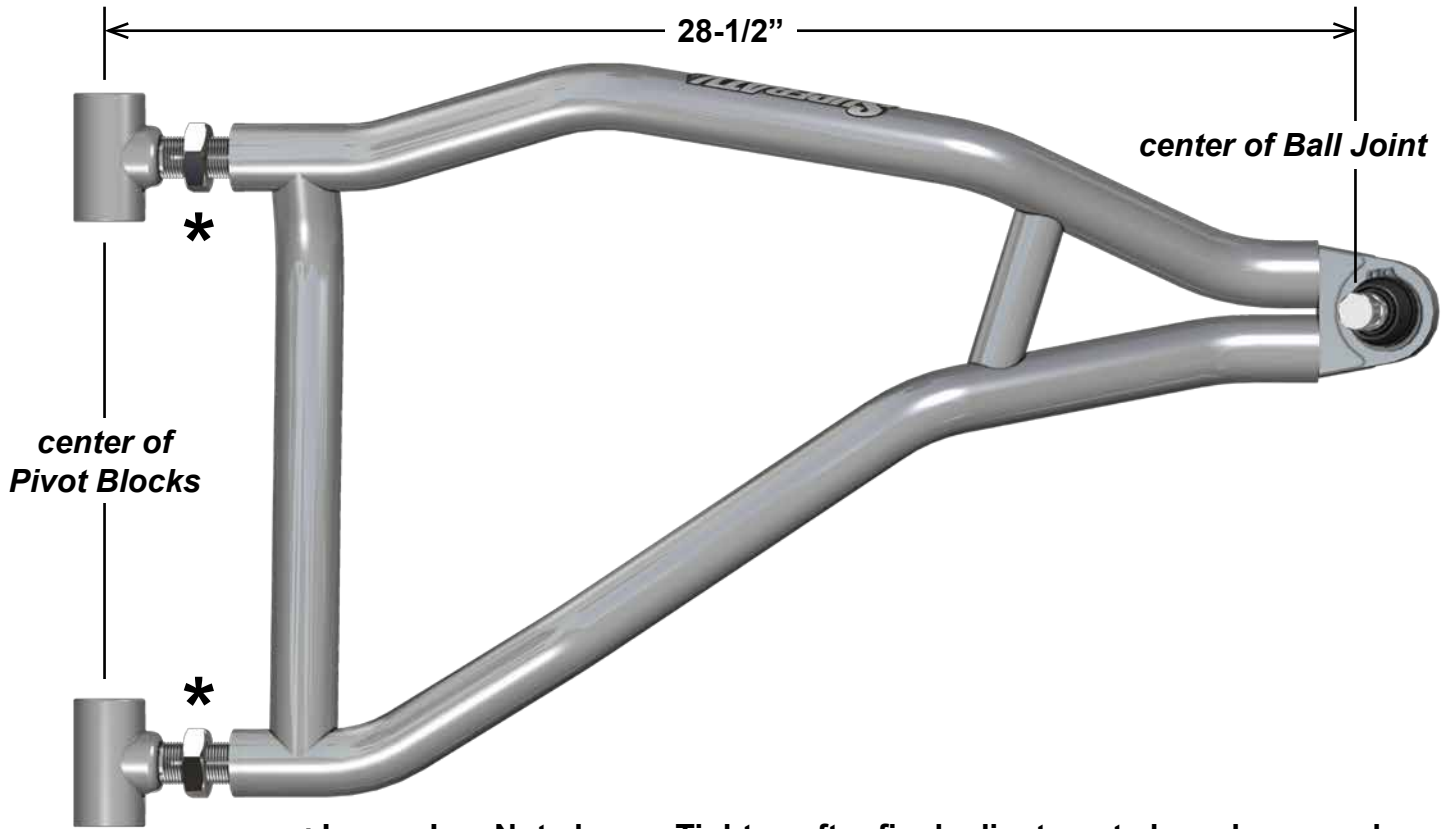

*** Leave Jam Nuts loose. Tighten after final adjustments have been made.**

Front Bracket installation: *Do not tighten hardware completely unless noted.*

- Install Front Lift Bracket (J) to Frame with hardware shown.
- Determine lift setting and use hardware shown when reinstalling Shocks.

(Passenger Side)

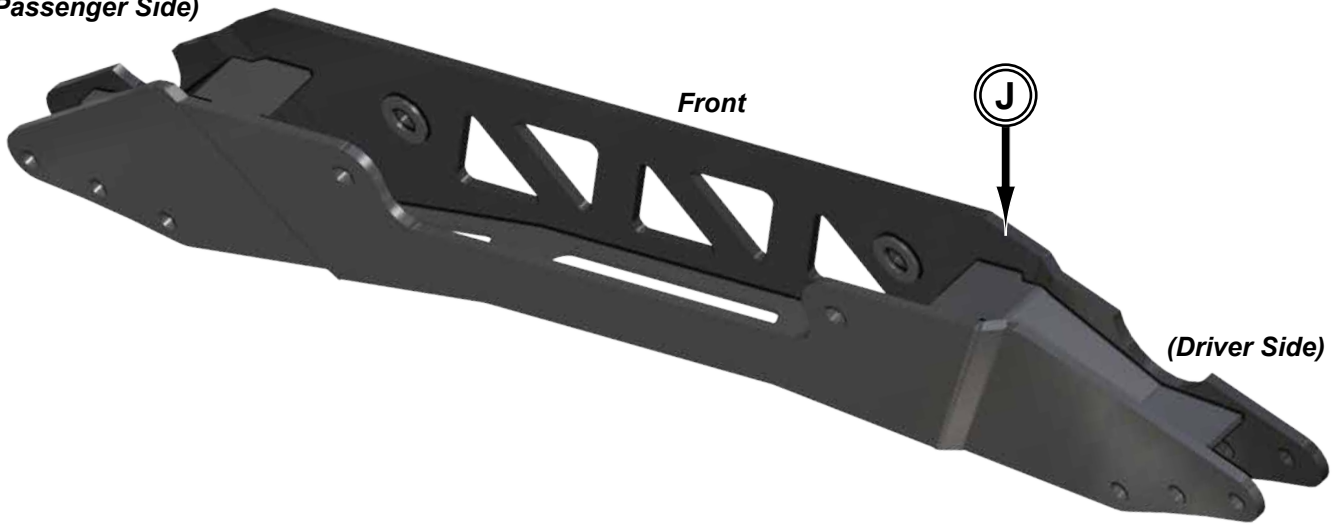

Hint: use needle nose pliers or a telescoping magnet to place Spacers into position.

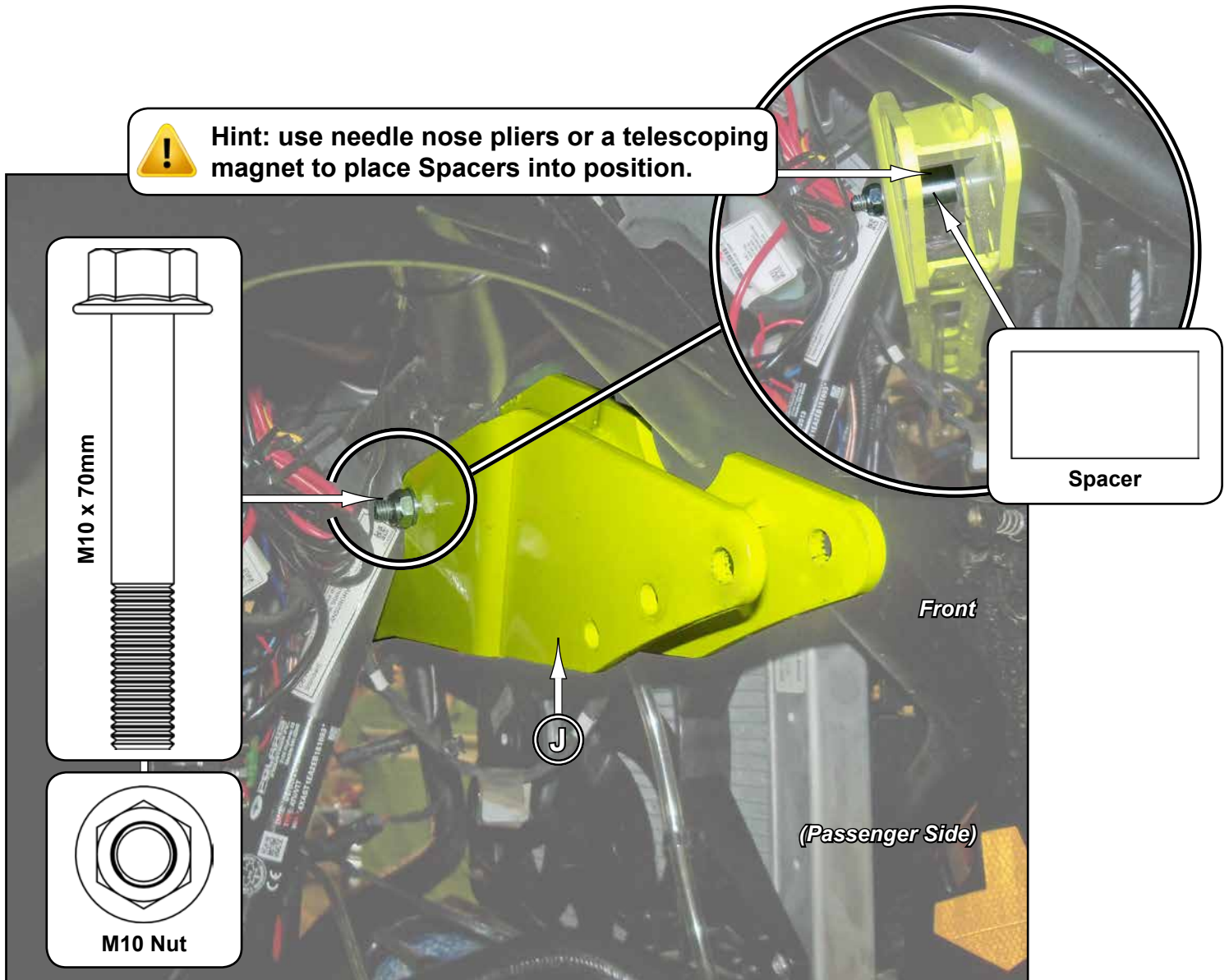

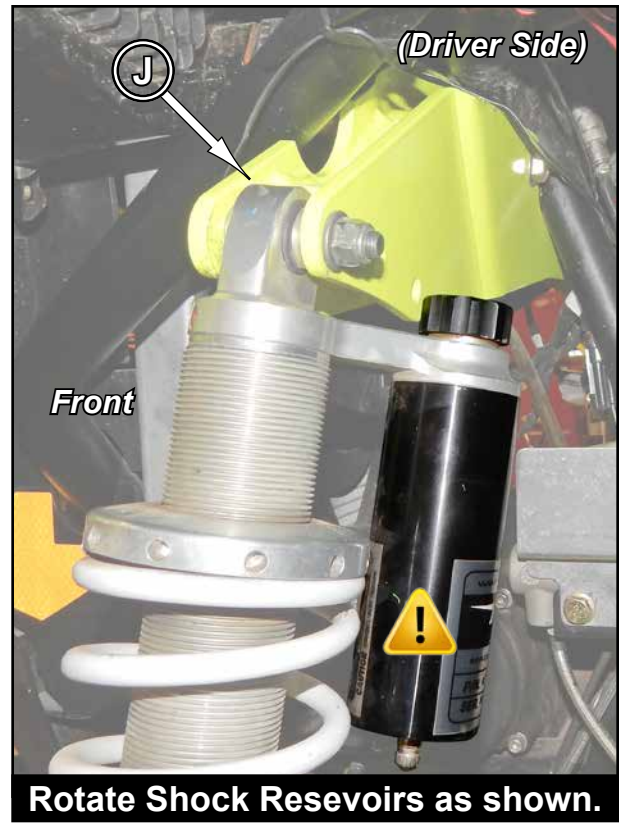
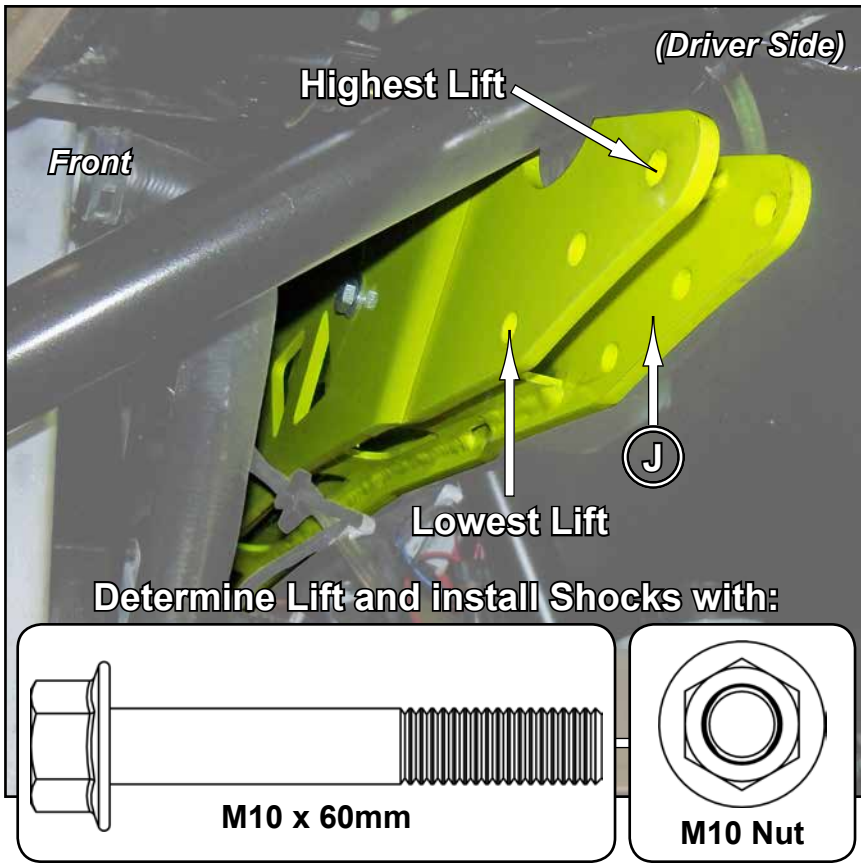

Front installation: *Do not tighten hardware completely unless noted.*

- Install A-Arms (A-D) to Frame with stock hardware. **Do not install any Nuts to Lower Arms until all final adjustments have been completed.**
- Install new Axles.



Front Installation continued:

- Install Shocks to A-Arms (A)(B) with stock hardware.
- Secure to Front Lift Brackets (J) with hardware shown.
- Install and secure Front Brake Lines (M) to A-Arms (A)(B) with Brake Line Clips, Brake Line Clamps, and hardware shown. Ensure no binding or interference can occur when in use.

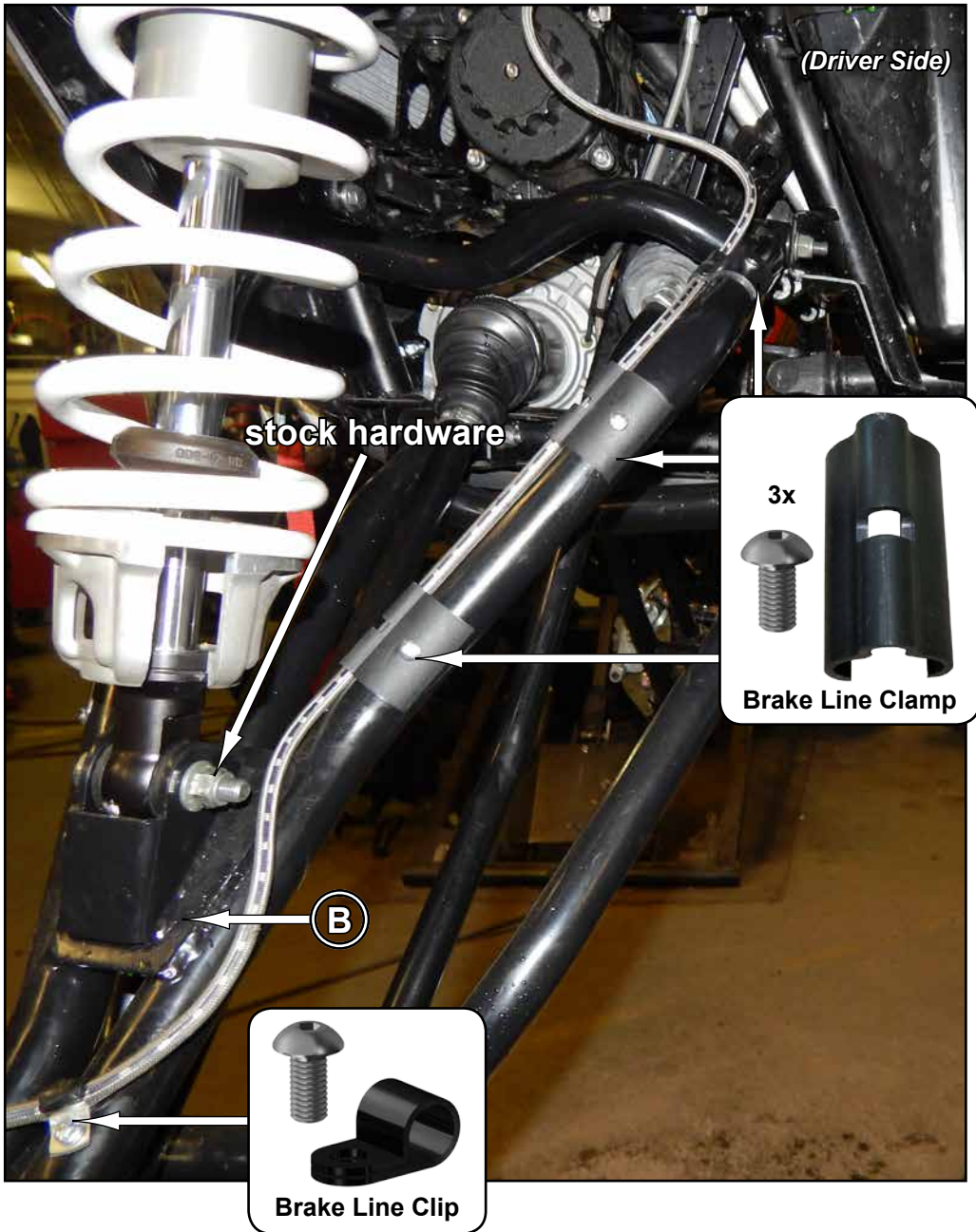

Rear components shown must be removed from both sides;
Keep all components removed from machine.

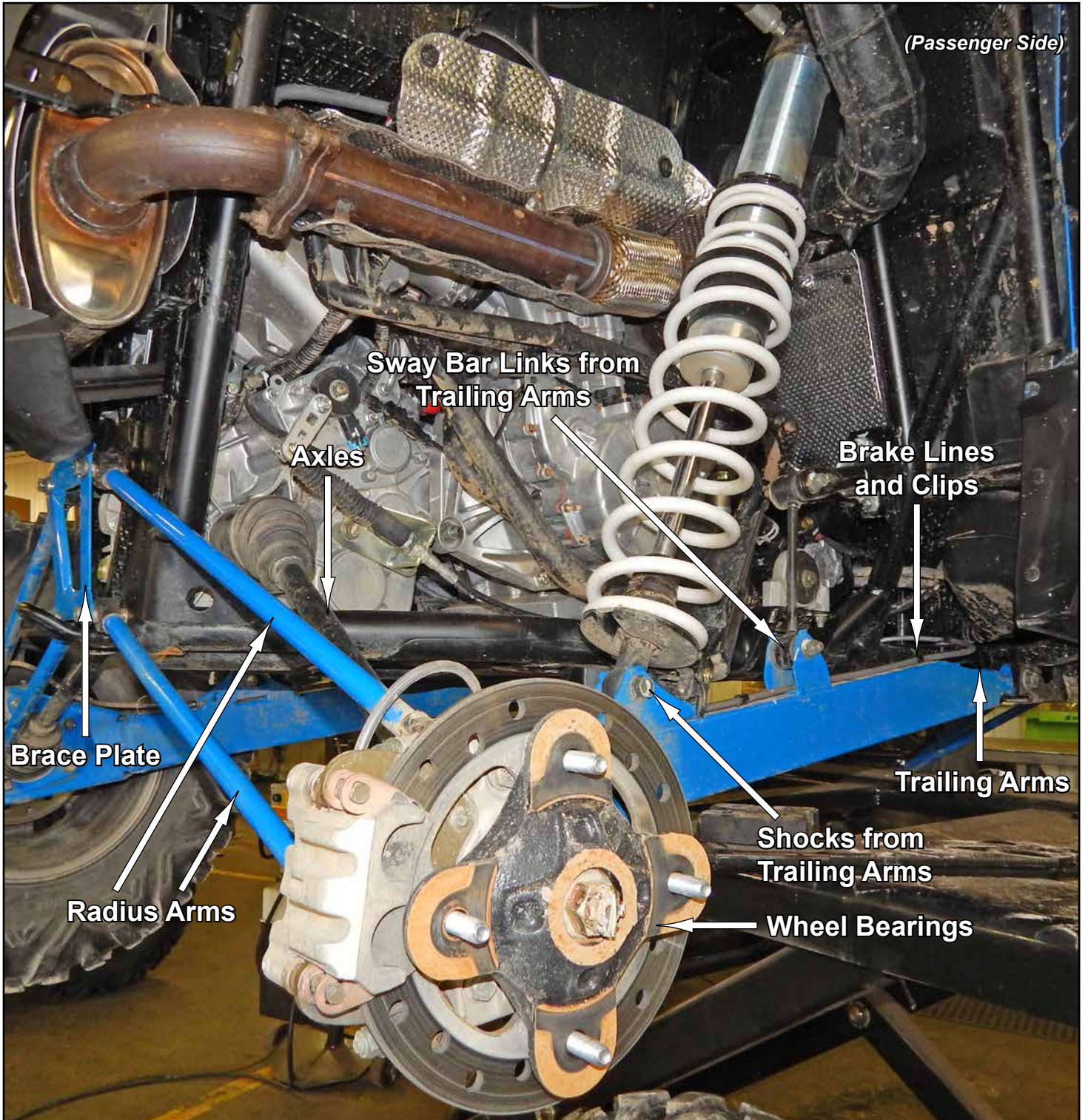

Rear Installation: *Do not tighten hardware completely unless noted.*

- Install Trailing Arms (R)(T) to Frame with stock hardware and provided Trailing Arm Bushings.
- Install Sway Bar Link to Trailing Arm (R)(T) with stock hardware.
- Install new Axles.
- Adjust Preload Rings on Shocks, **page 13**. Secure to Trailing Arms with stock hardware.
- Install Radius Arms and Brace Plate, **see included Radius Arms instructions**. Secure Radius Arms to Wheel Bearings with stock hardware during "Hub Mount Installation", **pages 14 - 15**.

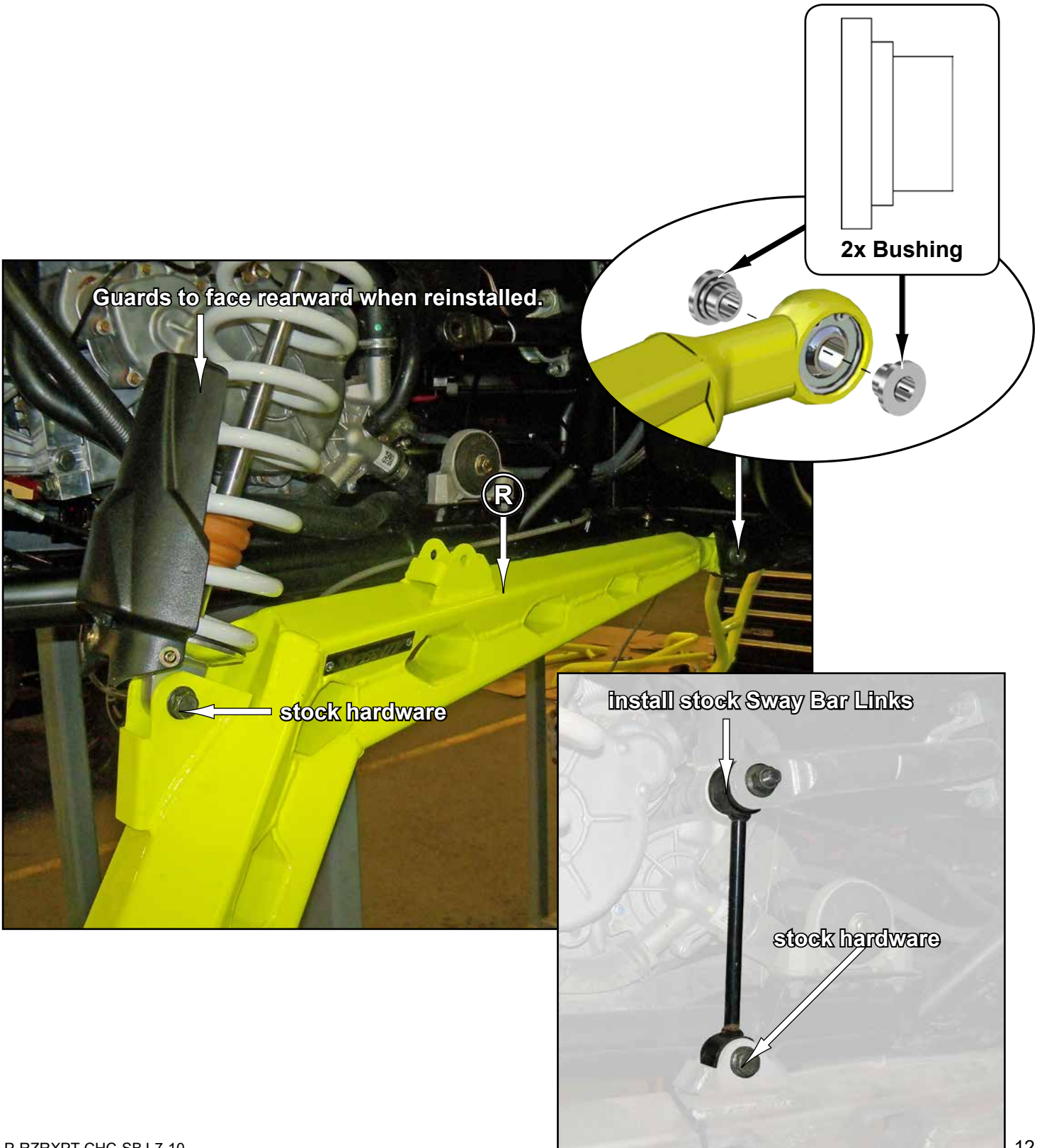

Rear Spring Spacers (H); SuperATV recommends using a lubricant on threads of Shock when adjusting Nut.

Step 1:

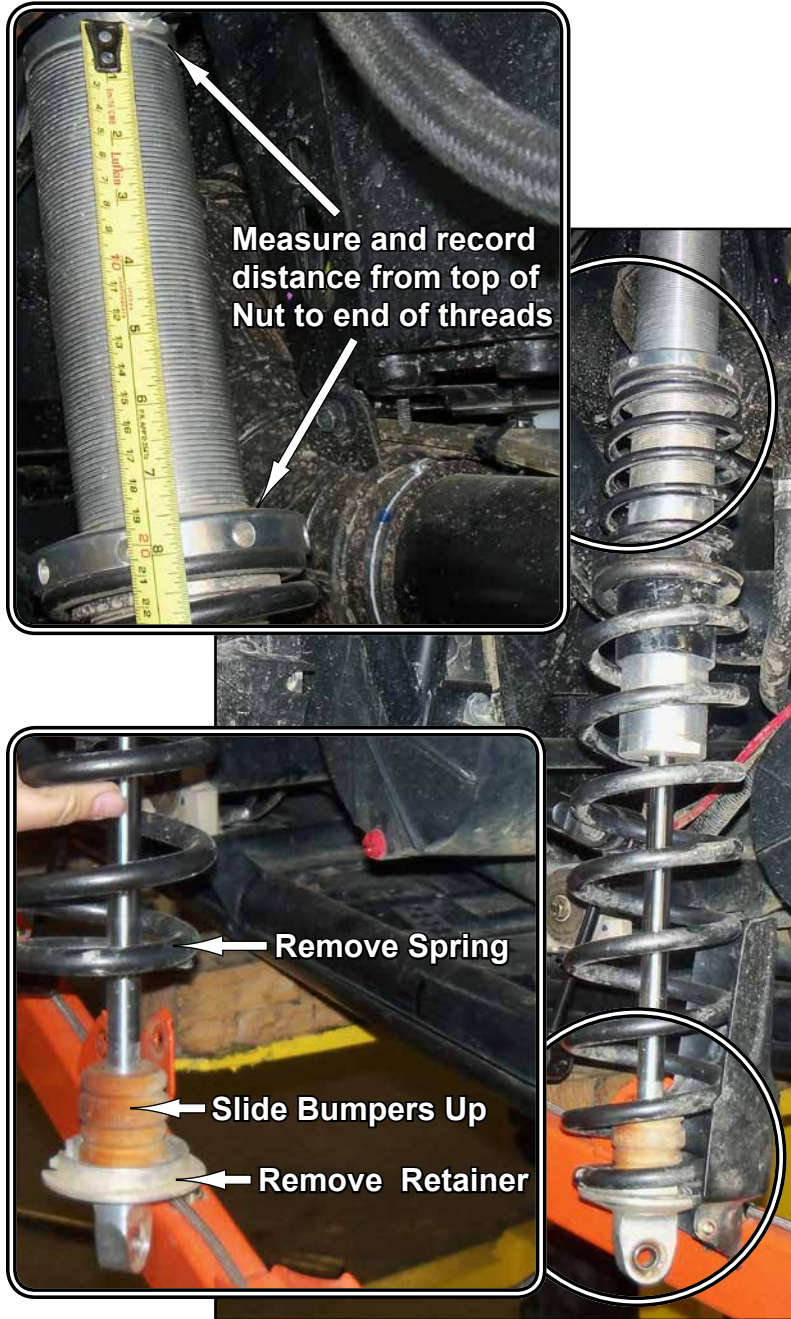

Step 2:

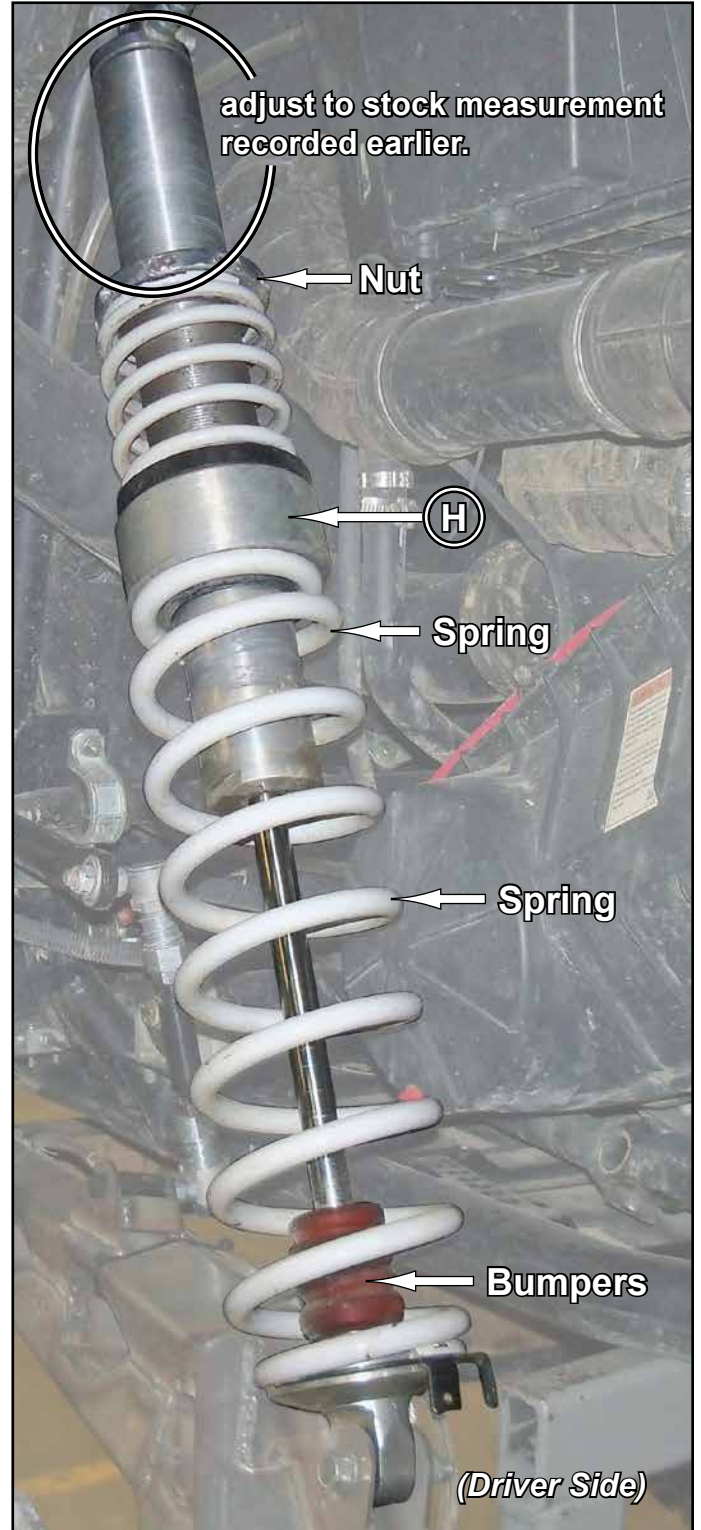

Hub Mount installation and adjustments: *Do not tighten hardware completely unless noted.*

1. Install Hub Mount (U) to Trailing Arm (T) with M12 hardware shown. **Do not tighten hardware.**
2. Install Long Set Screw and Nut into Trailing Arm (T). **Leave Set Screw flush with Nut or just past flush.**
 - Rotate Hub Mount (U) until contact with Set Screw is made.
repeat steps for opposite side
3. Use stock hardware and Install Wheel Bearings, Calipers, and Tires; set machine on ground.
4. Set Toe by turning previously installed Long Set Screw.
 - Once Toe is set, tighten previously installed M12 hardware.

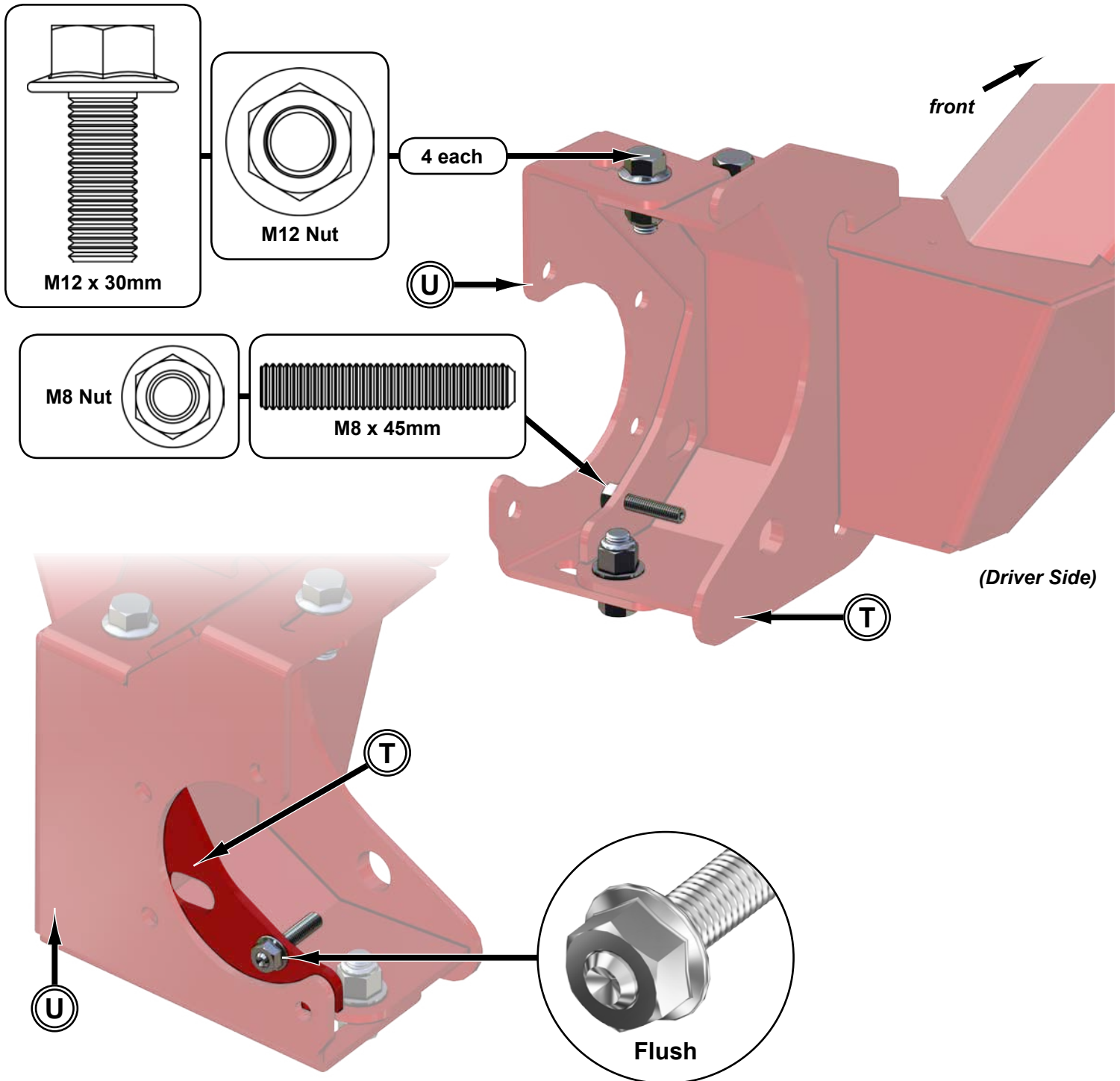

(Hub Mount installation and adjustment illustrations continue on following page)

Hub Mount installation and adjustments continued:

5. Raise machine and remove tires.
6. Install Short Set Screw and Nut into Trailing Arms; tighten completely to lock in Toe adjustments.

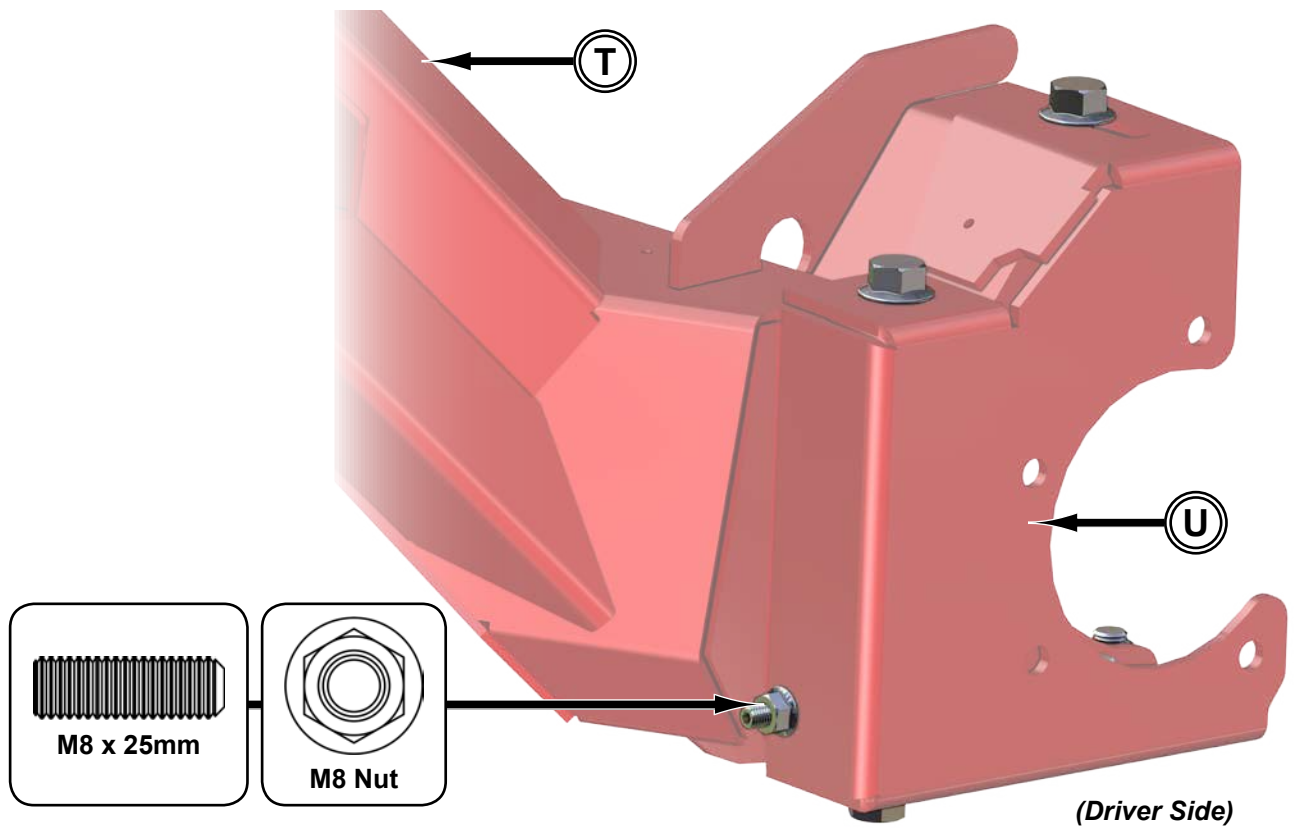

Tighten all hardware completely.

Rear Brake Line (M) Installation:

- Install Rear Brake Lines (M); *Right is 90" long and Left is 58" long approximately*. Secure to Trailing Arms with Brake Line Clips and hardware shown. Ensure no binding or interference can occur when in use.

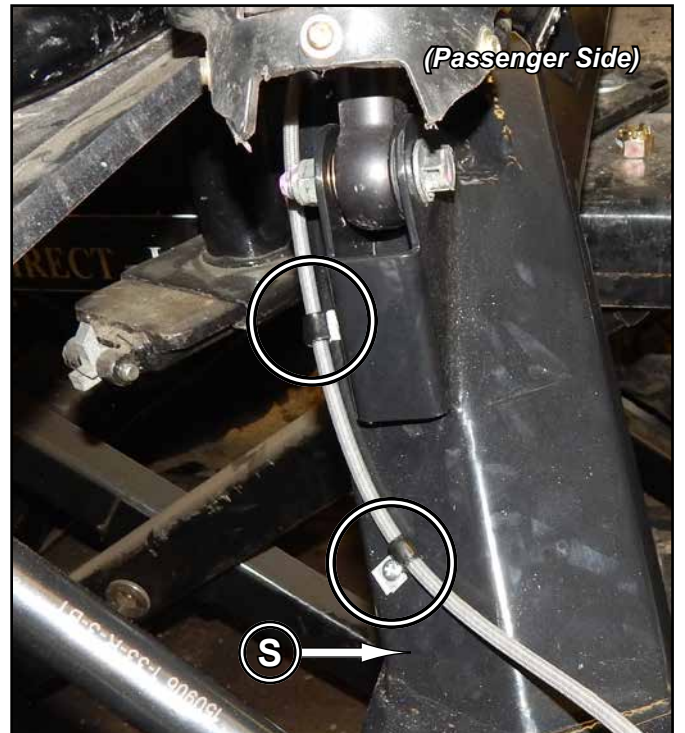
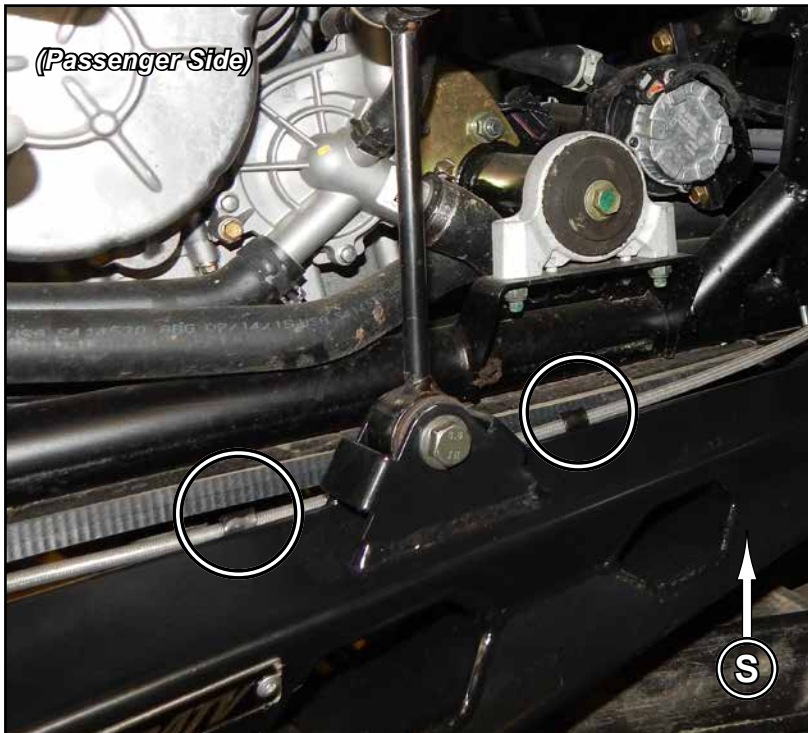
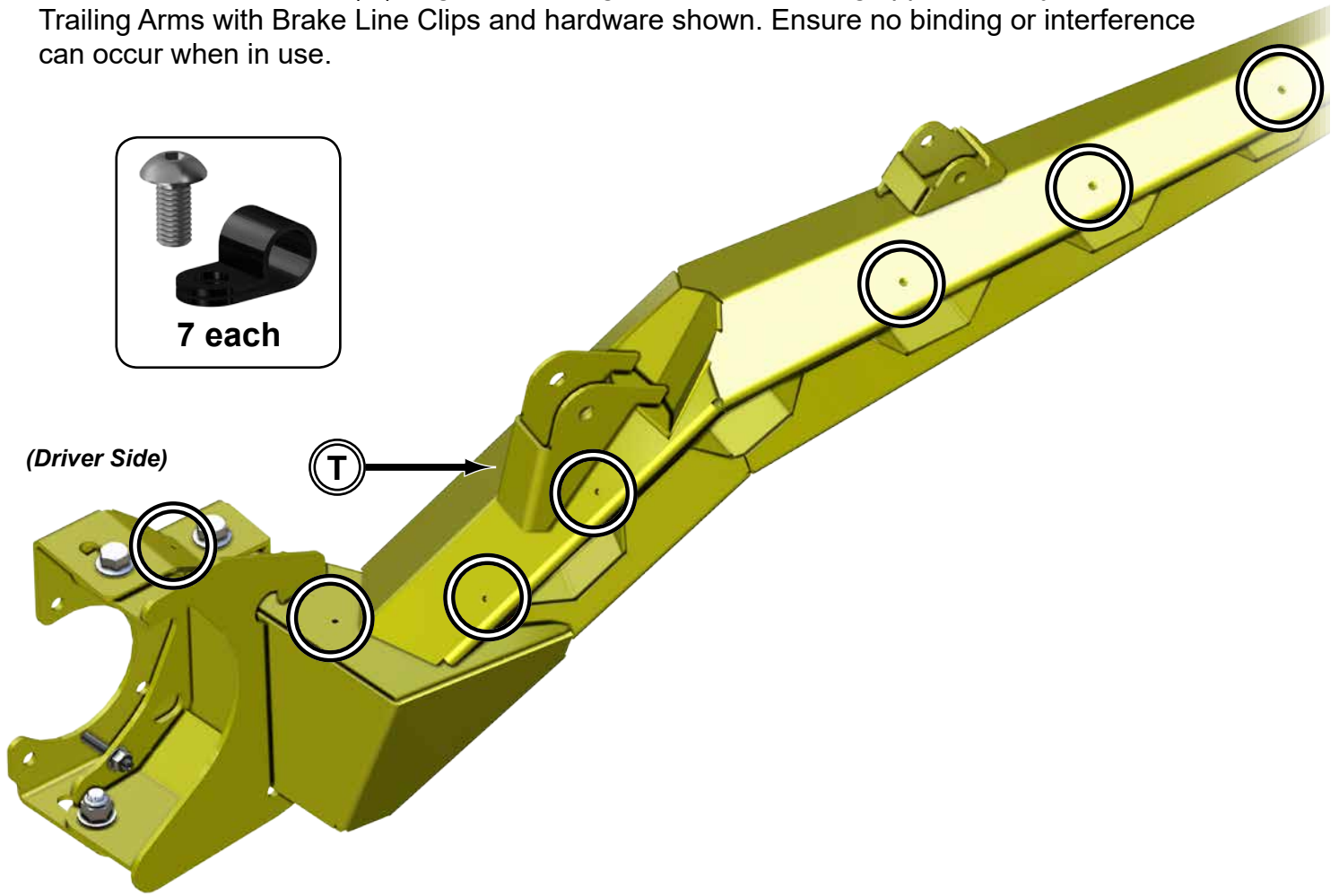

Small Boot



Large Boot

(2) different sized Ball and Socket sets included.
 Compare Stock size and install appropriate set.

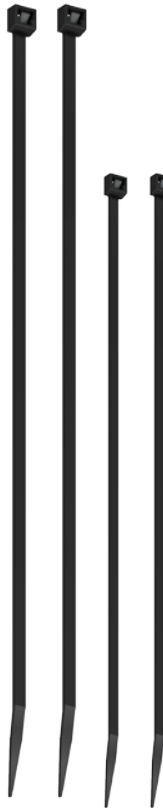

Wire Ties



(use with tapered Spindle Hole)



2 x Tie Rod Shaft



(use with Straight Spindle Hole)

Need help with your installation?



sales@superatv.com



www.superatv.com



1-855-743-3427



8:00am - 8:00pm EST M-Th
 8:00am - 7:00pm EST Friday
 9:00am - 2:00pm EST Saturday

Read instructions and view illustrations before beginning.

Thank You

For Choosing



- Remove Jam Nuts from Ball and Sockets.
- Install Ball and Sockets to Rack and Pinion. Use Loctite.
- Install Boots to Rack and Pinion and secure with Wire Ties.
- Reinstall Jam Nuts to Ball and Sockets.
- Install Tie Rod Shafts to Ball and Sockets.
- Secure Tie Rod Ends to Spindles with appropriate hardware.

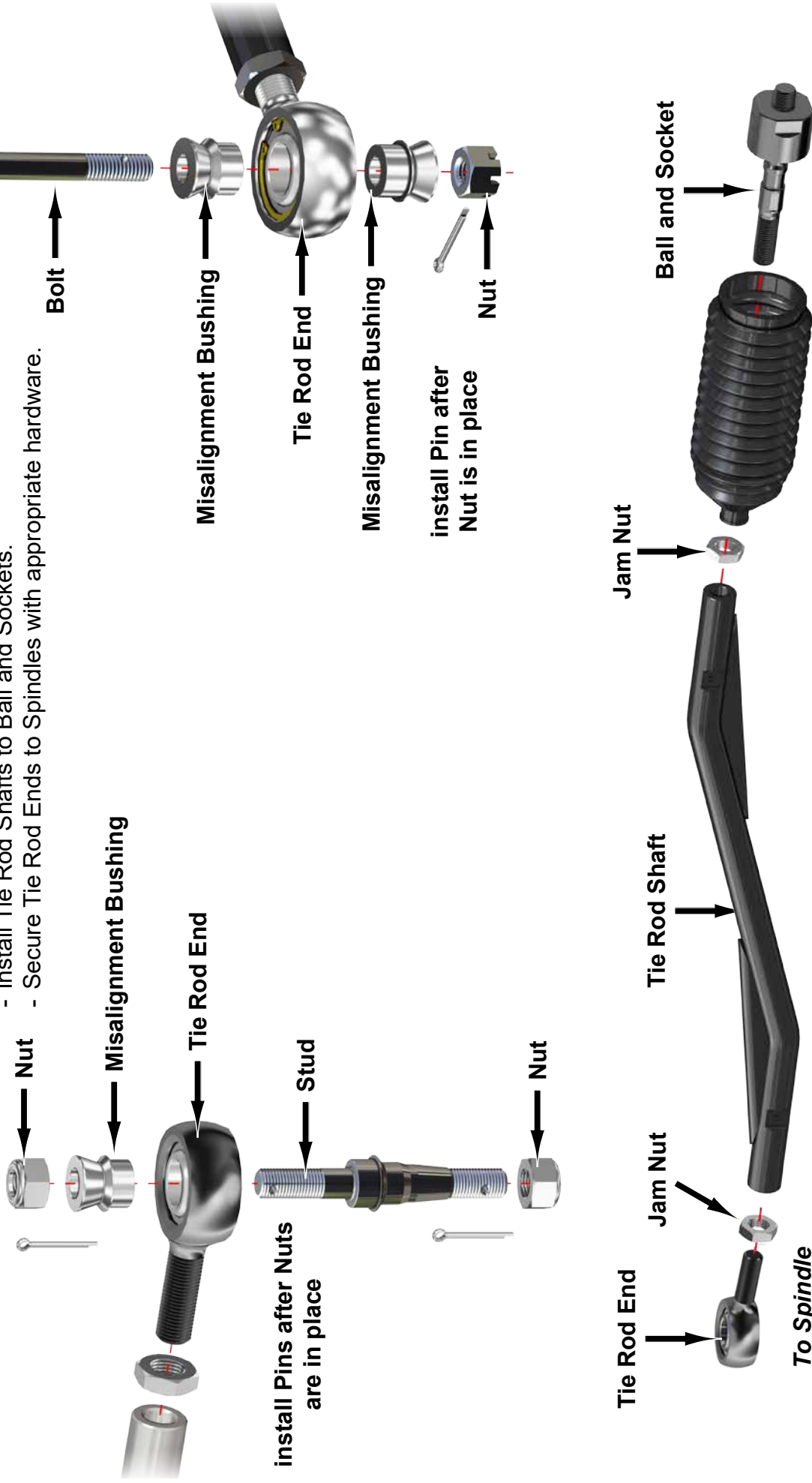

- Before initial ride, set toe-in of vehicle.
- After initial ride check to see that hardware remained tight.

Liability Statement

SuperATV's® products are designed to best fit user's ATV/UTV under stock conditions. Adding, modifying, or fabricating any factory or aftermarket parts will void any warranty provided by SuperATV® and is not recommended. SuperATV's® products could interfere with other aftermarket accessories. If user has aftermarket products on machine, contact SuperATV® to verify that they will work together.

Although SuperATV® has thousands of satisfied customers, user should be aware that installing lift kits, long travel, or suspension kits, tires, etc. will change the ride of machine and may increase maintenance and part wear. Operating any off-road machine while, or after, consuming alcohol and/or drugs increases risk of bodily harm or death. No warranty or representation is made as to this product's ability to protect user from severe injury or death. SuperATV® urges operators and occupants to wear a helmet and appropriate riding gear at all times.

By purchasing and installing SuperATV® products, user agrees that should damages occur, SuperATV® will not be held responsible for loss of time, use, labor fees, replacement parts, or freight charges. SuperATV®, nor any 3rd party, will not be held responsible for any direct, indirect, incidental, special, or consequential damages that result from any product purchased from SuperATV®. The total liability of seller to user for all damages, losses, and causes of action, if any, shall not exceed the total purchase price paid for the product that gave rise to the claim.

SuperATV® will warranty only parts provided by SuperATV®. Any damage or problems with OEM housings, bearings, seals, or other manufacturers' products will not be covered by SuperATV®. SuperATV® parts and products are not warrantied if item was not installed properly, misused, or modified.

Installing, adding, modifying, or fabricating any factory or aftermarket product to your ATV/UTV may violate certain local, state, and federal laws. Be advised that laws vary depending on town, city, county, state, etc. Use of certain products on public streets, roads, or highways may be in violation law. The Buyer is solely and exclusively legally and personally responsible for any violation of the law by the installation or use of the product. You must abide by all local, state, and federal laws, including but not limited to vehicle safety, traffic laws, and ordinances. It is your responsibility to know the laws and how they apply to you.

The Buyer is responsible to fully understand the capability and limitations of his/her vehicle according to manufacturer specifications, warnings and instructions and agrees to hold SuperATV® harmless from any damage resulting from failure to adhere to such specifications, warnings and/ or instructions. The Buyer is also responsible to obey all applicable federal, state, and local laws and ordinances when operating his/her vehicle while using this product, and the Buyer agrees to hold SuperATV® harmless from any violation thereof.

INSTALLATION INSTRUCTIONS

**Radius Arms: for Polaris RZR[®] XP 1000
(with SuperATV Lift Kit)**

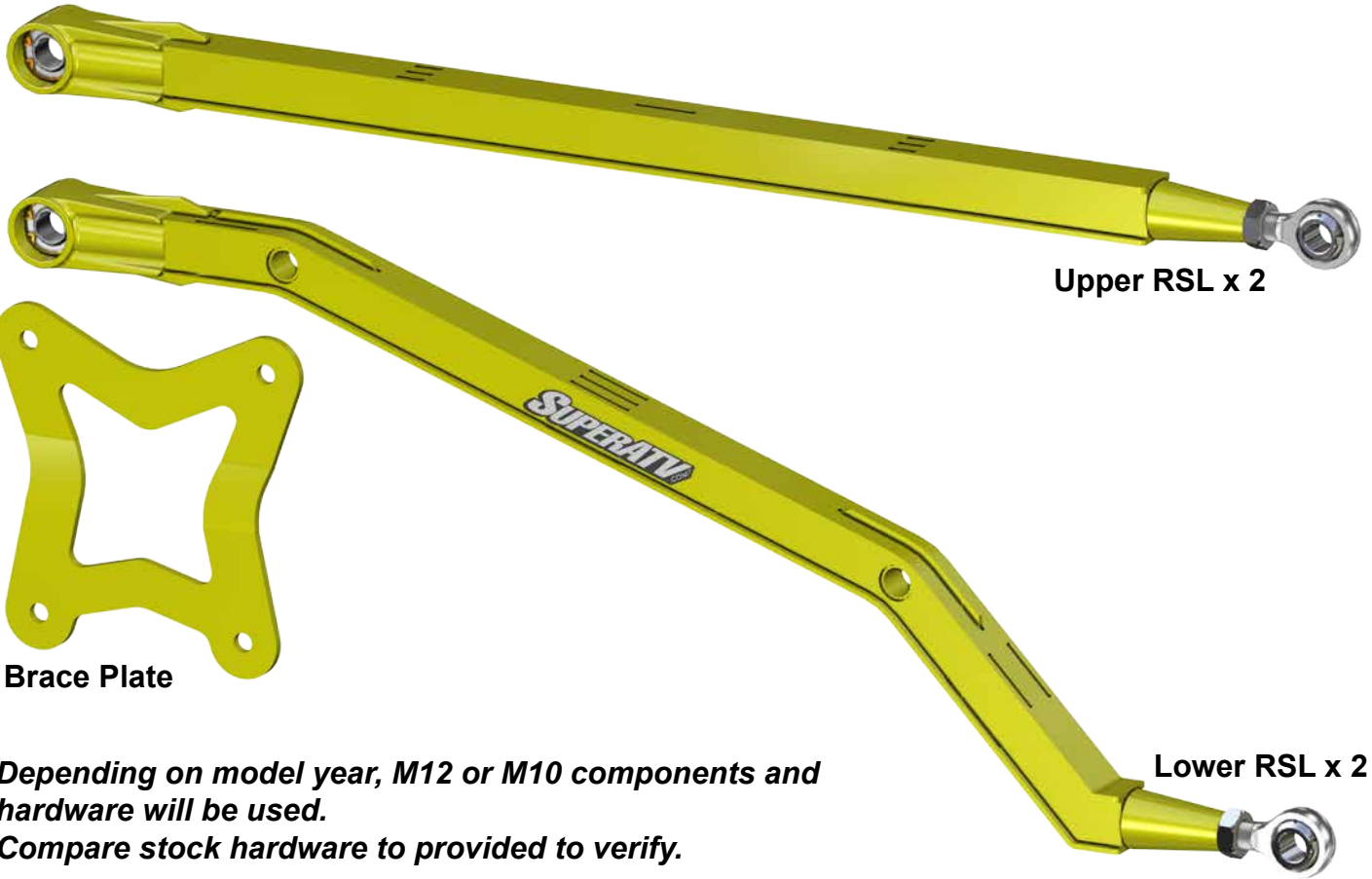

Upper RSL x 2

Lower RSL x 2

Brace Plate

- Depending on model year, M12 or M10 components and hardware will be used.
- Compare stock hardware to provided to verify.

Liability Statement

SuperATV's[®] products are designed to best fit user's ATV/UTV under stock conditions. Adding, modifying, or fabricating any factory or aftermarket parts will void any warranty provided by SuperATV[®] and is not recommended. SuperATV's[®] products could interfere with other aftermarket accessories. If user has aftermarket products on machine, contact SuperATV[®] to verify that they will work together.

Although SuperATV[®] has thousands of satisfied customers, user should be aware that installing lift kits, long travel, or suspension kits, tires, etc. will change the ride of machine and may increase maintenance and part wear. Operating any off-road machine while, or after, consuming alcohol and/or drugs increases risk of bodily harm or death. No warranty or representation is made as to this product's ability to protect user from severe injury or death. SuperATV[®] urges operators and occupants to wear a helmet and appropriate riding gear at all times.

By purchasing and installing SuperATV[®] products, user agrees that should damages occur, SuperATV[®] will not be held responsible for loss of time, use, labor fees, replacement parts, or freight charges. SuperATV[®], nor any 3rd party, will not be held responsible for any direct, indirect, incidental, special, or consequential damages that result from any product purchased from SuperATV[®]. The total liability of seller to user for all damages, losses, and causes of action, if any, shall not exceed the total purchase price paid for the product that gave rise to the claim.

SuperATV[®] will warranty only parts provided by SuperATV[®]. Any damage or problems with OEM housings, bearings, seals, or other manufacturers' products will not be covered by SuperATV[®]. SuperATV[®] parts and products are not warranted if item was not installed properly, misused, or modified.

Installing, adding, modifying, or fabricating any factory or aftermarket product to your ATV/UTV may violate certain local, state, and federal laws. Be advised that laws vary depending on town, city, county, state, etc. Use of certain products on public streets, roads, or highways may be in violation law. The Buyer is solely and exclusively legally and personally responsible for any violation of the law by the installation or use of the product. You must abide by all local, state, and federal laws, including but not limited to vehicle safety, traffic laws, and ordinances. It is your responsibility to know the laws and how they apply to you.

The Buyer is responsible to fully understand the capability and limitations of his/her vehicle according to manufacturer specifications, warnings and instructions and agrees to hold SuperATV[®] harmless from any damage resulting from failure to adhere to such specifications, warnings and/ or instructions. The Buyer is also responsible to obey all applicable federal, state, and local laws and ordinances when operating his/her vehicle while using this product, and the Buyer agrees to hold SuperATV[®] harmless from any violation thereof.

Need help with your installation?



sales@superatv.com



www.superatv.com



1-855-743-3427



8:00am - 8:00pm EST M-Th
8:00am - 7:00pm EST Friday
9:00am - 2:00pm EST Saturday

Read instructions and view illustrations before beginning.

Thank You

For Choosing

SUPERATV.COM[®]

M12 hardware

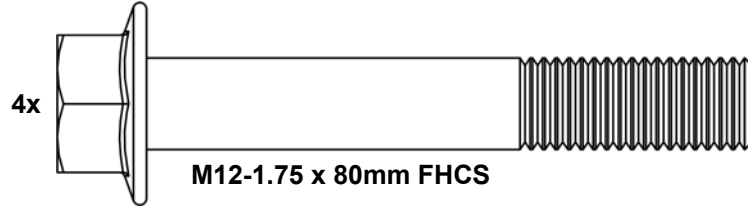

M10 hardware

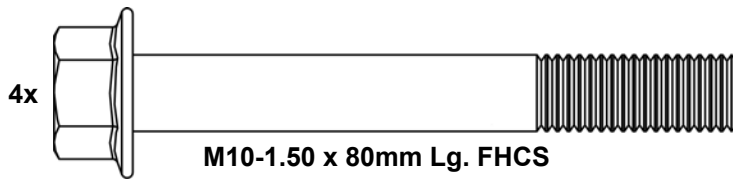

- Install Bushings into Radius Arms.

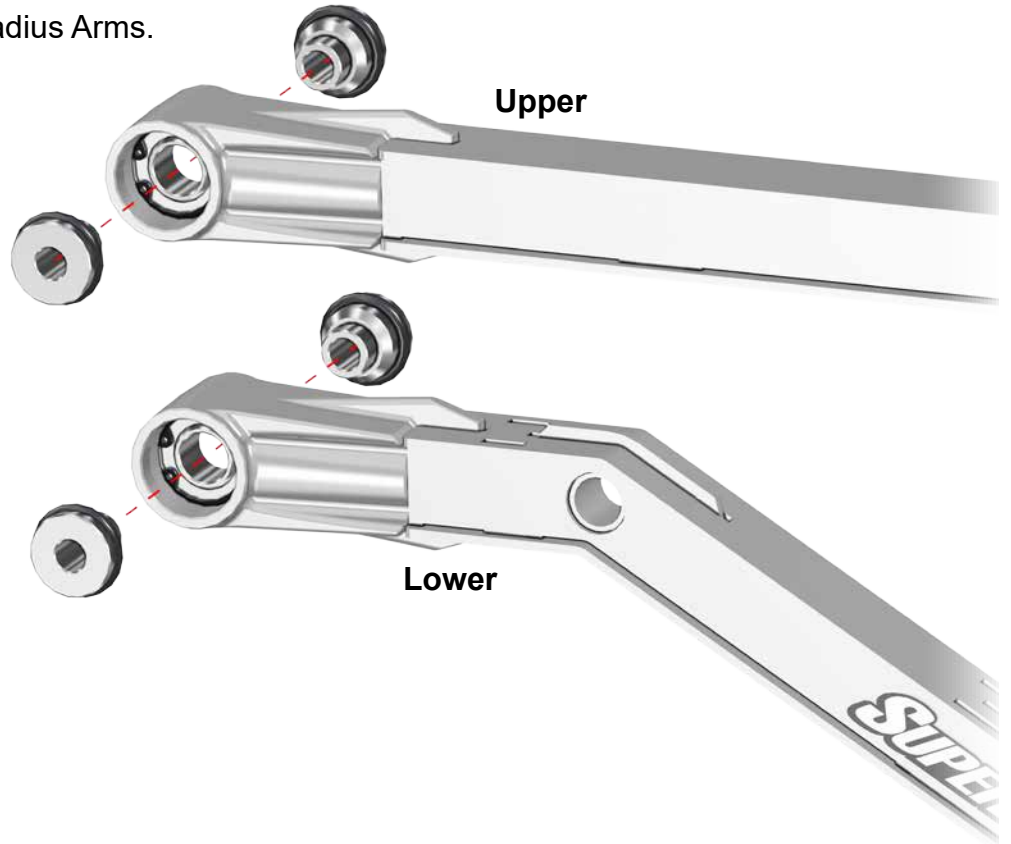

Set eye-to-eye distances to dimensions shown.

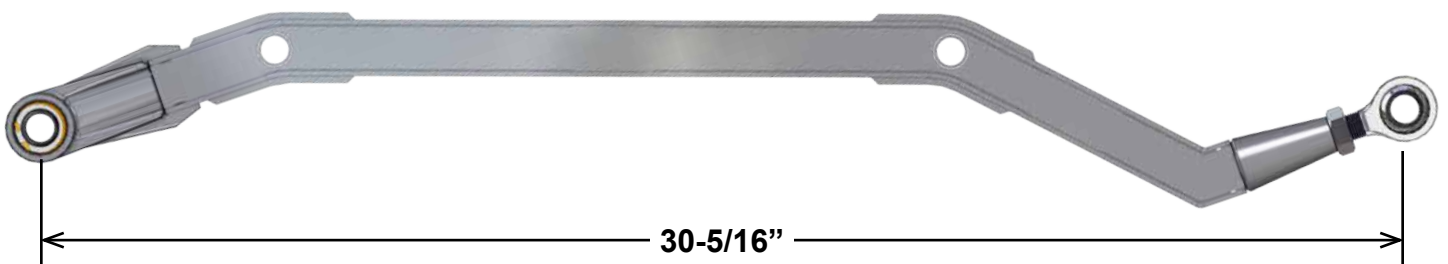

Keep all stock hardware removed from machine.



- Install new RSL's and Brace with hardware shown.

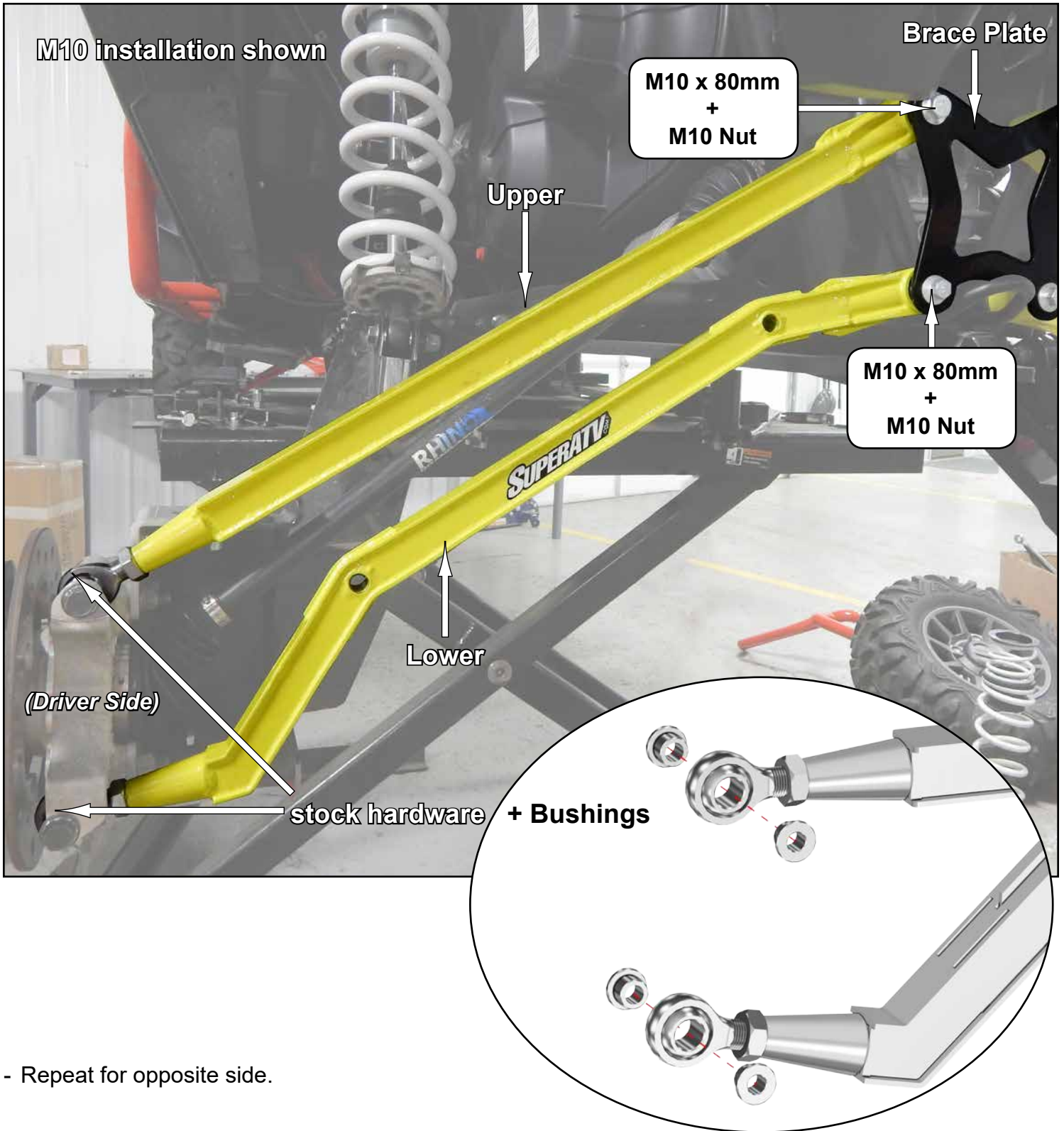

- Repeat for opposite side.

Radius Arms Adjustment:

- If Wheels and Axles do not rotate freely, equally adjust Radius Arms “out” in small increments.
- Tighten hardware completely.



CAMBER

- Tires must have equal air pressure before making adjustments.
- Adjustments to be made after all suspension components have been completely assembled.
- Tires must not be in contact with ground when making adjustments.
- Perform adjustments in small increments.

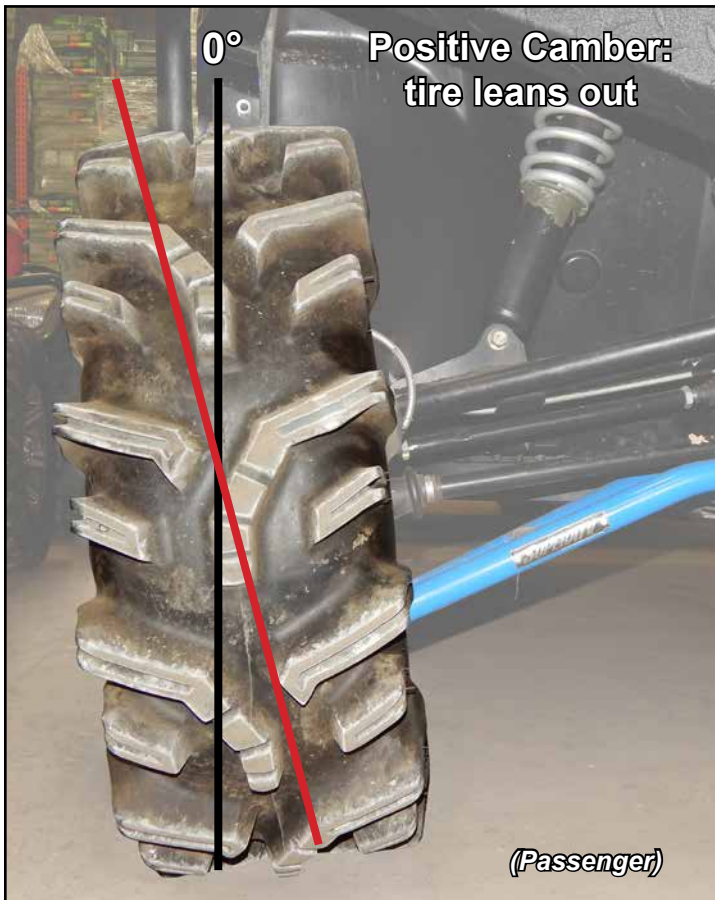

Adjusting Camber:

- Remove A-Arms from Frame and turn Pivot Blocks to adjust camber. Reinstall Arms.
- Lower machine and settle suspension components by rolling machine back and forth several feet at a time.
- Check settings and make small adjustments as needed.
- Each time an adjustment is made, machine must be rolled back and forth to settle suspension components.
- Once desired setting is achieved, tighten hardware completely. Loc-tite on Nuts is recommended.

A NEGATIVE CAMBER SETTING OF 1° to 2° IS RECOMMENDED.

LOWER:

Too much positive camber: adjust Pivot Blocks **OUT**.

Too much negative camber: adjust Pivot Blocks **IN**.

note: 2 full turns is 1°

UPPER A-ARMS:

Too much positive camber: adjust Pivot Blocks **IN**.

Too much negative camber: adjust Pivot Blocks **OUT**.

note: 2 full turns is 1°

