

Component List:

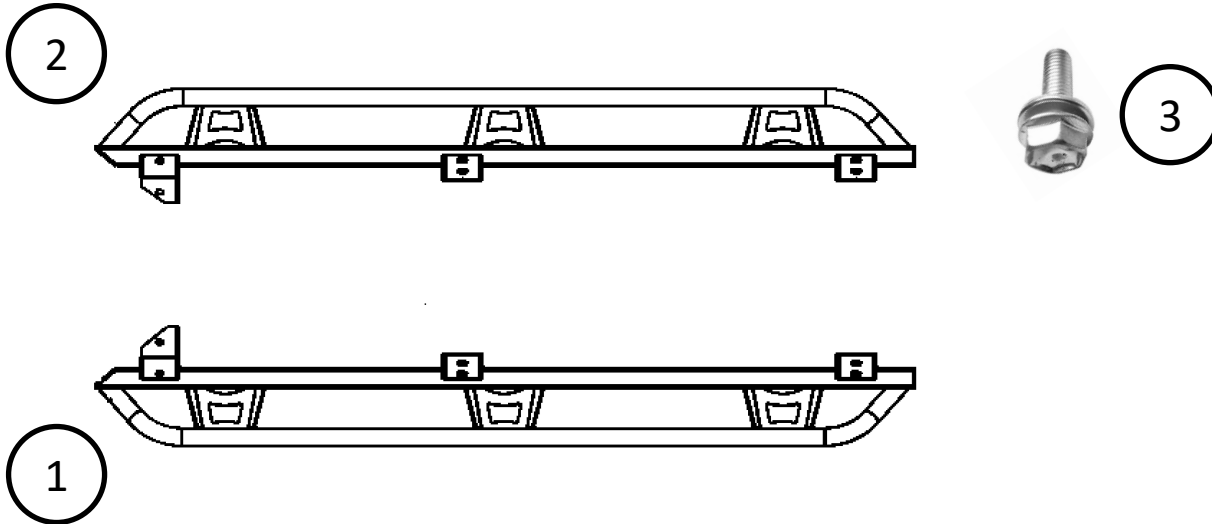

Item	QTY	Name	Description
1	1	Nerf Step	Driver Side
2	1	Nerf Step	Passenger Side
Hardware			
3	12	Flange Cap Bolt with Washer	M8-1.25x 30MM

TOOLS NEEDED FOR INSTALLATION:

13mm socket & wrench

ESTIMATED TIME FOR INSTALLATION:

.5-1 Hour

Hardware Torque Specifications & Installer Responsibility

The following chart provides general torque specifications and wrench sizes for commonly used SAE and Metric fasteners found in automotive accessory installations. These values serve as guidelines based on standard Grade 5 / Grade 8 (SAE) and Class 8.8 / 10.9 (Metric) hardware.

IMPORTANT:

It is the **installer's responsibility** to ensure all fasteners are tightened to the appropriate torque. **Failure to torque hardware correctly can lead to part failure, vehicle damage, or personal injury.** Always verify torque requirements in the vehicle's factory service manual when available.

Bolt Size	Torque Grade 8 / 10.9	Wrench/Socket Size (in/mm)
1/4"-20	8 ft-lbs (11 Nm)	7/16"
5/16"-18	17 ft-lbs (23 Nm)	1/2"
3/8"-16	30 ft-lbs (40 Nm)	9/16"
7/16"-14	45 ft-lbs (61 Nm)	5/8"
1/2"-13	80 ft-lbs (108 Nm)	3/4"
M6 x 1.0	7 ft-lbs (10 Nm)	10 mm
M8 x 1.25	16 ft-lbs (22 Nm)	13 mm
M10 x 1.5	35 ft-lbs (48 Nm)	17 mm
M12 x 1.75	60 ft-lbs (81 Nm)	19 mm

Inspection & Maintenance Recommendations

- After installation, **inspect all hardware after the first 100 miles** of driving.
 - Thereafter, **reinspect every 3 months** or 3,000 miles, whichever comes first.
 - Ensure all fasteners remain tight and free of corrosion or damage.
 - Re-torque as needed using the specifications in the chart above or per OEM requirements.
- Installer assumes all liability** for proper installation and continued inspection of hardware. If torque values are not properly applied and maintained, failure of the part and safety risks may result.

Installation Instructions:

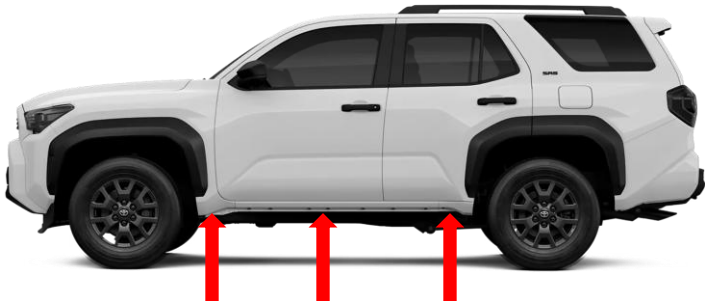

1. Starting on the driver side, identify the OEM mounting holes on the rocker panel. If any factory bolts are already installed, remove them before proceeding.



2. With the correct nerf step ready, have an assistant help position the board onto the threaded holes in the rocker panel. Secure the nerf step using M8-1.25 × 30 flange head bolt

3. Repeat the procedure on the passenger side. Torque to the required specification and confirm proper fitment of the nerf steps.