

XP[®] MOMENTUM

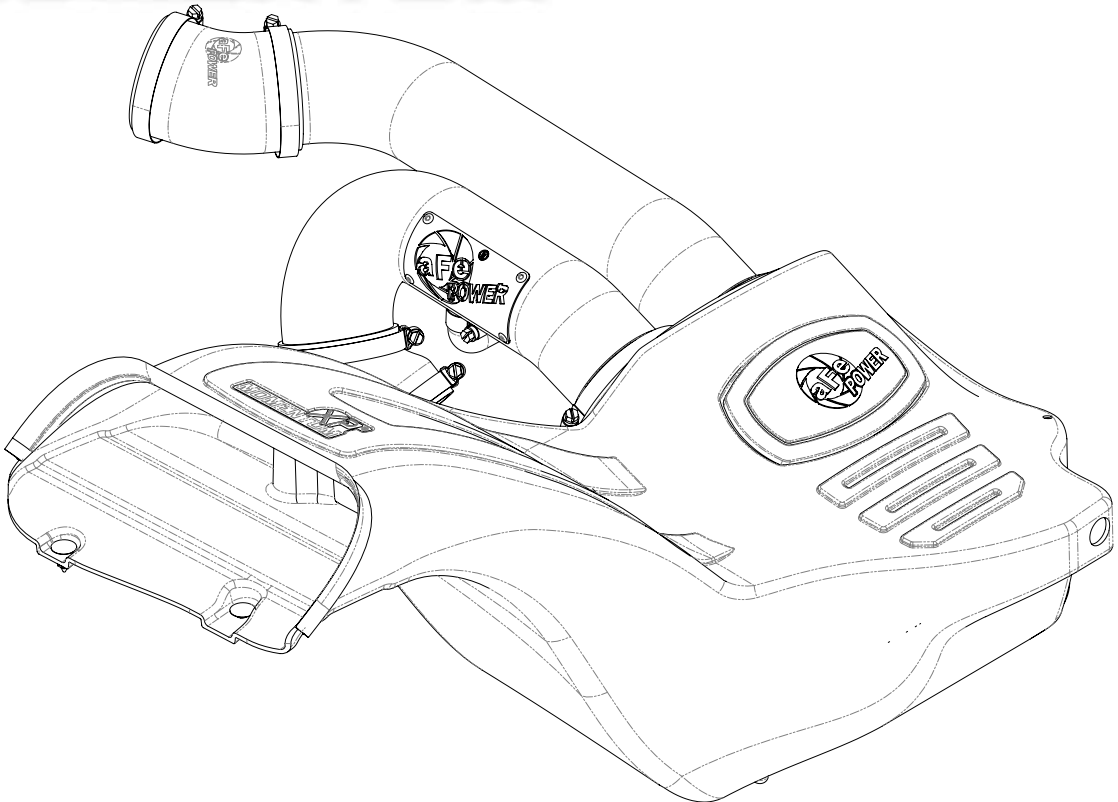

advanced FLOW engineering Momentum XP Cold Air Intake System

Instruction Manual P/N: 51-73120-B/H/L / 54-73120-B/H/L / 75-73120-B/H/L

Make: **Ford** Model: **F-150 Raptor** Year: **2017-2019** Engine: **V6-3.5L (tt) EcoBoost**

Make: **Ford** Model: **F-150** Year: **2017-2019** Engine: **V6-3.5L (tt) EcoBoost**

Make: **Ford** Model: **F-150** Year: **2018-2019** Engine: **V6-2.7L (tt) EcoBoost**



- Please read the entire instruction manual before proceeding.
- Ensure all components listed are present.
- If you are missing any of the components, call customer support at 951-493-7100.
- Ensure you have all necessary tools before proceeding.
- Do not attempt to work on your vehicle when the engine is hot.
- Disconnect the negative battery terminal before proceeding.
- Retain factory parts for future use.

Label	Qty.	Description	Part Number
A1	1	Air Filter (Pro DRY S)	21-91115
A2	1	Air Filter (Pro 5R)	24-91115
A3	1	Air Filter (Pro-GUARD 7)	72-91115
B	1	Housing	05-5030024B3
C1	1	Tube 1 of 2: Black	05-73120B1
C2	1	Tube 1 of 2: Brushed	05-73120H1
C3	1	Tube 1 of 2: Blue	05-73120L1
D1	1	Tube 2 of 2: Black	05-73120B2
D2	1	Tube 2 of 2: Brushed	05-73120H2
D3	1	Tube 2 of 2: Blue	05-73120L2
E	1	Hose, Silicone Breather: 5/8" ID	05-01444
F	1	Coupling, Silicone Elbow: (4" x 3")	05-01445
G	1	Coupling, Silicone Elbow: (3" x 3")	05-01446
H	1	Clamp, #064	03-50006
I	3	Clamp, #044	03-50019
J	2	Clamp, Mini #008	03-50077
K	2	Retainer Clip	05-01350
L	1	Seal, Trim: 7/16" (15-1/2" in.)	05-00072
M	1	Insert, Vent	05-01405
N	1	Harness, IAT Extension	05-70023

Installation will require the following tools:

7mm/8mm/nut driver or deep sockets, flat head screw driver, 13mm socket and driver, panel popper tool.

NOTE: Temp Sensor harness is only required for V6-2.7L (tt) EcoBoost Applications.

Note: Legal in California for use on race vehicles only. The use of this device on vehicles used on public streets or highways is strictly prohibited in California and others states that have adopted California emission regulations.

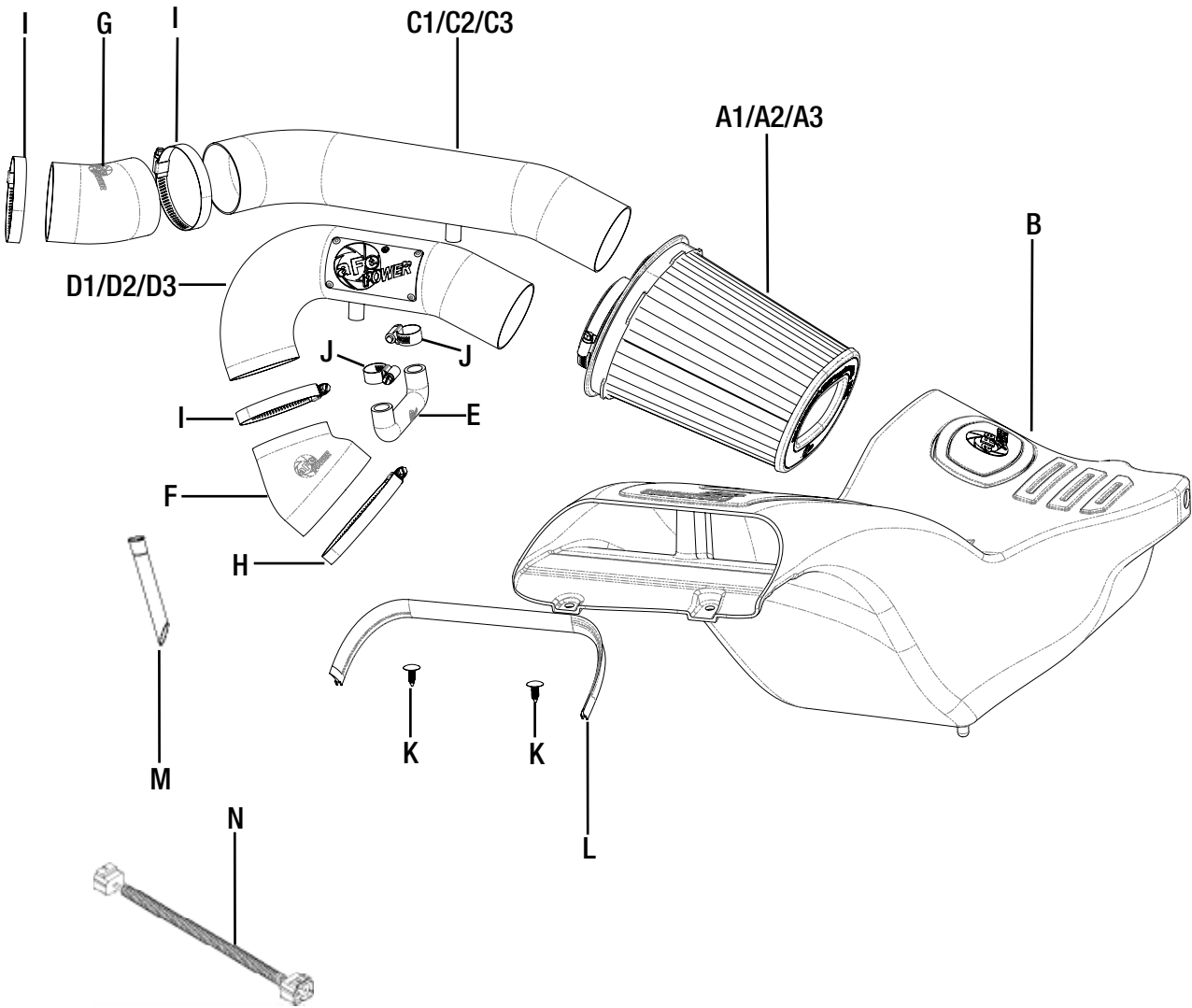



Figure A

Refer to Figure A for Steps 1-2

Step 1: Unplug temp sensor harness (1) from the back side of the intake tube. Unclip the coolant line from the intake tube.

Step 2: Loosen the clamps (2) on the intake tubes. Unclip the top of the air box (3) and remove the tube, air filter and top of the air box from the vehicle.



Refer to Figure B for Steps 3-5

Step 3: Unclip the wire from the back of the air box.

Step 4: Remove the wastegate actuator from the housing.

Step 5: Remove the screw (4) and the two plastic rivets (5) securing the housing, then pull the factory air box out of the truck.

Vent insert installation:

REMOVAL



Figure C

Refer to Figure C for Step 6

(These procedures should be done with the inlet tubes installed on the engine. It is shown off the vehicle for better illustration.)

Step 6: Locate the o.e. plastic tube feeding the driver's side turbo inlet.



Figure D

Refer to Figure I for Step 7

Step 7: Locate the valve cover vent tube that feeds into driver's side turbo inlet. It is not necessary to remove the engine cover.



Figure E

Refer to Figure E for Step 8

Step 8: Note the release clip on the vent tube connectors. Apply pressure against the exposed tail and pull vent fitting off of the turbo inlet tube. It is not necessary to disconnect at the valve cover end. There is a sensor and wire harness on this vent tube. Do not damage or remove these components.



Refer to Figure F for Step 9

Step 9: Insert vent fitting with slash cut facing turbo inlet. It should not be a loose fit. It is direction dependent and must not rotate once installed.

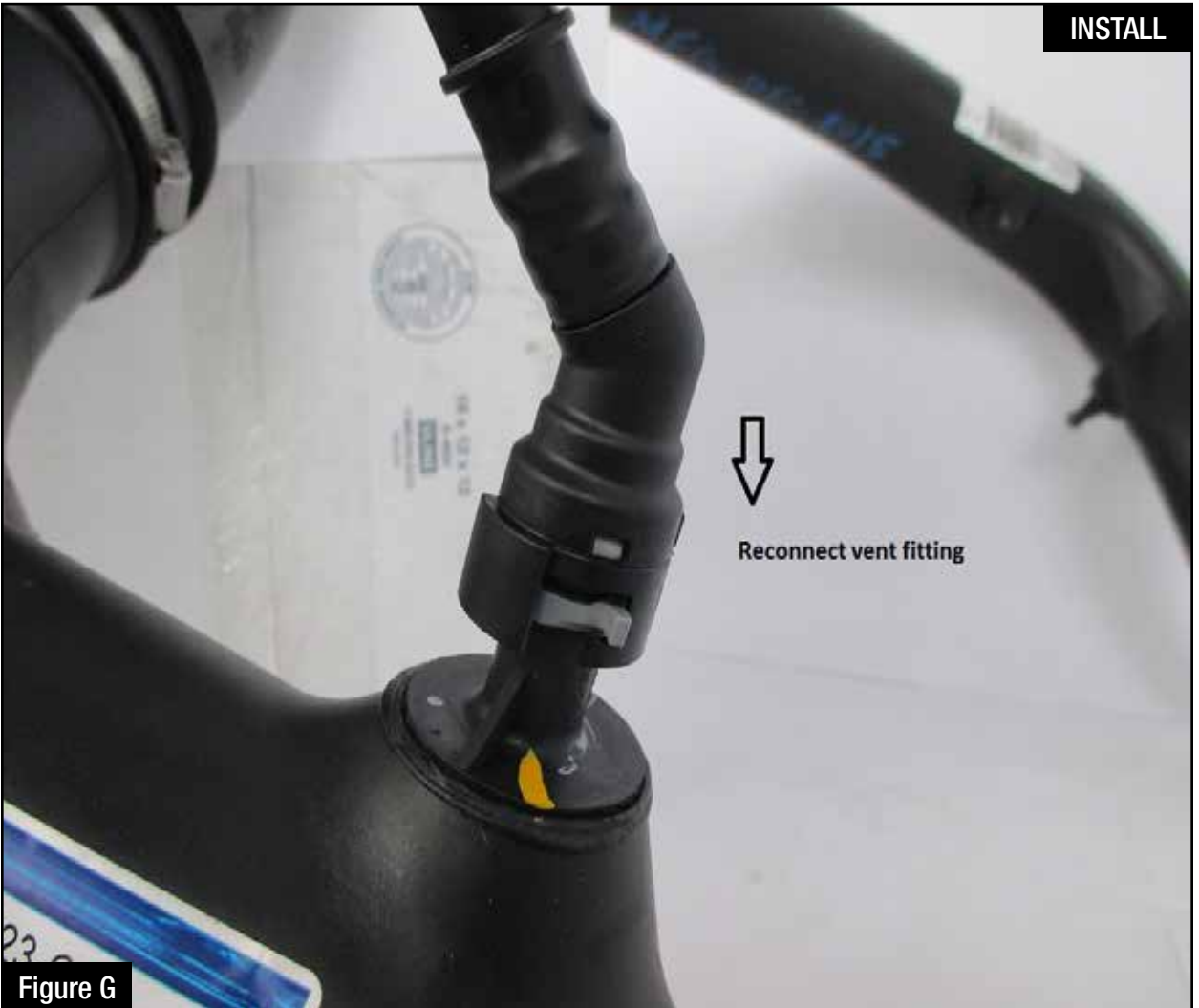

Refer to Figure G for Steps 10-11

Step 10: Reconnect the vent fitting. It will snap over without having to release the plastic clip. Pull up slightly to confirm installation.

Step 11: Installation is complete. Any codes can be cleared with a code reader or by disconnecting the battery. You will lose any radio presets with battery disconnection.

If removal of the vent insert is required, it can be pulled out with internal snap ring pliers.



Figure H

Refer to Figure H for Steps 12-13

Step 12: Transfer the grommet (6) from the factory air box to the aFe air box.

Step 13: Install the furnished seal trim (7) on the top edge of the aFe housing.

Optional: Drill two small holes in the top of the housing for the wastegate accutator wire harness to clip into. There are two drill points marking these locations and the hole size is 1/4". (8) This will allow you to mount the wastegate actuator wire to the air box, however, it will require you to relocate the push clips on the factory wire.



Figure I

Refer to Figure I for Steps 14-17

Step 14: Install the aFe housing into the truck by pushing it into the factory mounting grommets.

Step 15: Re-install the factory screw (9) removed in Step 5, inside the aFe housing.

Step 16: Secure the housing with the two furnished plastic rivets (10).

Step 17: Reconnect the wastegate accutator to the bracket on the back side of the housing. (11)



Figure J

Refer to Figure J for Step 18

Step 18: Slide aFe filter inside the housing and push it in until it locks.



Figure K

Refer to Figure K for Steps 19-20

Step 19: Install the couplers and their respective clamps onto the two intake tubes as shown in Figure K. Do not tighten clamps yet.

Step 20: Transfer the temperature sensor from the factory intake tube to the new aFe intake tube.

NOTE: V6-2.7L (tt) EcoBoost only use the provided sensor harness extension.



Figure L

Refer to Figure L for Steps 21-24

- Step 21: Install the tube 05-73120B2/H2/L2 into the air filter and then line it up with its coupler. Do not tighten the clamps at this time.
- Step 22: Install the small clamps onto the supplied silicone breather hose and then install the hose on the bottom of the intake tube 05-73120B2/H2/L2 as shown in Figure L.
- Step 23: Position the two small clamps so that they will be accessible after both intake tubes are installed.
- Step 24: Reconnect the temp sensor harness.

**Figure M****Refer to Figure M for Steps 25-28**

Step 25: Install tube 05-73120B1/H1/L1 into the filter flange.

Step 26: Position the other end of the tube on top of the coupler and rotate the coupler so that it is parallel to the intake tube.

Step 27: Tighten the lower clamp that is around the factory intake tube and then install the 05-73120B1/H1/L1 into the coupler.

Step 28: Slip the breather hose over the fitting on the front intake tube.

**Figure N****Refer to Figure N for Step 29**

Step 26: Locate the two plastic push clips for the wastegate actuator harness. Cut the tape securing these to the wire. Place the push clip in the drilled holes on the housing. Hold the wire in place along side these push clips and retape the push clips in the appropriate locations on the wire (12).



Figure 0

Refer to Figure 0 for Step 30

Step 30: Make sure all clamps and screws are tight. Remove plastic film from aFe window. Your installation is now complete.

NOTE: Check all bolts, clamps, and connectors after 200 miles.

Page left blank intentionally



Page left blank intentionally

Page left blank intentionally



Pro DRY S Air Filter



P/N: 21-91115

Pro 5R Air Filter



P/N: 24-91115

Pro-GUARD 7 Air Filter



P/N: 72-91115

Pre-Filter



P/N: 28-10283

Pro DRY S Restore Kit



P/N: 90-59999

Blue Squeeze Restore Kit



P/N: 90-50501

Gold Squeeze Restore Kit



P/N: 90-50500

SCORCHER GT Module



P/N: 77-43023

Intercooler w/ Tube



P/N: 46-20292-B

Turbo Downpipes



P/N: 48-43020-HC (Street)
48-43020-HN (Race)

Exhaust System



P/N: 49-43045-B (Blk. Tips)
49-43045-P (Pol. Tips)

To purchase any of the items above, view airflow charts, dyno graphs, photos, and video; please go to aFepower.com.

Warranty

General Terms:

- aFe warrants their products to be free from manufacturer's defects due to workmanship and material.
- This warranty applies only to the original purchaser of the product and is nontransferable.
- Proof of purchase of the aFe product is required for all warranty claims.
- Warranty is valid provided aFe instructions for installation and/or cleaning were properly followed.
- Proper maintenance with regular inspections of product is required to insure warranty coverage.
- Damage due to improper installation, abuse, unauthorized repair or alteration is not warranted.
- Incidental or consequential damages or cost, including installation and removal of part, incurred due to failure of aFe product is not covered under this warranty.
- All warranty is limited to the repair and/or replacement of the aFe part. To request Return Goods Authorization ("RGA"), email RGA@afepower.com or call (951)493-7100. Upon receipt of the RGA, you must return the product to the address provided in the RGA, freight prepaid and accompanied with a dated proof of purchase and the RGA. Upon receipt of the defective product and upon verification of proof of purchase, aFe will either repair or replace the defective product within a reasonable time, not to exceed thirty days.

Product Category	P/N Prefix	Warranty duration
Direct OE Replacement Filters	10, 11, 30, 31, 71, 73	Life of the vehicle
Racing Filters	18	1 year
Universal	21, 24, 72	2 years
Air Intake Systems	50, 51, 54, 55, 75	2 years
Exhaust Systems	49	2 years
Intercoolers & Intercooler Tubes	46-2	2 years
Intake Manifolds	46-1	2 years
Differential Cover	46-7	Life of the vehicle
Exhaust Manifolds	46	2 years
Throttle Body Spacers	46-3	2 years
Fluid Filters	44	90 days
Pre-Filters	28	2 years
Heavy Duty OE Replacement	70	2 years
PowerSports OE Replacement	81, 87	2 years
PowerSports Intake Systems	85	2 years

No other warranty expressed or implied applies nor is any person or advanced FLOW engineering authorized to assume any other warranty. Some States do not allow the exclusion or limitation of incidental or consequential damages or do not allow limitations on how long an implied warranty lasts, so the above limitations or exclusions may not apply to you. This warranty gives you specific legal rights, and you may also have other rights which vary from State to State.

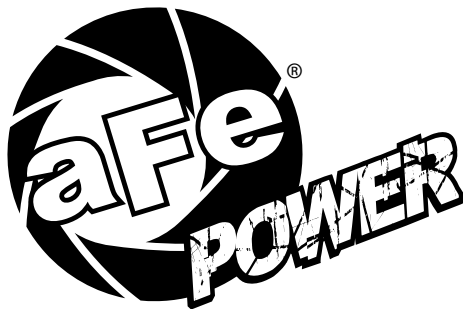

advanced FLOW engineering, inc.
252 Granite Street Corona, CA 92879
TEL: 951.493.7100 • TECH: 951.493.7134
E-Mail: Tech@aFepower.com