



baja designs®
THE SCIENTISTS OF LIGHTING

Ford Bronco (21+) Squadron and Dual S2 Steel Bumper Fog light kit Instructions



185 Bosstick Boulevard • San Marcos • CA • 92069

Phone 760-560-2252 X3 • Fax 760-560-0383

info@bajadesigns.com • www.bajadesigns.com



baja designs[®]
THE SCIENTISTS OF LIGHTING

LIMITED LIFETIME WARRANTY

Baja Designs proudly offers a LIFETIME WARRANTY against manufacturer's defect on all the products that we manufacture.

These are comprehensive warranties; other than the exclusions below – you're covered. If your LED or HID bulb burns out, you're covered. Additionally, cutting off our connector or changing your lenses does not automatically void your warranty.

Exclusions:

Installation errors, abuse, misuse or crash damage. You must be the original owner of the product and can supply proof of purchase.

Baja Designs manufactures its own products as well as resells products manufactured by others. Baja Designs makes no express or implied warranties on products not manufactured by Baja Designs including without limitation any warranties or merchantability and fitness for a purpose. We will, however, pass on all warranties made by the manufacturer, who has sole responsibility for performing such warranties.

Baja Designs will pay the freight if your product is less than 90 days old, otherwise defective products must be returned to Baja Designs, Inc., freight prepaid. At our option, we will repair or replace items in question and return them at no charge. If the identical product is no longer available, we will replace with a similar product of equal value. Baja Designs Inc. will not be responsible for any indirect or consequential damages in connection with defective merchandise.

Items purchased through a Baja Designs authorized dealer must be returned through the dealer. Only available on LED auxiliary lights and product must be in sellable condition at MSRP. Product that has been damaged in any way after the original purchase date will be excluded from this guarantee.

Indemnification:

Buyer hereby acknowledges off-roading, racing and driving at night are dangerous activities and that the products and/or supplies purchased from Baja Designs are used in an inherently dangerous activity that may endanger life and limb; and in no event shall the seller, or seller's heirs and assigns, be held liable for consequential damages, nor shall seller's liability on any claim for damages arising out of or connected with the sale, delivery, or use of purchased products and/or supplies exceed the purchase price of the products and/or supplies

Ford Bronco 21+ Steel Bumper Fog Pocket kit Instructions

Tools Required

- 10mm and 1/2" Wrench (battery tools)
- Pliers
- Electrical tape
- T40 Torx bit
- 3/4 Drill (non-upfitter models)
- 9/16", 7/16", and 10mm Sockets
- 9/16" wrench
- 4mm Allen Wrench

1. To begin, place the vehicle in park, turn off and disconnect the negative battery terminal (1/2" wrench).
2. Locate the Squadron and S2 lights with the brackets and parts bags. Hand thread together the 9/16" hex head hardware through the brackets. With the 4mm Allen wrench, assemble the brackets to the lights as shown. Repeat for all six lights.
3. With the provided 7/16" hex nuts and washers, attach the driver side light mounting brackets to the driver side fog light facia bracket over the pressed in studs (not shown). Take note the orientation of the mounting brackets. They differ from passenger to driver side.

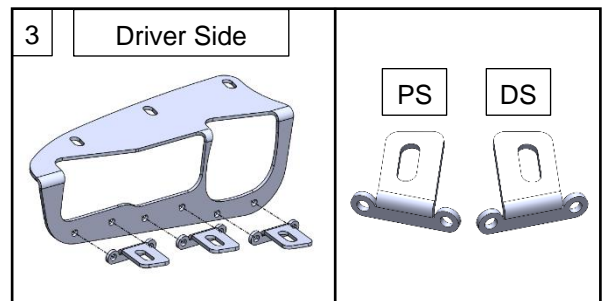
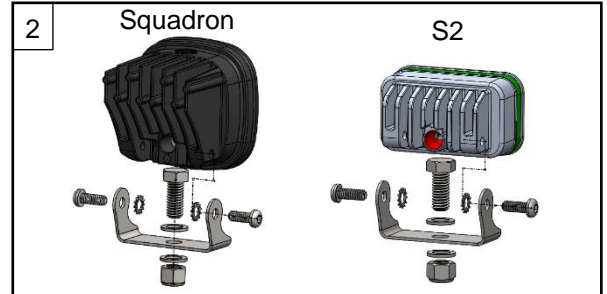

(Note: do not use power tools on pressed in hardware)

4. Now with the 9/16" wrench and socket, mount each light to the Baja designs fog light bracket assembly with the 9/16" hex head bracket hardware (hardware not shown). The Squadron mounts in the single opening, while the s2s mount in the double opening. (Driver side shown) Repeat for the other side.

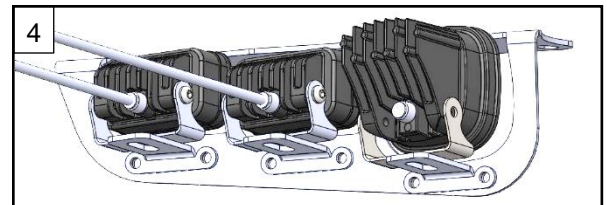

5. Locate the three bolts inside the top surface of either fog light opening in the bumper. Use the T40 bit to remove the bolts, mount the fog light assembly, replace the bolts and tighten. (Driver side shown). Repeat for the other side.
6. Included are two small splitter wiring harnesses and two large splitter harnesses. Reference the wiring diagram to the right and begin wiring from the driver side fog light. The large splitters will need the upstream connector placed on the driver side. The wires can pass through the split from the bumper to the skid plate. Tie all wires away from hot, sharp, and/or rotating components.

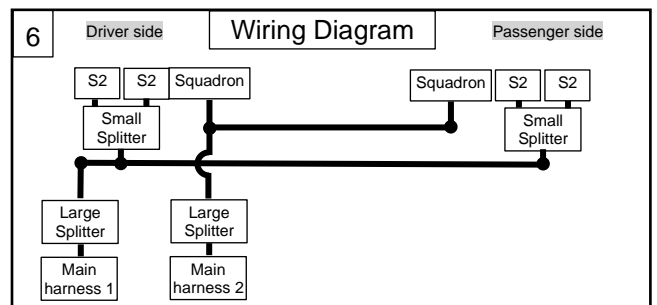

10. The main harness (upfitter or toggle switch) will need to be unraveled. Route the light lead of the harness along the driver side inner fender away from any hot, sharp, and/or rotating components. Continue routing the harness down to the driver side fog light behind the headlight. Connect each main harness lead to the large splitters. Remove the slack and tie the harness as needed, pulling up into the engine compartment. Any extra harness length can be tied up and placed into the inner driver side fender.

11. If you purchased the Upfitter switch version:

- Locate the bundle of upfitter wires in the back driver side corner taped to the large wiring harness. Pull the tape off to access the wires.
- Reference the table to choose a switch locations. We recommend AUX3 – AUX6.
- Using the pliers, clasp the splice connector of the upfitter splice harness over the desired wire/circuit. Repeat for second harness. Wrap the tape back over the remaining wires. Make sure all wires are isolated and add electrical tape as needed.
- Mount the black ring terminal of the splice harnesses to the common ground on the driver side firewall using a 10mm socket wrench.
- Reattach battery ground (-).

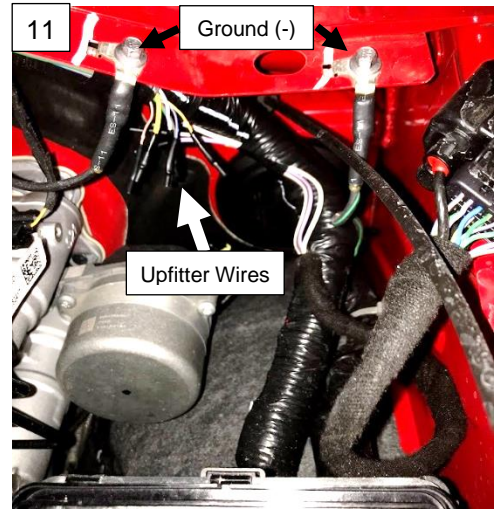

Power Distribution Box	Wire Color	Wire Size	Fuse
AUX 1	Yellow	1.5 mm ²	30A
AUX 2	Green/Brown	1.5 mm ²	15A
AUX 3	Violet/Green	0.75 mm ²	10A
AUX 4	Brown	0.75 mm ²	10A
AUX 5	Blue/Orange	0.75 mm ²	10A
AUX 6	Yellow/Orange	0.75 mm ²	10A

12. If you purchased the stand-alone toggle switch version:

- Locate the firewall passthrough grommet on the right side of the brake booster. In the cab, this will be located next to the footrest. Push grommet into engine compartment from the cab.
- There are two easy options for switch locations on the dash in the locations arrowed under the headlight controls.
- Gently pull dash panel away until unclipped. Locate the two circled indentations on the back of the dash below the headlight controls. These are the two suggested switch mounting locations.
- Snap a photo of the switch wiring for reference later. Remove the switch terminals from the switches. Remove the tape around the wires on either side of the passthrough grommet.
- Choose the desired dash locations for the switches. Drill 3/4" hole.
- Thread the wires through the hole in the passthrough grommet, reattach switch terminals, and mount switch. Tape around the wires of the grommet. Install dash panel.
- Mount the (+) and (-) ring terminals of the harness to the corresponding battery terminals starting with the (+) red lead.
- Reattach battery ground (-)

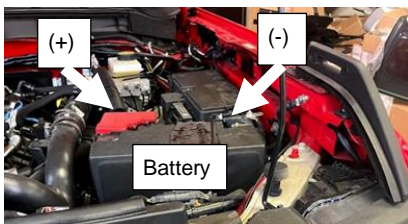
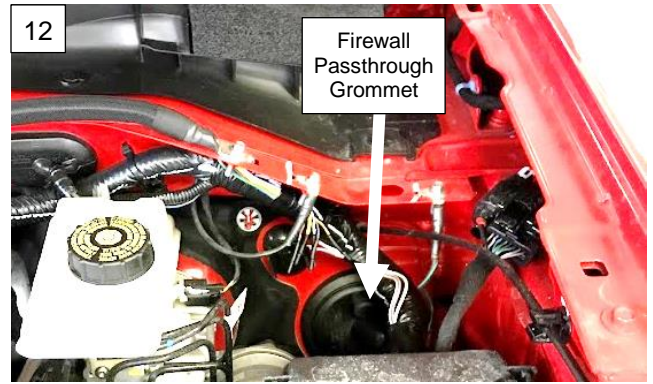

Tie all wires away from sharp, hot, and/or rotating components.

Re-torque all the fasteners after 100 miles.

Your install is now complete! Thank you for choosing Baja Designs.

